

MVL-MF1224M-5MPE

2/3" 12 mm 5MP FA Lens

MF-E series FA Lens are optimized for machine vision light sources and sensors, with high resolution, excellent image uniformity, high transmittance and good stability. Featured with fixed focal length, manual aperture and compact size, it is suitable for machine vision industry applications.



Key Features

- High resolution and consistency of image clarity.
- Lower distortion and higher relative illumination rate.
- Achromatic optical system design and better imaging performance with color camera.
- Excellent performance at high and low temperature.
- Good optical performance at ultra-short working distance.

Distortion

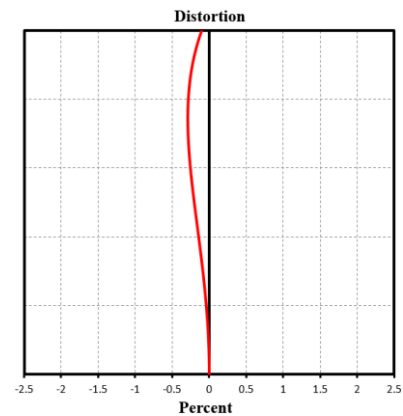

MTF

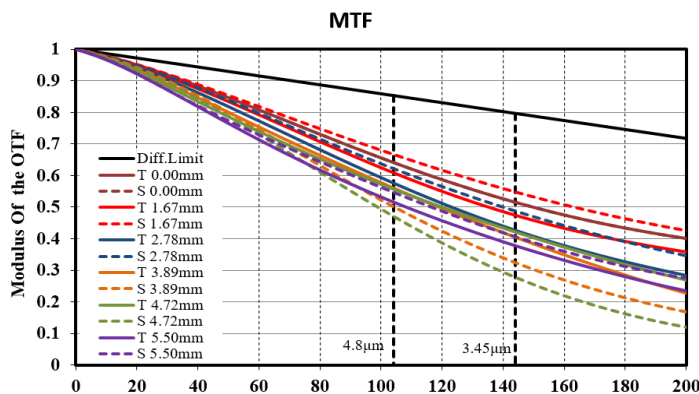

Relative Illumination

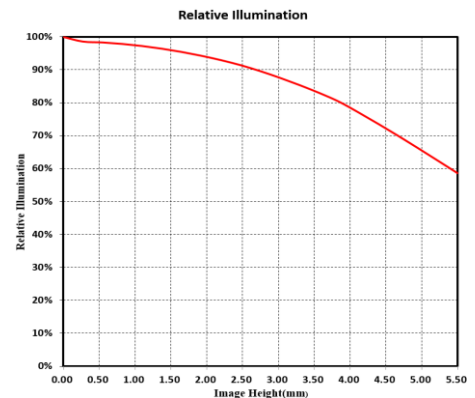

Note: The above curves are the simulate results based on F2.4, $\beta = -0.039$, WD=300 mm.

Specification

Parameter	Model	MVL-MF1224M-5MPE
		Fixed focal length, Manual iris, 5MP, FA Lens
Performance		
Focal length		12 mm
F-number		F2.4 to F16
Image size		Ø11 mm (2/3")
TV distortion		-0.15%
Minimum object distance		0.15 m
Field of view		D (11.1 mm): 48.9° H (8.45 mm): 38.3° V (7.07 mm): 32.4°
Mechanical		
Iris control		Manual
Focus control		Manual
Filter thread		M27 × 0.5
Mount		C-mount
Flange focal length		17.526 mm
Dimension		Ø29 mm × 36 mm to 37.5 mm (Ø1.1" × 1.4" to 1.5")
Weight		71.6 g (0.2 lb.)
Temperature		-10 °C to 50 °C (14 °F to 122 °F)
General		
Certification		RoHS 2.0

Dimension

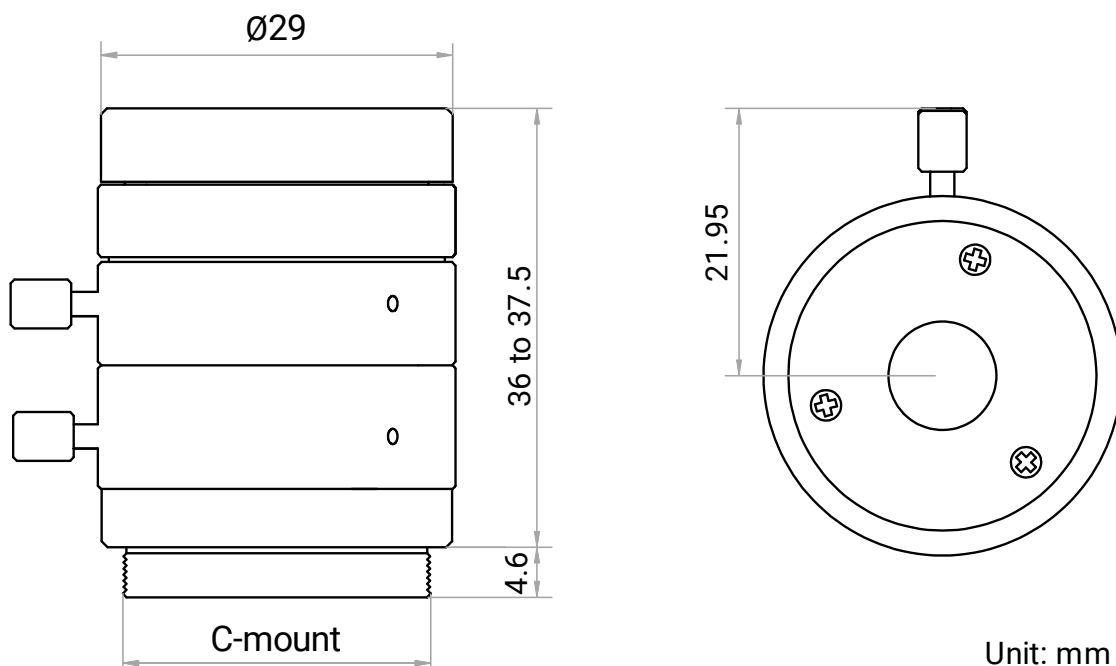

Unit: mm

Field of View

Ring thickness (mm)	Working distance (mm)		Magnification	Field of view (mm)					
				2/3"		1/1.8"		1/2"	
				H (8.45mm)	V (7.07mm)	H (7.38mm)	V (4.92mm)	H (6.22mm)	V (4.67mm)
10	Near	2.2	-0.900	9.2	7.7	8.0	5.3	6.7	5.0
	Far	4.2	-0.778	10.7	8.9	9.3	6.1	7.8	5.8
5	Near	12.5	-0.503	16.6	13.8	14.3	9.5	12.0	9.0
	Far	20.0	-0.381	21.9	18.3	18.9	12.5	15.8	11.8
2	Near	33.8	-0.265	31.7	26.4	27.2	18.0	22.8	17.0
	Far	72.2	-0.143	58.8	49.1	50.5	33.5	42.2	31.6
1	Near	53.1	-0.186	45.3	37.8	38.9	25.8	32.5	24.3
	Far	174.6	-0.065	131.1	109.6	113.0	75.2	94.8	71.1
0		150	-0.074	113.8	95.1	99.3	66.1	83.7	62.7
		200	-0.057	149.1	124.6	130.2	86.6	109.6	82.2
		250	-0.046	184.4	154.2	161.0	107.2	135.6	101.7
		300	-0.039	219.7	183.7	191.8	127.7	161.6	121.2
		350	-0.033	255.0	213.3	222.7	148.3	187.6	140.7
		400	-0.029	290.3	242.8	253.5	168.8	213.6	160.2
		450	-0.026	325.6	272.4	284.3	189.4	239.5	179.7
		500	-0.024	360.9	301.9	315.1	209.9	265.5	199.2
		550	-0.021	396.2	331.5	346.0	230.5	291.5	218.7
		600	-0.020	431.5	361.0	376.8	251.0	317.5	238.2
		650	-0.018	466.8	390.6	407.6	271.6	343.5	257.7
		700	-0.017	502.1	420.1	438.5	292.2	369.4	277.2
		800	-0.015	572.6	479.2	500.1	333.3	421.4	316.2
		900	-0.013	643.2	538.3	561.8	374.4	473.4	355.3
	1000	-0.012	713.7	597.3	623.7	415.6	525.4	394.3	