

MVL-KF0814M-12MPE

1.1" 8mm 12MP FA LENS

KF-E series FA Lens are optimized for machine vision light sources and sensor, with high resolution, excellent image quality, high transmittance and good stability. Featured with fixed focal length, manual aperture and compact size, it is suitable for machine vision industry applications and ideal for industrial cameras.



Key Features

- Ultra high resolution and consistency of image clarity
- Lower distortion
- Super high image peripheral brightness ratio
- Excellent optical properties are maintained at different object distances

Distortion

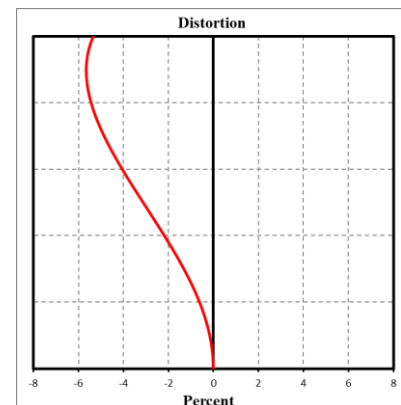

MTF

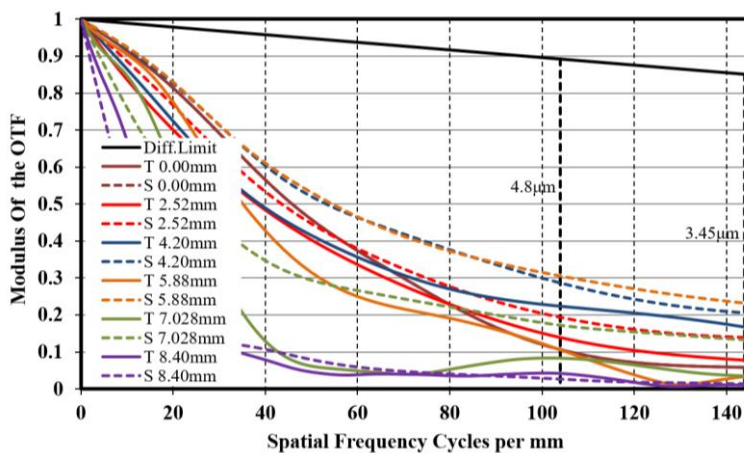

Relative Illumination

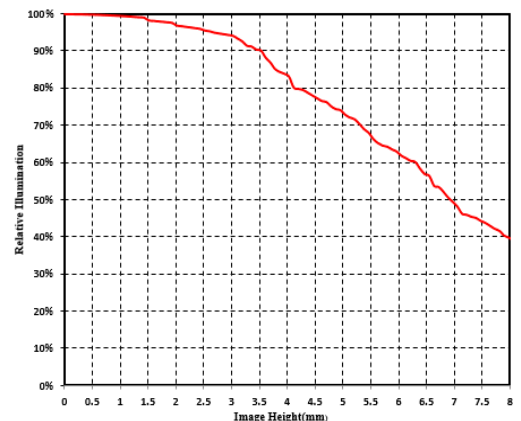

Note: The above curves are the simulate results based on F1.4, $\beta=-0.016$, WD=500 mm.



Specification

Parameter	Model	MVL- KF0814M -12MPE
		Fixed focal length, Manual iris, 12MP, FA lens
Performance		
Focal length		8 mm
F-number		F1.4 to F16
Image size		Ø17.6 mm (1.1")
Distortion		5.5%
Minimum object distance		0.1 m
Field of view		D (17.52 mm): 98.4° H (14.14 mm): 84.8° V (10.35 mm): 68°
Mechanical		
Iris control		Manual
Focus control		Manual
Filter thread		M58 × 0.75
Mount		C-mount
Flange back length		17.526 mm
Dimension		Ø60 mm × 77.8 mm (Ø2.4" x 3.1")
Weight		371 g (0.8 lb.)
Temperature		-10 °C to 50 °C (14 °F to 122 °F)
General		
Certification		RoHS 2.0

Dimension

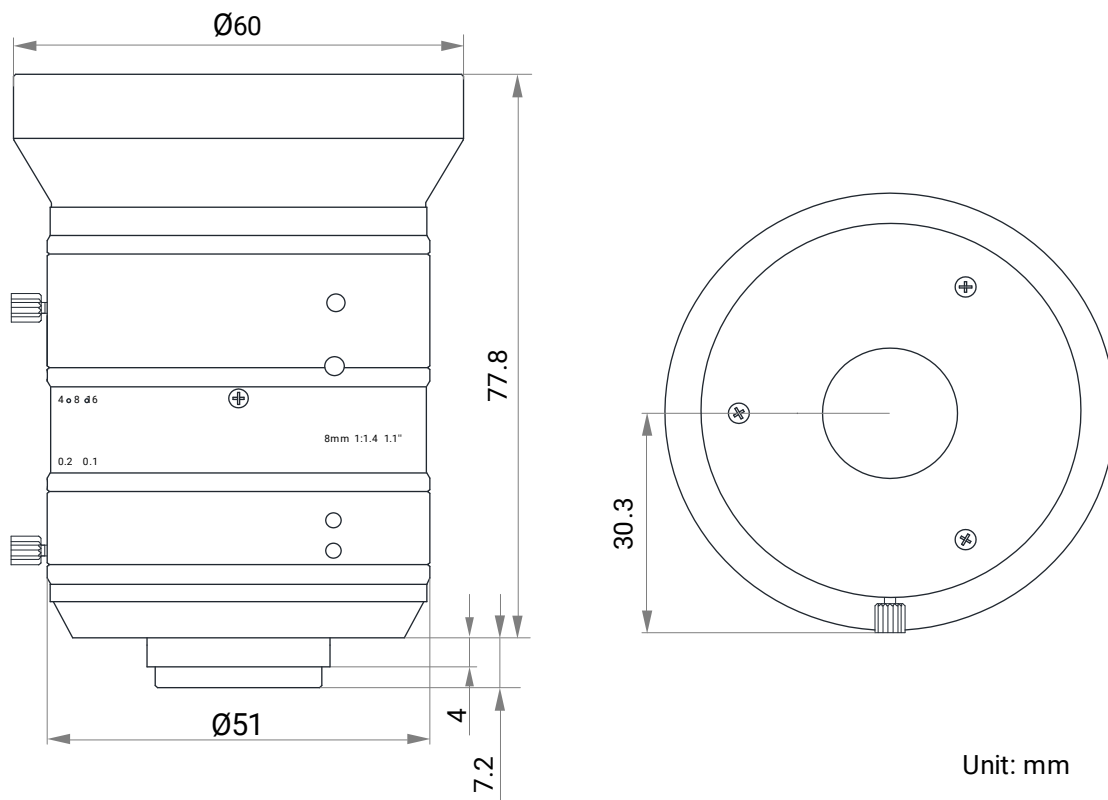

Field of View

Extension (mm)	Working Distance(mm)		Magnification	Field of View(mm)					
				1.1" (14.14mm×10.35mm)		1" (12.45mm×9.83mm)		2/3" (8.45mm×7.07mm)	
				H	V	H	V	H	V
1	near	16.32	-0.193	73.00	53.47	66.00	50.53	46.00	34.50
	far	35.02	-0.133	106.00	77.63	96.00	73.50	66.00	49.50
0		100	-0.064	220.08	161.09	193.93	153.12	131.62	110.12
		150	-0.046	305.62	223.71	269.10	212.47	182.64	152.81
		200	-0.036	391.47	286.54	344.68	272.15	233.94	195.74
		250	-0.030	477.70	349.66	420.61	332.09	285.47	238.85
		300	-0.025	563.35	412.35	496.02	391.63	336.65	281.67
		350	-0.022	649.52	475.42	571.89	451.54	388.15	324.76
		400	-0.019	736.46	539.06	648.44	511.98	440.10	368.23
		450	-0.017	822.09	601.74	723.84	571.51	491.28	411.05
		500	-0.016	912.26	667.74	803.23	634.19	545.16	456.13
		550	-0.014	995.77	728.87	876.76	692.25	595.07	497.89
		600	-0.013	1087.69	796.15	957.69	756.15	650.00	543.85
		650	-0.012	1168.60	855.37	1028.93	812.40	698.35	584.30
		700	-0.011	1262.50	924.11	1111.61	877.68	754.46	631.25
		800	-0.010	1428.28	1045.45	1257.58	992.93	853.54	714.14
	900	-0.009	1606.82	1176.14	1414.77	1117.05	960.23	803.41	
	1000	-0.008	1789.87	1310.13	1575.95	1244.30	1069.62	894.94	

HIKROBOT

Hangzhou Hikrobot Co. Ltd.
en.hikrobotics.com

© Hangzhou Hikrobot Co., Ltd. All Rights Reserved.
Hangzhou Hikrobot does not tolerate any infringement. Any organization or individual may not imitate or reproduce in whole or in part of the content. The data herein is based on Hikrobot's internal evaluation. Actual data may vary depending on specific configuration and operating condition. The information herein is subject to change without notice. All the content has been checked conscientiously. Nevertheless, Hikrobot shall not be liable to damages resulting from errors, inconsistencies or omissions.