

MVL-HF4028M-6MPE

1/1.8" 40mm 6MP FA LENS

HF-E series FA Lens are optimized for machine vision light sources and sensor, with high resolution, excellent image quality, high transmittance and good stability. Featured with fixed focal length, manual aperture and compact size, it is suitable for machine vision industry applications and ideal for industrial cameras.



Key Features

- High image clarity and contrast ratio
- Ultra-low distortion and higher relative illumination rate
- Good optical performance at ultra-short working distance
- Compact design, convenient for device integration

Distortion

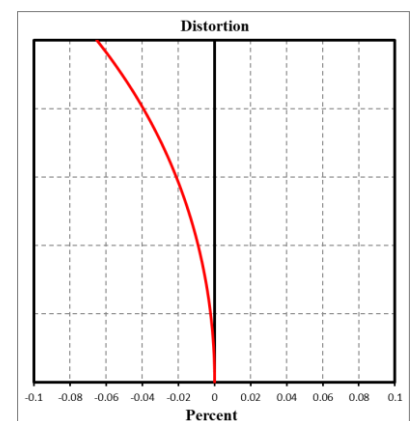

MTF

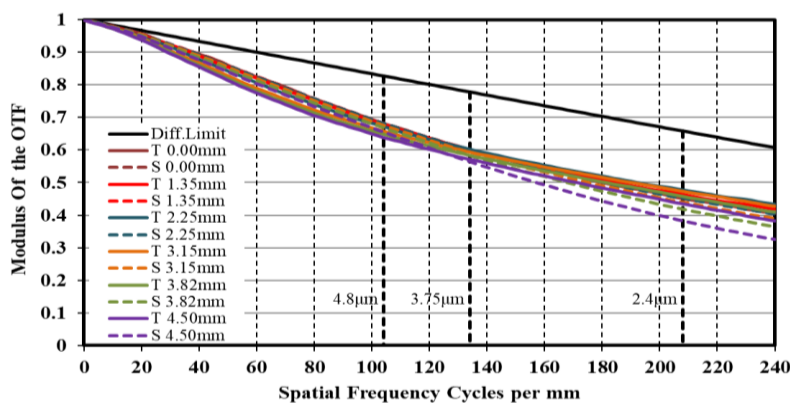

Relative Illumination

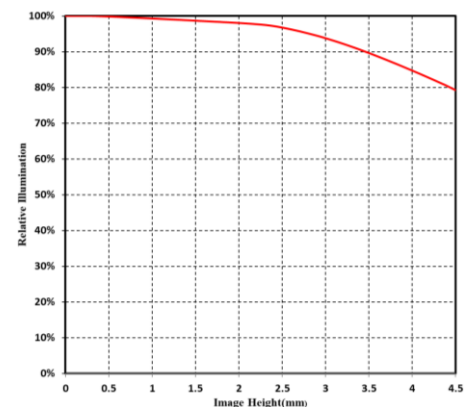

Note: The above curves are the simulate results based on F2.8, $\beta=-0.0806$, WD=500 mm.



Specification

Parameter	Model	MVL-HF4028M-6MPE
	Fixed focal length, Manual iris, 6MP, FA Lens	
Performance		
Focal length	40 mm	
F-number	F2.8 to F16	
Image size	Ø9 mm (1/1.8")	
Distortion	-0.024%	
Minimum object distance	0.25 m	
Field of view	D (8.96 mm): 12.78° H (7.38 mm): 10.53° V (4.92 mm): 7.04°	
Mechanical		
Iris control	Manual	
Focus control	Manual	
Filter thread	M27 × P0.5	
Mount	C-mount	
Flange back length	17.526 mm	
Dimension	Ø33 mm × 41.5 mm (Ø1.3" x 1.6")	
Weight	67.1 g (0.1 lb.)	
Temperature	-10 °C to 50 °C (14 °F to 122 °F)	
General		
Certification	RoHS 2.0	

Dimension

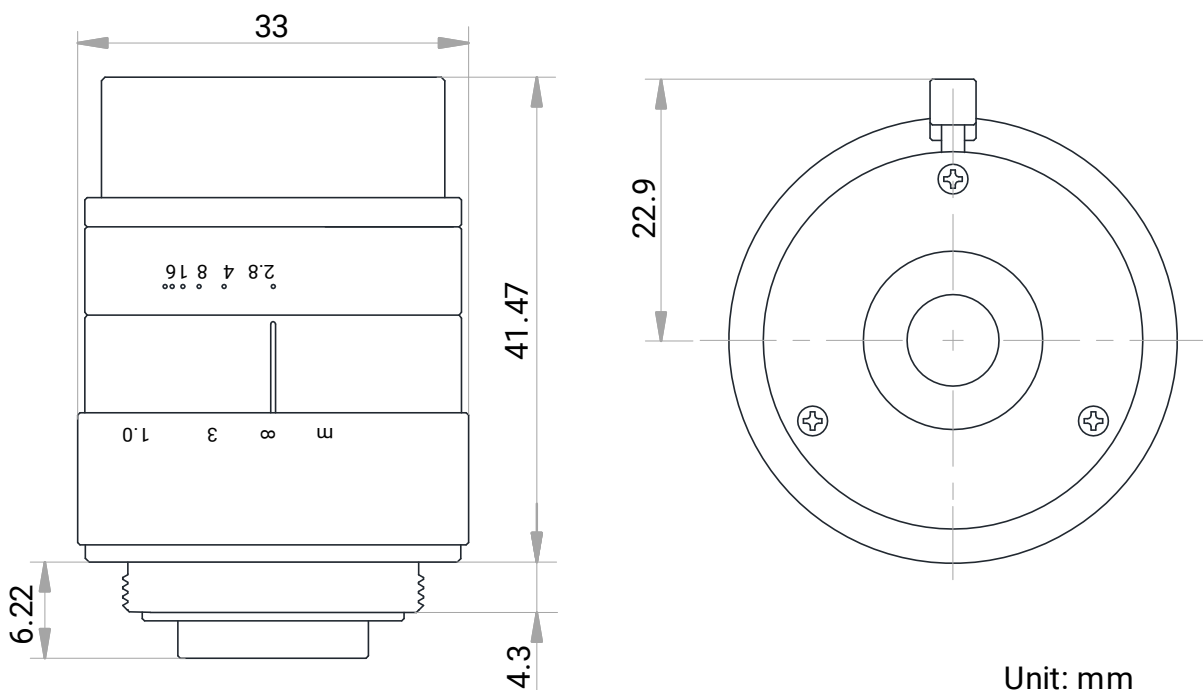

Field of View

Extension (mm)	Working Distance (mm)		Magnification	Field of View (mm)			
				1/1.8"		1/2"	
				H(7.38mm)	H(4.92mm)	H(6.22mm)	V(4.67mm)
20	near	78	-0.569	13.00	8.66	10.95	8.22
	far	148	-0.310	23.90	15.90	20.12	15.09
10	near	98	-0.431	17.17	11.43	14.46	10.85
	far	226	-0.207	35.73	23.79	30.09	22.58
5	near	138	-0.293	25.28	16.84	21.30	15.98
	far	460	-0.104	71.21	47.48	60.02	45.07
2	near	187	-0.209	35.34	23.54	29.77	22.35
	far	1162	-0.041	177.84	118.68	149.97	112.66
1	near	214	-0.181	40.76	27.16	34.35	25.78
	far	2337	-0.021	356.09	237.72	300.34	225.67
0		250	-0.153	48.15	32.08	40.57	30.45
		300	-0.129	57.16	38.09	48.16	36.15
		350	-0.112	65.97	43.96	55.59	41.73
		400	-0.099	74.63	49.74	62.89	47.21
		450	-0.089	83.18	55.43	70.09	52.62
		500	-0.081	91.63	61.07	77.22	57.97
		550	-0.074	100.00	66.66	84.28	63.27
		600	-0.068	108.31	72.20	91.28	68.53
		650	-0.063	116.56	77.71	98.24	73.76
		700	-0.059	124.77	83.18	105.16	78.96
		800	-0.052	141.06	94.05	118.90	89.27
		900	-0.047	157.22	104.84	132.52	99.51
	1000	-0.043	173.27	115.55	146.06	109.69	

HIKROBOT

Hangzhou Hikrobot Co. Ltd.
en.hikrobotics.com

© Hangzhou Hikrobot Co., Ltd. All Rights Reserved.

Hangzhou Hikrobot does not tolerate any infringement. Any organization or individual may not imitate or reproduce in whole or in part of the content. The data herein is based on Hikrobot's internal evaluation. Actual data may vary depending on specific configuration and operating condition. The information herein is subject to change without notice. All the content has been checked conscientiously. Nevertheless, Hikrobot shall not be liable to damages resulting from errors, inconsistencies or omissions.