

MVL-HF3524M-10MP

1/1.8" 35mm 10MP FA LENS

HF-P series FA Lens are optimized for machine vision light sources and sensor, with high resolution, excellent image quality, high transmittance and good stability. Featured with fixed focal length, manual aperture and compact size, it is suitable for machine vision industry applications and ideal for industrial cameras.



Key Features

- Ultra high resolution and consistency of image clarity
- Bigger aperture, lower distortion and higher relative illumination rate
- Achromatic optical system design, Better imaging performance with color camera
- Excellent vibration resistance performance, optical axis shifting within pixel level
- Good stability at high and low temperature
- Multilayer and broadband coating design, compatible with visible and near-infrared applications

Distortion

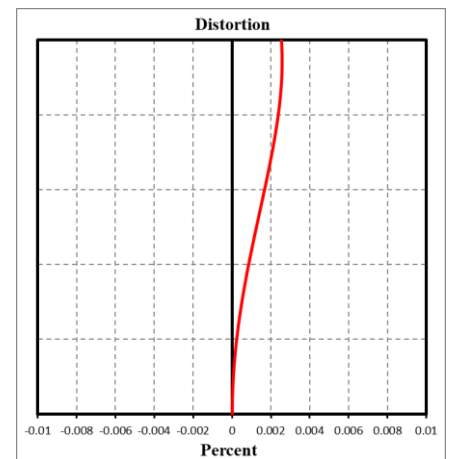

MTF

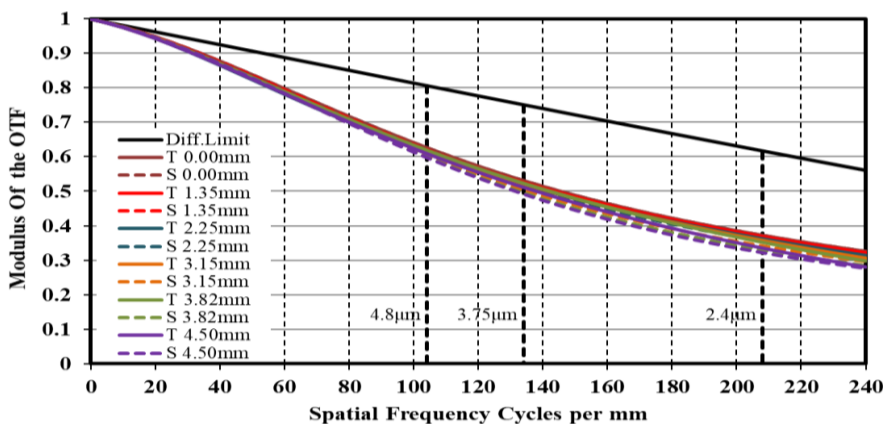

Relative Illumination

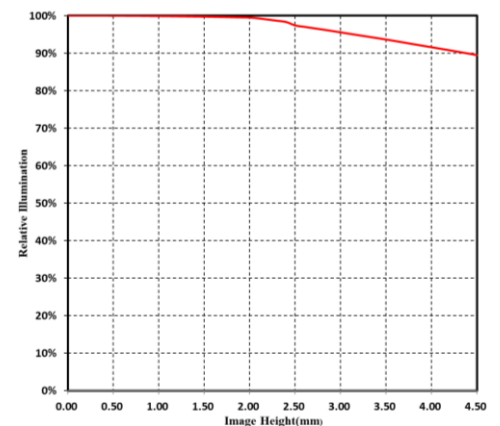

Note: The above curves are the simulate results based on F2.4, $\beta = -0.074$, WD=500 mm.

Specification

Parameter	Model	MVL-HF3524M-10MP
		Fixed focal length, Manual iris, 10MP, FA Lens
Performance		
Focal length		35 mm
F-number		F2.4 to F16
Image size		Ø9 mm (1/1.8")
Distortion		0.01%
Minimum object distance		0.15 m
Field of view		D (8.96 mm): 13.47° H (7.38 mm): 11.03° V (4.92 mm): 7.34°
Mechanical		
Iris control		Manual
Focus control		Manual
Filter thread		M27 × 0.5
Mount		C-mount
Flange back length		17.526 mm
Dimension		Ø29 mm × 51.68 mm (Ø1.1" x 2.0")
Weight		85.1 g (0.2 lb.)
Temperature		-10°C to 50°C (14 °F to 122 °F)
General		
Certification		RoHS 2.0

Dimension

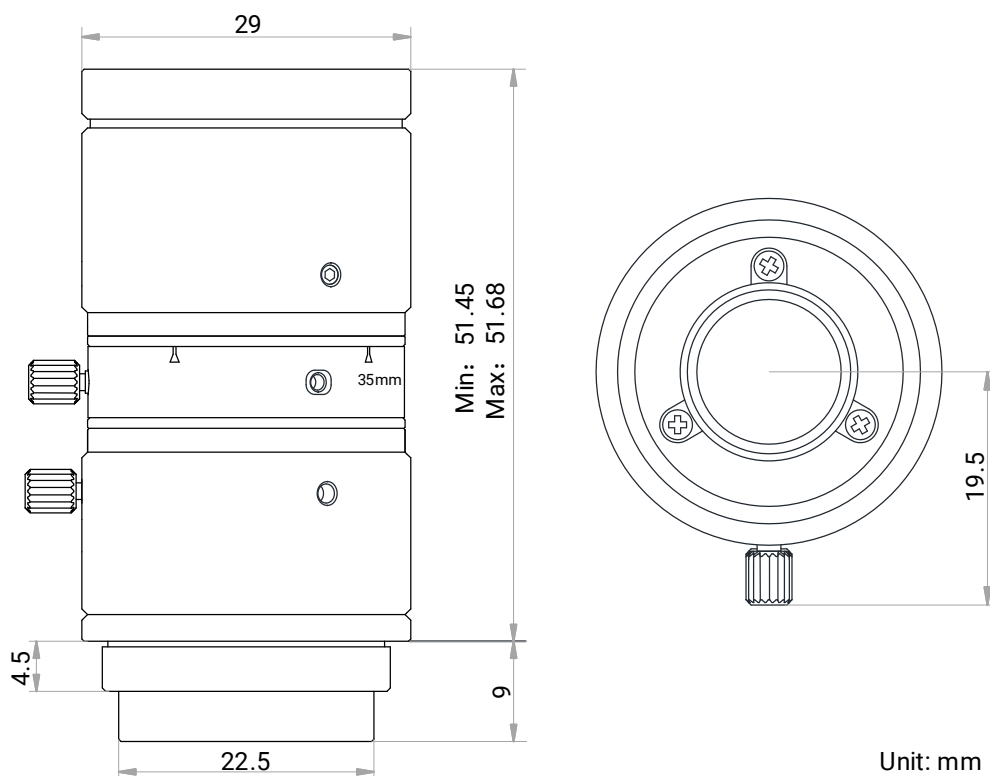

Unit: mm

Field of View

Extension (mm)	Working Distance (mm)		Magnification	Field of View (mm)			
				1/1.8"		1/2"	
				H(7.38mm)	V(4.92mm)	H(6.22mm)	V(4.67mm)
10	near	86.5	-0.565	13.08	8.72	11.02	8.27
	far	146	-0.288	25.65	17.10	21.62	16.23
5	near	107.4	-0.422	17.50	11.67	14.75	11.07
	far	266	-0.145	51.00	34.00	42.98	32.27
2	near	128.5	-0.336	21.97	14.65	18.52	13.90
	far	625	-0.058	126.70	84.48	106.79	80.19
1	near	138.2	-0.308	24.02	16.01	20.25	15.20
	far	1200	-0.030	248.04	165.40	209.08	157.00
0		150	-0.279	26.51	17.67	22.34	16.77
		200	-0.199	37.07	24.71	31.24	23.45
		250	-0.155	47.62	31.74	40.13	30.12
		300	-0.127	58.16	38.77	49.02	36.80
		350	-0.107	68.71	45.81	57.91	43.48
		400	-0.093	79.26	52.83	66.80	50.15
		450	-0.082	89.81	59.87	75.69	56.83
		500	-0.074	100.35	66.90	84.58	63.50
		550	-0.067	110.87	73.92	93.45	70.16
		600	-0.061	121.44	80.96	102.35	76.85
		650	-0.056	131.98	88.00	111.24	83.53
		700	-0.052	142.52	88.00	120.12	83.53
		800	-0.045	163.58	109.07	137.87	103.52
		900	-0.040	184.70	123.15	155.68	116.90
	1000	-0.036	184.70	123.15	173.46	116.90	