

MVL-HF2524M-10MP

1/1.8" 25mm 10MP FA LENS

HF-P series FA Lens are optimized for machine vision light sources and sensor, with high resolution, excellent image quality, high transmittance and good stability. Featured with fixed focal length, manual aperture and compact size, it is suitable for machine vision industry applications and ideal for industrial cameras.



Key Features

- Ultra high resolution and consistency of image clarity
- Bigger aperture, lower distortion and higher relative illumination rate
- Achromatic optical system design, Better imaging performance with color camera
- Excellent vibration resistance performance, optical axis shifting within pixel level
- Good stability at high and low temperature
- Multilayer and broadband coating design, compatible with visible and near-infrared applications

Distortion

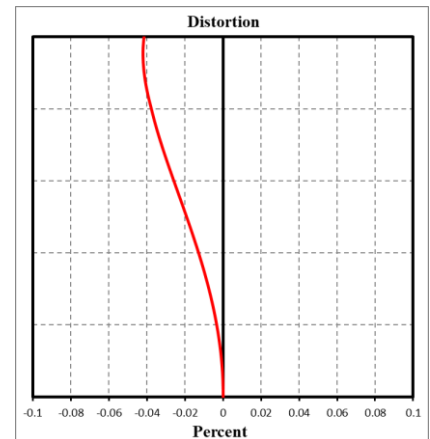

MTF

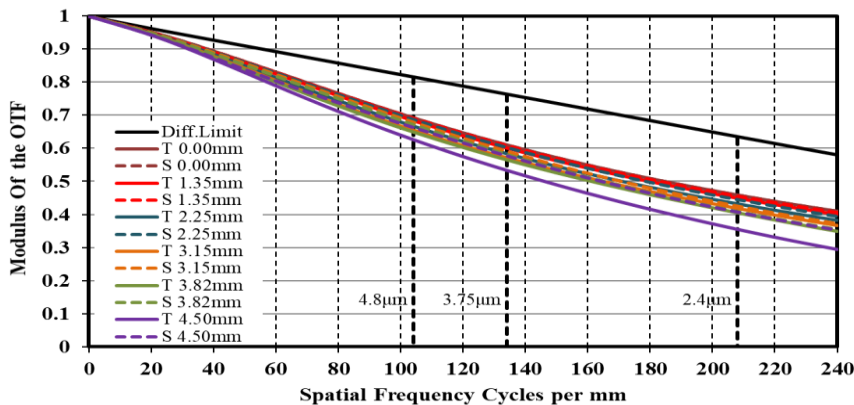

Relative Illumination

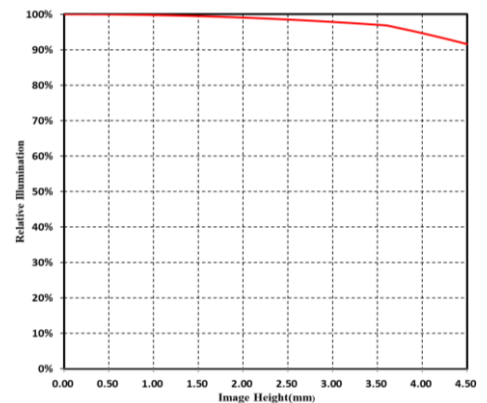

Note: The above curves are the simulate results based on F2.4, $\beta = -0.051$, WD=500 mm.

Specification

| Parameter | Model | MVL-HF2524M-10MP |
|-------------------------|-------|---|
| | | Fixed focal length, Manual iris, 10MP, FA Lens |
| Performance | | |
| Focal length | | 25 mm |
| F-number | | F2.4 to F16 |
| Image size | | Ø9 mm (1/1.8") |
| Distortion | | -0.01% |
| Minimum object distance | | 0.1 m |
| Field of view | | D (8.96 mm): 19.67° H (7.38 mm): 16.19° V (4.92 mm): 10.85° |
| Mechanical | | |
| Iris control | | Manual |
| Focus control | | Manual |
| Filter thread | | M27 × 0.5 |
| Mount | | C-mount |
| Flange back length | | 17.526 mm |
| Dimension | | Ø29 mm × 41.43 mm (Ø1.1" x 1.6") |
| Weight | | 73.8 g (0.2 lb.) |
| Temperature | | - 10°C to 50°C (14 °F to 122 °F) |
| General | | |
| Certification | | RoHS 2.0 |

Dimension

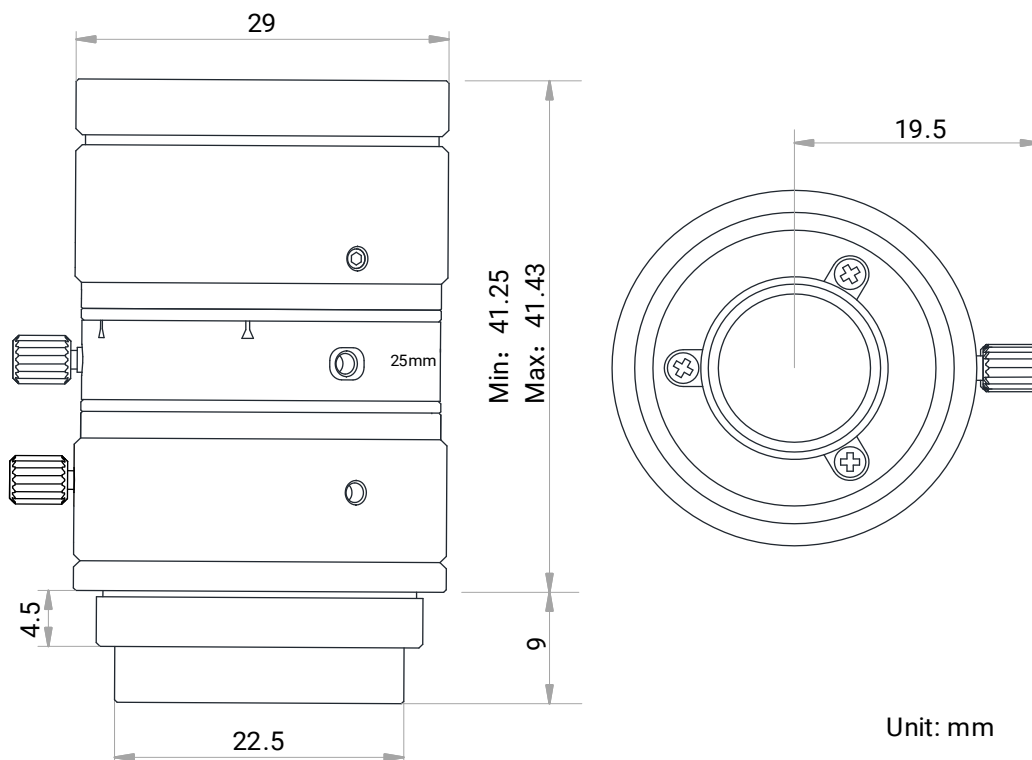

Unit: mm

Field of View

| Extension (mm) | Working Distance (mm) | | Magnification | Field of View (mm) | | | |
|----------------|-----------------------|--------|---------------|--------------------|-----------|-----------|-----------|
| | | | | 1/1.8" | | 1/2" | |
| | | | | H(7.38mm) | V(4.92mm) | H(6.22mm) | V(4.67mm) |
| 10 | near | 46.1 | -0.655 | 11.30 | 7.52 | 9.52 | 7.14 |
| | far | 65.9 | -0.409 | 18.16 | 12.08 | 15.29 | 11.47 |
| 5 | near | 62.35 | -0.470 | 15.75 | 10.49 | 13.27 | 9.96 |
| | far | 125.8 | -0.205 | 36.18 | 24.08 | 30.47 | 22.85 |
| 2 | near | 80.25 | -0.358 | 20.65 | 13.75 | 17.39 | 13.05 |
| | far | 305.5 | -0.082 | 90.09 | 60.02 | 75.91 | 56.97 |
| 1 | near | 89 | -0.321 | 23.04 | 15.35 | 19.41 | 14.57 |
| | far | 606 | -0.041 | 180.19 | 120.09 | 151.85 | 113.99 |
| 0 | | 100 | -0.284 | 26.04 | 17.35 | 21.94 | 16.47 |
| | | 150 | -0.180 | 41.04 | 27.35 | 34.58 | 25.96 |
| | | 200 | -0.132 | 56.05 | 37.35 | 47.23 | 35.45 |
| | | 250 | -0.104 | 71.04 | 47.34 | 59.86 | 44.94 |
| | | 300 | -0.086 | 86.04 | 57.34 | 72.51 | 54.43 |
| | | 350 | -0.073 | 101.03 | 67.33 | 85.14 | 63.91 |
| | | 400 | -0.064 | 116.02 | 77.33 | 97.77 | 73.40 |
| | | 450 | -0.056 | 131.01 | 87.32 | 110.41 | 82.89 |
| | | 500 | -0.051 | 146.00 | 97.32 | 123.04 | 92.37 |
| | | 550 | -0.046 | 160.99 | 107.31 | 135.68 | 101.86 |
| | | 600 | -0.042 | 175.99 | 117.31 | 148.32 | 111.35 |
| | | 650 | -0.039 | 190.96 | 127.29 | 160.94 | 120.82 |
| | | 700 | -0.036 | 205.96 | 137.30 | 173.58 | 130.32 |
| | | 800 | -0.031 | 235.92 | 157.27 | 198.84 | 149.28 |
| | 900 | -0.028 | 265.90 | 177.26 | 224.11 | 168.25 | |
| | 1000 | -0.025 | 295.93 | 197.28 | 249.42 | 187.26 | |