

# MVL-HF1224M-10MP

## 1/1.8" 12mm 10MP FA LENS

HF-P series FA Lens are optimized for machine vision light sources and sensor, with high resolution, excellent image quality, high transmittance and good stability. Featured with fixed focal length, manual aperture and compact size, it is suitable for machine vision industry applications and ideal for industrial cameras.



### Key Features

- Ultra high resolution and consistency of image clarity
- Bigger aperture, lower distortion and higher relative illumination rate
- Achromatic optical system design, Better imaging performance with color camera
- Excellent vibration resistance performance, optical axis shifting within pixel level
- Good stability at high and low temperature
- Multilayer and broadband coating design, compatible with visible and near-infrared applications

### Distortion

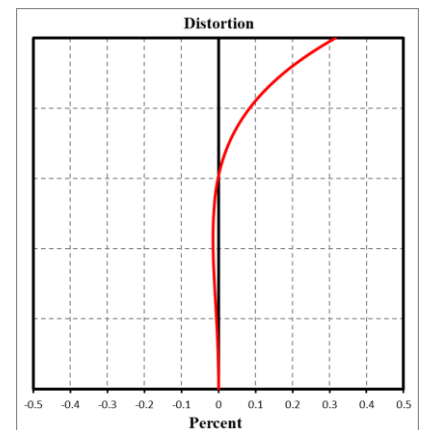

### MTF

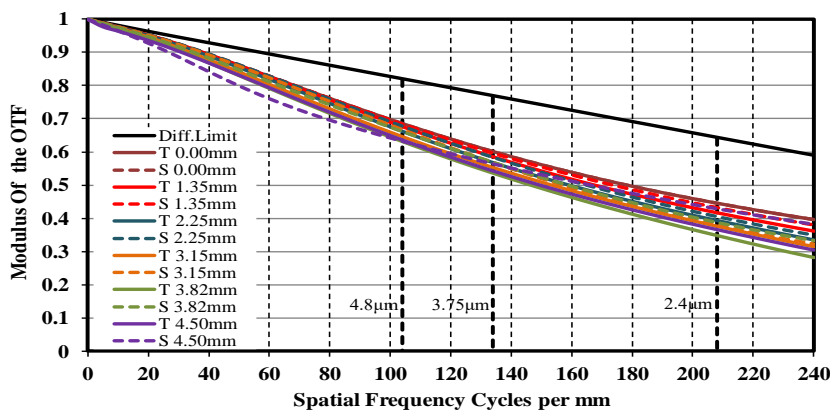

### Relative Illumination

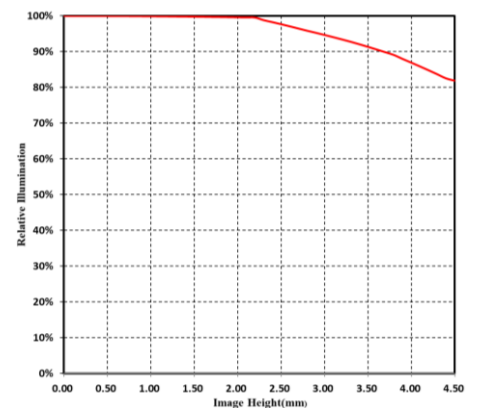

Note: The above curves are the simulate results based on F2.4,  $\beta = -0.029$ , WD=400 mm.

## Specification

Parameter	Model	MVL-HF1224M-10MP
		Fixed focal length, Manual iris, 10MP, FA Lens
<b>Performance</b>		
Focal length		12 mm
F-number		F2.4 to F16
Image size		Ø9 mm (1/1.8")
Distortion		0.15%
Minimum object distance		0.1 m
Field of view		D (8.96 mm): 40.2° H (7.38 mm): 33.6° V (4.92 mm): 22.9°
<b>Mechanical</b>		
Iris control		Manual
Focus control		Manual
Filter thread		M27 × 0.5
Mount		C-mount
Flange back length		17.526 mm
Dimension		Ø29 mm × 37 mm (Ø1.1" x 1.5")
Weight		65.9 g (0.1 lb.)
Temperature		-10°C to 50°C (14 °F to 122 °F)
<b>General</b>		
Certification		RoHS 2.0

## Dimension

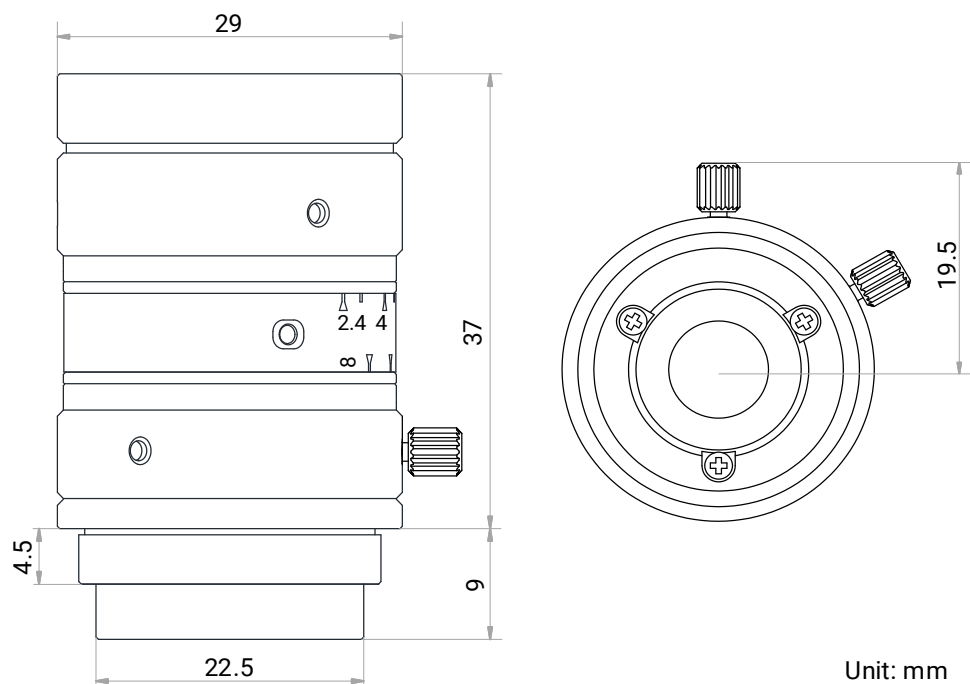

Unit: mm

## Field of View

Extension (mm)	Working Distance (mm)		Magnification	Field of View (mm)			
				1/1.8"		1/2"	
				H(7.38mm)	V(4.92mm)	H(6.22mm)	V(4.67mm)
10	near	0.55	-0.945	8.02	5.27	6.71	4.99
	far	1.67	-0.827	9.19	6.03	7.68	5.71
5	near	10.5	-0.528	14.31	9.42	11.98	8.94
	far	16	-0.417	18.13	11.93	15.17	11.31
2	near	31.3	-0.275	27.29	18.05	22.90	17.12
	far	58.8	-0.168	44.42	29.44	37.33	27.93
1	near	50.3	-0.191	39.08	25.92	32.85	24.59
	far	130	-0.084	87.95	58.51	74.05	55.52
0		100	-0.106	69.83	46.47	58.80	44.10
		150	-0.074	100.55	66.98	84.72	63.57
		200	-0.056	131.17	87.44	110.57	82.99
		250	-0.046	161.78	107.89	136.39	102.40
		300	-0.038	192.35	128.31	162.20	121.79
		350	-0.033	222.91	148.74	187.99	141.18
		400	-0.029	253.44	169.15	213.77	160.55
		450	-0.026	283.98	189.56	239.55	179.93
		500	-0.023	314.51	209.97	265.32	199.31
		550	-0.021	345.05	230.38	291.10	218.68
		600	-0.02	375.57	250.78	316.86	238.05
		650	-0.018	406.10	271.18	342.63	257.42
		700	-0.017	436.63	291.59	368.40	276.79
		800	-0.015	497.67	332.39	419.93	315.52
	900	-0.013	558.73	373.20	471.47	354.26	
	1000	-0.012	619.80	414.02	523.02	393.02	