

MV-VC310*X

VC3000 Series Vision Controller



Introduction

MV-VC310*X vision controller adopts Intel® G6900 CPU, and supports 8 GB memory. It supports 24-channel GPIO, and has multiple interfaces, such as, GigE, USB 2.0, and USB 3.0. It is designed for mainstream vision applications, providing support for multi-camera locating, detection, and recognition.

Key Feature

- Adopts 12th generation Intel® CPU to offer strong performance.
- Provides extended slot to connect with image frame grabbers.
- Supports 24-channel GPIO and NPN/PNP switching for output.
- Adopts GigE interfaces for high-speed and stable data transmission.

Available Model

- MV-VC3101X-128G60 (128 GB SSD)
- MV-VC3102X-128G60 (128 GB SSD + 2 TB HDD)

Applicable Industry

Consumer electronics, transportation, food and pharmaceutical, etc.

Dimension

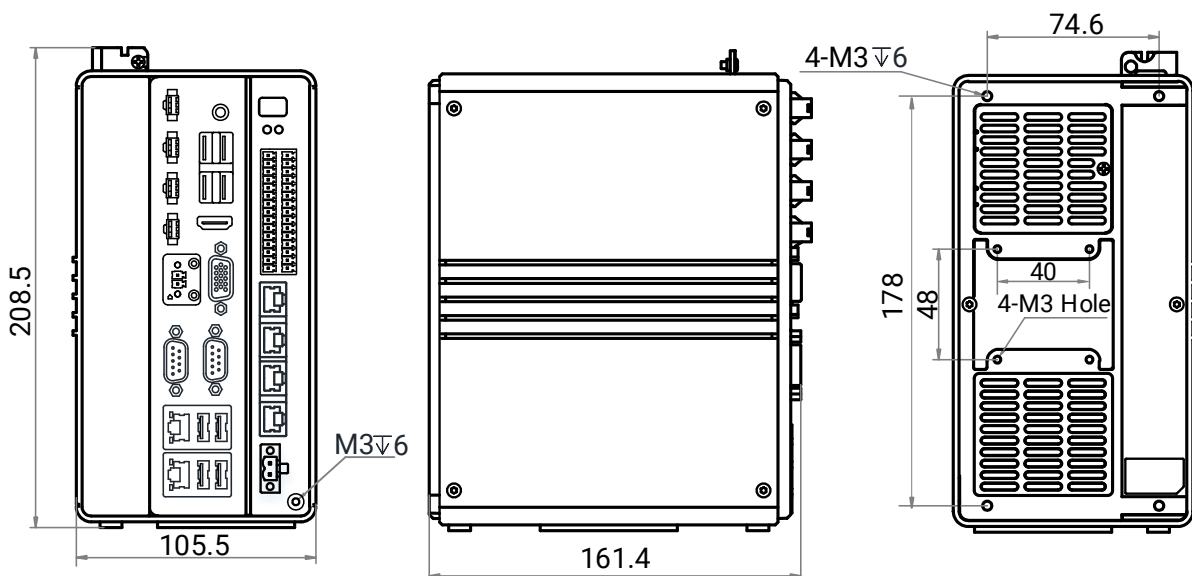

Unit: mm

Specification

HIKROBOT

Model	MV-VC3101X-128G60	MV-VC3102X-128G60
Performance		
CPU	Intel®@ Core 12 th Celeron® G6900	
Memory	8 GB	
Storage	128 GB SSD	128 GB SSD + 2 TB HDD, mSATA interface × 1
GPU	Intel® HD Graphics 710	
Operating system	Unactivated Windows 10	
External interface		
Video output	HDMI interface × 1, VGA interface × 1 Supports independent display outputs at the same time Max. resolution 1920 × 1080 @60 Hz (HDMI interface) Max. resolution 1920 × 1440 @60 Hz (VGA interface)	
Digital I/O	Opto-isolated input × 8, opto-isolated output × 16 Output supports NPN/PNP switch	
Network interface	GigE interface × 6, including Intel® GigE interface × 2, Netswift GigE interface × 4	
USB interface	USB 2.0 × 4, USB 3.0 × 4	
Serial port	RS-232 × 2, supports switching to RS-485 and RS-422	
Light interface	24 VDC constant voltage × 4 (Max. power consumption of single channel is 72 W, total max. power consumption 80 W.)	
Electrical feature		
Power supply	24 VDC	
Power consumption	Typ. 144 W	
Mechanical		
Dimension	161.4 mm × 208.5 mm × 105.5 mm (6.4" × 8.2" × 4.2")	
Weight	Approx. 2.1 kg (4.6 lb.)	
Temperature	0 °C to 50 °C (32 °F to 122 °F)	
Humidity	20% RH to 95% RH (no condensation)	
General		
Certification	CE, KC	