

MV-PE5101/-P

Built-In Amplifier Photoelectric Sensor



CE RoHS

Introduction

MV-PE5101/-P through-beam photoelectric sensor adopts specialized chips, offering advantages like simplicity, reliability, ease of alignment, and fast response. It supports light-on/dark-on switch.

Key Features

- Provides a large red spot for ease of alignment.
- Remains unaffected if exposed to direct sunlight with strong anti-interference capability.
- Requires no adjustment with ease of use.

Available Model

- PNP type: MV-PE5101-P
- NPN type: MV-PE5101

Applicable Industry

Logistics and industrial manufacturing.

Dimension

Transmitter:

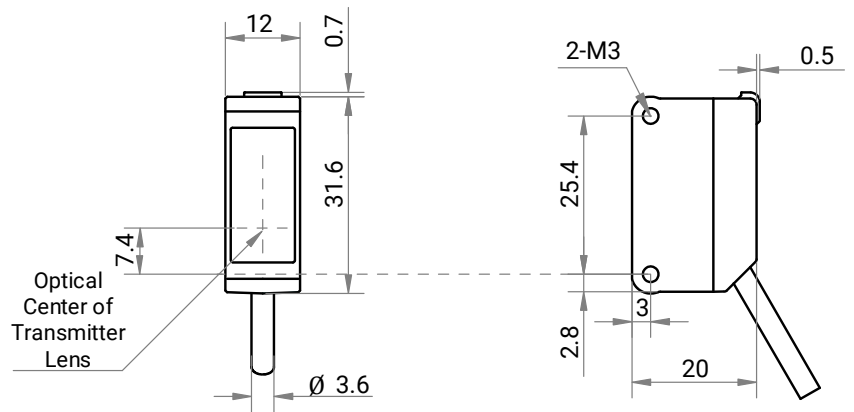

Unit: mm

Receiver:

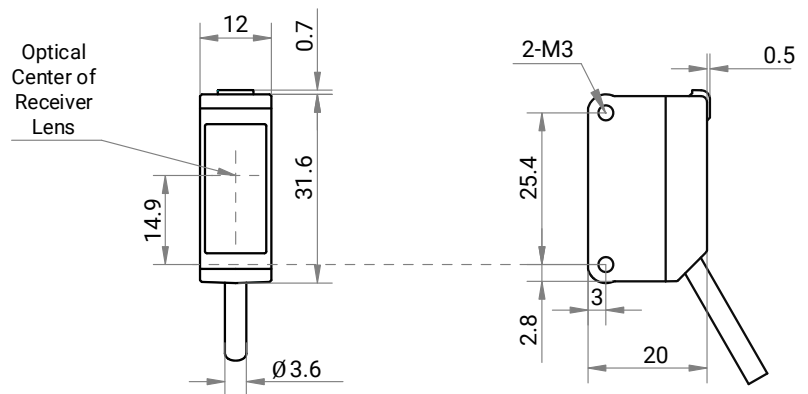

Unit: mm

Specification

	Model	MV-PE5101-P	MV-PE5101
Parameter	Built-In Amplifier Photoelectric Sensor		
Performance			
Detecting distance	15 m		
Sensing target	Opaque object above $\Phi 15$ mm		
Output	PNP-NO/NC (supports light-on/dark-on switch)		NPN-NO/NC (supports light-on/dark-on switch)
Light source	Red LED 660 nm		
Response time	$\leq 500 \mu\text{s}$		
Repeatability (perpendicular to sensing axis)	≤ 0.5 mm		
Electrical feature			
Supply voltage	12 VDC to 24 VDC $\pm 10\%$, including Ripple (P-P) 10% or less		
Residual voltage	≤ 2 VDC		
Operating current	≤ 20 mA		
Max. sink/source current	≤ 100 mA		
Circuit protection	Reverse polarity protection, overcurrent protection, and overvoltage protection		
Insulation resistance	20 M Ω or more (between the terminal block for power supply and the housing)		
Withstand voltage	1000 VAC, 1 min (between the terminal block for power supply and the housing)		
Mechanical			
Dimension	20 mm \times 12 mm \times 31.6 mm (0.8" \times 0.5" \times 1.2")		
Weight	Transmitter: approx. 45 g (0.1 lb.) (including cable) Receiver: approx. 45 g (0.1 lb.) (including cable)		
Temperature	Working temperature: -25°C to 55°C (-13°F to 131°F) Storage temperature: -30°C to 70°C (-22°F to 158°F)		
Humidity	35% RH to 85% RH		
Ambient illumination	Sunlight: < 10000 lux Incandescent lamp: < 3000 lux		
Ingress protection	IP67		
Material	Housing: polycarbonate Lens: acrylic		
Indicator	Operation indicator: orange (receiver) Stability indicator: green (receiver) Power indicator: orange (transmitter)		
Connecting method	Cable lead-out (standard length: 2 m, 78.7")		
Vibration resistance	10 Hz to 500 Hz, double amplitude 1.5 mm (0.1"), 2 hours in each of the X, Y, and Z directions		
Shock resistance	500 m/s ² , 3 times in each of the X, Y, and Z directions		
General			
Certification	CE, RoHS		

Wiring Method

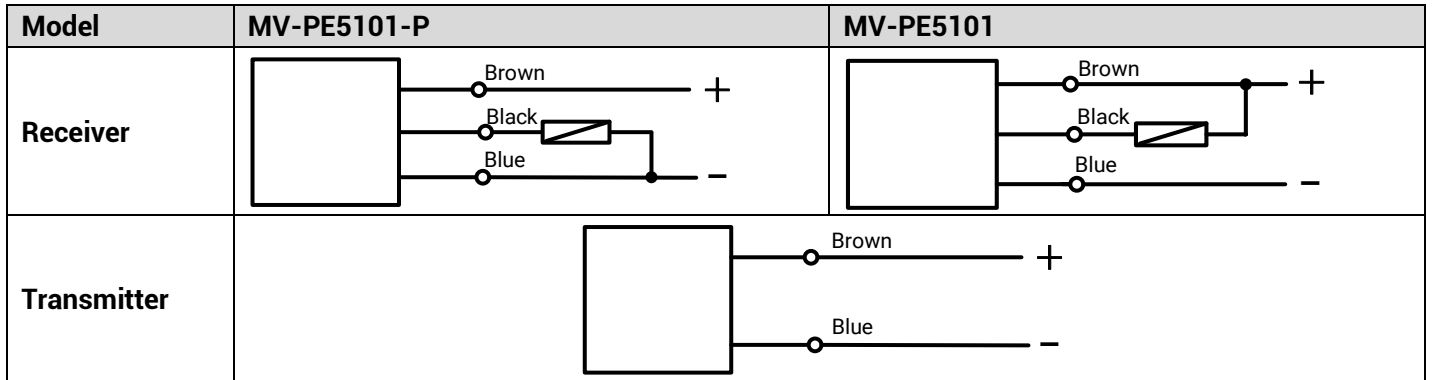

Relationship of Detection Status and Indicators

	Detection Status	Output	Operation Indicator	Stability Indicator
Light-ON/LO	Stable, incident light	ON	ON ¹	ON
	Unstable, incident light			OFF
	Unstable, no incident light	OFF	OFF ²	ON
	Stable, no incident light			ON
Dark-ON/DO	Stable, incident light	OFF	OFF	ON
	Unstable, incident light			OFF
	Unstable, no incident light	ON	ON	OFF
	Stable, no incident light			ON

Note:

1. The operation indicator is ON: The amount of incident light entering the receiver is above the operating level.
2. The operation indicator is OFF: The amount of incident light entering the receiver is below the operating level.

Spot Diameter

