

Hikrobot Co., Ltd.

Spot Light Controller

User Manual

HIKROBOT

Legal Information

© Hangzhou Hikrobot Co., Ltd. All rights reserved.

About this Document

This Document includes instructions for using and managing the Product. Pictures, charts, images and all other information hereinafter are for description and explanation only. The information contained in the Document is subject to change, without notice, due to firmware updates or other reasons. Please find the latest version in the company website (<https://en.hikrobotics.com/>). Unless otherwise agreed, Hangzhou Hikrobot Co., Ltd. or its affiliates (hereinafter referred to as "Hikrobot") makes no warranties, express or implied. Please use the Document with the guidance and assistance of professionals trained in supporting the Product.

Acknowledgment of Intellectual Property Rights

- Hikrobot owns the copyrights and/or patents related to the technology embodied in the Products described in this Document, which may include licenses obtained from third parties. Any part of the Document, including text, pictures, graphics, etc., belongs to Hikrobot. No part of this Document may be excerpted, copied, translated, or modified in whole or in part by any means without written permission.
- **HIKROBOT** and other Hikrobot's trademarks and logos are the properties of Hikrobot in various jurisdictions. Other trademarks and logos mentioned are the properties of their respective owners.

LEGAL DISCLAIMER

TO THE MAXIMUM EXTENT PERMITTED BY APPLICABLE LAW, THIS MANUAL AND THE PRODUCT DESCRIBED, WITH ITS HARDWARE, SOFTWARE AND FIRMWARE, ARE PROVIDED "AS IS" AND "WITH ALL FAULTS AND ERRORS". HIKROBOT MAKES NO WARRANTIES, EXPRESS OR IMPLIED, INCLUDING WITHOUT LIMITATION, MERCHANTABILITY, SATISFACTORY QUALITY, OR FITNESS FOR A PARTICULAR PURPOSE. THE USE OF THE PRODUCT BY YOU IS AT YOUR OWN RISK. IN NO EVENT WILL HIKROBOT BE LIABLE TO YOU FOR ANY SPECIAL, CONSEQUENTIAL, INCIDENTAL, OR INDIRECT DAMAGES, INCLUDING, AMONG OTHERS, DAMAGES FOR LOSS OF BUSINESS PROFITS, BUSINESS INTERRUPTION, OR LOSS OF DATA, CORRUPTION OF SYSTEMS, OR LOSS OF DOCUMENTATION, WHETHER BASED ON BREACH OF CONTRACT, TORT (INCLUDING NEGLIGENCE), PRODUCT LIABILITY, OR OTHERWISE, IN CONNECTION WITH THE USE OF THE PRODUCT, EVEN IF HIKROBOT HAS BEEN ADVISED OF THE POSSIBILITY OF SUCH DAMAGES OR LOSS.

YOU ACKNOWLEDGE THAT THE NATURE OF INTERNET PROVIDES FOR INHERENT SECURITY RISKS, AND HIKROBOT SHALL NOT TAKE ANY RESPONSIBILITIES FOR ABNORMAL OPERATION, PRIVACY LEAKAGE OR OTHER DAMAGES RESULTING FROM CYBER-ATTACK, HACKER ATTACK, VIRUS INFECTION, OR OTHER INTERNET SECURITY RISKS; HOWEVER, HIKROBOT WILL PROVIDE TIMELY TECHNICAL SUPPORT IF REQUIRED.

YOU AGREE TO USE THIS PRODUCT IN COMPLIANCE WITH ALL APPLICABLE LAWS, AND

YOU ARE SOLELY RESPONSIBLE FOR ENSURING THAT YOUR USE CONFORMS TO THE APPLICABLE LAW. ESPECIALLY, YOU ARE RESPONSIBLE, FOR USING THIS PRODUCT IN A MANNER THAT DOES NOT INFRINGE ON THE RIGHTS OF THIRD PARTIES, INCLUDING WITHOUT LIMITATION, RIGHTS OF PUBLICITY, INTELLECTUAL PROPERTY RIGHTS, OR DATA PROTECTION AND OTHER PRIVACY RIGHTS. YOU SHALL NOT USE THIS PRODUCT FOR ANY PROHIBITED END-USES, INCLUDING THE DEVELOPMENT OR PRODUCTION OF WEAPONS OF MASS DESTRUCTION, THE DEVELOPMENT OR PRODUCTION OF CHEMICAL OR BIOLOGICAL WEAPONS, ANY ACTIVITIES IN THE CONTEXT RELATED TO ANY NUCLEAR EXPLOSIVE OR UNSAFE NUCLEAR FUEL-CYCLE, OR IN SUPPORT OF HUMAN RIGHTS ABUSES.

THE PERFORMANCE DATA IN THIS PUBLICATION IS BASED ON HIKROBOT'S INTERNAL RESEARCH/EVALUATION. ACTUAL DATA MAY VARY DEPENDING ON SPECIFIC CONFIGURATIONS AND OPERATING CONDITIONS AND HIKROBOT SHALL NOT BEAR THE CONSEQUENCES ARISING THEREFROM.

IN THE EVENT OF ANY CONFLICTS BETWEEN THIS MANUAL AND THE APPLICABLE LAW, THE LATTER PREVAILS.

Regulatory Information

Note

These clauses apply only to the products bearing the corresponding mark or information.

EU Conformity Statement



This product and - if applicable - the supplied accessories too are marked with "CE" and comply therefore with the applicable harmonized European standards listed under the Directive 2014/30/EU(EMCD), Directive 2001/95/EC(GPSD) and Directive 2011/65/EU(RoHS).



2012/19/EU (WEEE directive): Products marked with this symbol cannot be disposed of as unsorted municipal waste in the European Union. For proper recycling, return this product to your local supplier upon the purchase of equivalent new equipment, or dispose of it at designated collection points. For more information see: <http://www.recyclethis.info>



Regulation (EU) 2023/1542(Battery Regulation): This product contains a battery and it is in conformity with the Regulation (EU) 2023/1542. The battery cannot be disposed of as unsorted municipal waste in the European Union. See the product documentation for specific battery information. The battery is marked with this symbol, which may include lettering to indicate cadmium (Cd), or lead (Pb). For proper recycling, return the battery to your supplier or to a designated collection point. For more information see: www.recyclethis.info



KC Mark Certification

Class A: The device is advised to note that as a seller or a business user (Class A) Devices and intended for use outside the Home area.

A급 기기: 이 기기는 업무용(A급) 전자파적합기기로서 판매자 또는 사용자는 이 점을 주의하시기바라며, 가정 외의 지역에서 사용하는 것을 목적으로 합니다.

Symbol Conventions

The symbols that may be found in this document are defined as follows.

Symbol	Description
 Danger	Indicates a hazard with a high level of risk, which if not avoided, will result in death or serious injury.
 Caution	Indicates a potentially hazardous situation which, if not avoided, could result in equipment damage, data loss, performance degradation, or unexpected results.
 Note	Provides additional information to emphasize or supplement important points of the main text.

Available Model

This manual is applicable to the Spot Light Controller.

Contact Information

Hangzhou Hikrobot Co., Ltd.

E-mail: global.support@hikrobotics.com

Website: <https://en.hikrobotics.com/>

Contents

Chapter 1 Safety Instruction	1
1.1 Safety Claim.....	1
1.2 Safety Instruction.....	1
1.3 Electromagnetic Interference Prevention	2
Chapter 2 Overview	4
2.1 Introduction.....	4
2.2 Key Features	4
Chapter 3 Appearance	5
Chapter 4 Device Installation and Connection	7
4.1 Installation Preparation	7
4.2 Install Device.....	7
4.3 Connect Device.....	9
Chapter 5 Device Control Panel and Wiring	10
5.1 Control Panel.....	10
5.2 Display Screen.....	12
5.3 Channel Button.....	12
5.4 RS-232 Serial Port.....	13
5.5 Trigger Input Interface	14
5.5.1 Pin Definition.....	14
5.5.2 Trigger Input Wiring	14
5.6 Trigger Output Interface	16
5.6.1 Pin Definition.....	16
5.6.2 Trigger Output Wiring	17
5.7 Light Source Interface	19
5.7.1 SMR-03V-BC Interface	19
5.7.2 12M-5F Interface.....	19
Chapter 6 Client Software Operation	21
6.1 Install MVS Client Software	21
6.2 Set PC Environment.....	22

6.2.1 Turn off Firewall	22
6.2.2 Set PC Network	23
6.3 Set Device Network	23
6.4 Operate MVS Client Software.....	24
6.5 Set Light Control	26
6.6 Set Timer Control	32
6.7 Set Digital IO Control	28
6.7.1 Set IO Input	28
6.7.2 Set IO Output.....	30
6.8 View Device Control.....	34
6.9 Update Firmware	35
Chapter 7 Light Controller Configuration Tool.....	37
7.1 Main Window.....	37
7.2 Connect Device via Controller	38
7.3 Light Source Control.....	40
7.4 I/O Control Input.....	40
7.5 I/O Control Output	41
7.6 Timer.....	42
7.7 Command Line	43
7.8 Update Firmware	44
Chapter 8 FAQ (Frequently Asked Question).....	46
8.1 Why PWR indicator on the control panel is unlit?	46
8.2 Why light source devices cannot be turned on?	46
8.3 Why light source devices cannot be triggered?	46
8.4 Why light source lights off intermittently?	46
Chapter 9 Revision History	48

Chapter 1 Safety Instruction

The safety instructions are intended to ensure that the user can use the device correctly to avoid danger or property loss. Read and follow these safety instructions before installing, operating and maintaining the device.

1.1 Safety Claim

- To ensure personal and device safety, when installing, operating, and maintaining the device, follow the signs on the device and all safety instructions described in the manual.
- The note, caution and danger items in the manual do not represent all the safety instructions that should be observed, but only serve as a supplement to all the safety instructions.
- The device should be used in an environment that meets the design specifications, otherwise it may cause malfunctions, and malfunctions or component damage caused by non-compliance with relevant regulations are not within the scope of the device's quality assurance.
- Our company will not bear any legal responsibility for personal safety accidents and property losses caused by abnormal operation of the device.

1.2 Safety Instruction



Caution

- Do not install the device if it is found that the device and accessories are damaged, rusted, water ingress, model mismatch, missing parts, etc., when unpacking.
- Avoid storage and transportation in places such as water splashing and rain, direct sunlight, strong electric fields, strong magnetic fields, and strong vibrations.
- Avoid dropping, smashing or vigorously vibrating the device and its components.
- It is forbidden to install the indoor device in an environment where it may be exposed to water or other liquids. If the device is damp, it may cause fire and electric shock hazard.
- Place the device in a place out of direct sunlight and ventilation, away from heat sources such as heaters and radiators.
- This is a Class A device. In the living environment, this device may cause radio interference. In this case, the user may be required to take practical measures against the interference.
- In the use of the device, you must be in strict compliance with the electrical safety regulations of the nation and region.
- Use the power adapter provided by the official manufacturer. The power adapter must meet the Limited Power Source (LPS) requirements. For specific requirements, please refer to the device's technical specifications.
- Do not cover the device's plug or outlet for disconnecting power supply.

- It is strictly forbidden to wire, maintain, and disassemble the device is powered on. Otherwise, there is a danger of electric shock.
- Make sure that the device is installed in good condition, the wiring is firm, and the power supply meets the requirements before powering on the device.
- If the device emits smoke, odor or noise, please turn off the power and unplug the power cord immediately, and contact the dealer or service center in time.
- If the device does not work properly, please contact your dealer or the nearest service center. Never attempt to disassemble the device yourself. We shall not assume any responsibility for problems caused by unauthorized repair or maintenance.
- Please dispose of the device in strict accordance with the relevant national or regional regulations and standards to avoid environmental pollution and property damage.

Note

- Check whether the device's package is in good condition, whether there is damage, intrusion, moisture, deformation, etc. before unpacking.
- Check the surface of the device and accessories for damage, rust, bumps, etc. when unpacking.
- Check whether the quantity and information of the device and accessories are complete after unpacking.
- Store and transport the device according to the storage and transport conditions of the device, and the storage temperature and humidity should meet the requirements.
- It is strictly prohibited to transport the device in combination with items that may affect or damage the device.
- Quality requirements for installation and maintenance personnel:
 - Qualification certificate or working experience in weak current system installation and maintenance, and relevant working experience and qualifications. Besides, the personnel must possess the following knowledge and operation skills.
 - The basic knowledge and operation skills of low voltage wiring and low voltage electronic circuit connection.
 - The ability to comprehend the contents of this manual.
- Please read the manual and safety instructions carefully before installing the device.
- Please install the device strictly according to the installation method in this manual.
- Do not contact the device with strong acids, alkalis, oils, greases or organic solutions such as thinners.

1.3 Electromagnetic Interference Prevention

- Make sure that the shielding layer of cables is intact and 360° connected to the metal connector when using shielded cables.
- Do not route the device together with other equipment (especially servo motors, high-power devices, etc.), and control the distance between cables to more than 10 cm. Make sure to shield the cables if unavoidable.
- The control cable of the device and the power cable of the industrial light source must be wired separately to avoid bundled wiring.

Spot Light Controller User Manual

- The power cable, data cable, signal cable, etc. of the device must be wired separately. Make sure to ground them if the wiring groove is used to separate the wiring and the wiring groove is metal.
- During the wiring process, evaluate the wiring space reasonably, and do not pull the cables hard, so as not to damage the electrical performance of the cables.
- The unused cables of the device must be insulated.
- To avoid the accumulation of static electricity, ensure that other equipment (such as machines, internal components, etc.) and metal brackets on site are properly grounded.
- During the installation and use of the device, high voltage leakage must be avoided.
- Use a figure-eight bundle method if the device cable is too long.
- When connecting the device and metal accessories, they must be connected firmly to maintain good conductivity.
- Use a shielded network cable to connect to the device. If you use a self-made network cable, make sure that the shielding shell at the aviation head is well connected to the aluminum foil or metal braid of the shielding cable.

Chapter 2 Overview

2.1 Introduction

The spot light controller supports outputting multichannel light sources and different control modes of light source, and provides I/O connectors, device management interface, and corresponding light source controller software. It helps users realize fast and convenient deployment of light source on site.

2.2 Key Features

- Supports different control modes of light source, including control panel and software.
- Supports using serial port or network interface to set parameters and manage the device.
- Provides multichannel inputs and outputs.
- Supports installation via slide rail or screw hole.
- Supports overcurrent, overload, short circuit protection.
- Supports power-off protection to save configured parameters.

 **Note**

- Refer to the device's specifications for detailed parameters.
 - The key feature may differ by device models.
-

Chapter 3 Appearance

Note

- Appearance here is for reference only. Refer to the device's specification for detailed dimension information.
- The specific appearance may differ by device models, and the actual device you purchased should prevail.

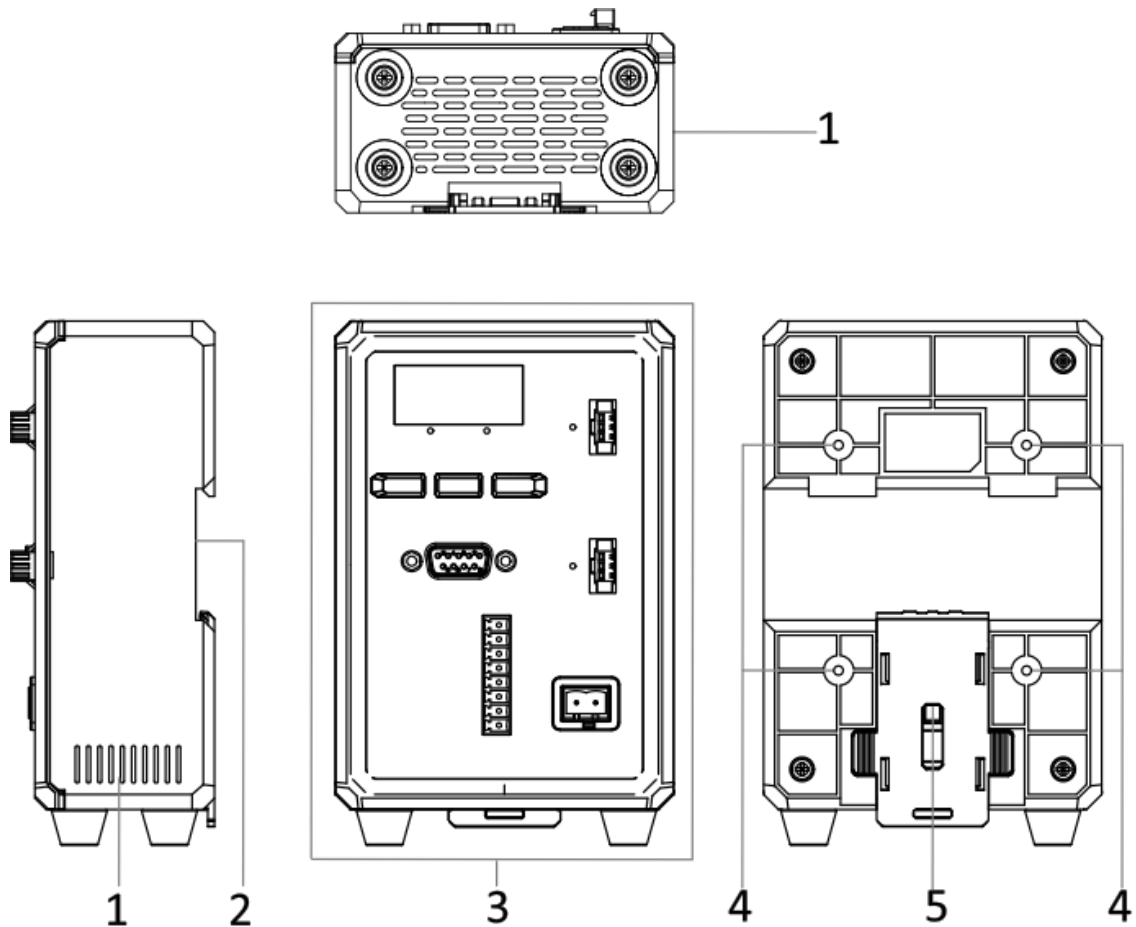



Figure 3-1 Appearance

Table 3-1 Component Description

No.	Name	Description
1	Ventilation Hole	It is used to cool the device.
2	Slide Rail Slot	It is used to install the device, and you should use standard Din35 slide rail.
3	Control Panel	It provides functions of power supply, network, serial port,

Spot Light Controller User Manual

No.	Name	Description
		digital I/O, indicator, button, display, etc. Refer to section Control Panel for details.  Note The control panel may differ by device models.
4	Screw Hole	It is used to install the device, and you should use M3 screws.
5	Plastic Pallet	It is used to fix the Din35 slide rail.

Chapter 4 Device Installation and Connection

4.1 Installation Preparation

You need to prepare following accessories before installation.

Table 4-1 Accessories

No.	Name	Quantity	Description
1	Power Cord	1	It refers to the suitable power cord, and you should select it according to the device's power supply and power consumption. Refer to the device's specifications for details. <ul style="list-style-type: none"> • 24 VDC power cord that you need to purchase separately. • 2-pin power supply socket is supplied.
2	Cable	1	You should use the serial port cable when adjusting the device's parameters via software.  Note Serial port extension cables need to be purchased separately.
3	I/O Terminal	1	One I/O terminals is provided. It is used to connect trigger input/output interface for wiring.
4	Screw Package	1	It refers to M3 × 7 screws, and they are included in the package.

4.2 Install Device

Before You Start

- Make sure that the device in the package is in good condition and all accessories are included.
- Make sure that all related devices are powered off during the installation.

The device supports two installation methods, including installation via slide rail and screw hole. Among them, screw hole installation is divided into rear installation and bottom installation.

Note

- The specific installation method may differ by device model, and you should select it according to actual demands.
- Here we take some models as examples to introduce installation, and appearance here is

for reference only.

Installation via Slide Rail

Steps

1. Pull the plastic pallet downward, and insert Din35 slide rail into the device's slide rail slot, as shown below.

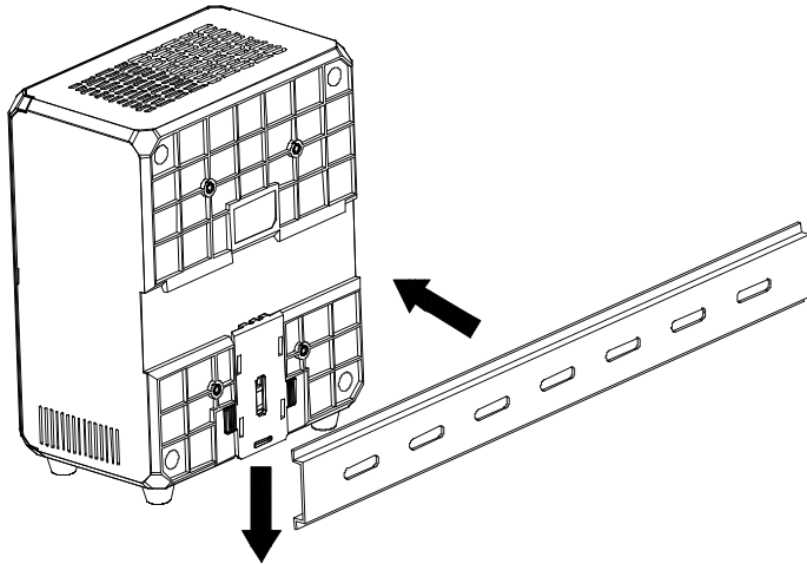

Figure 4-1 Installation via Slide Rail

2. Push the plastic pallet upward, and make sure that Din35 slide rail is fixed firmly.

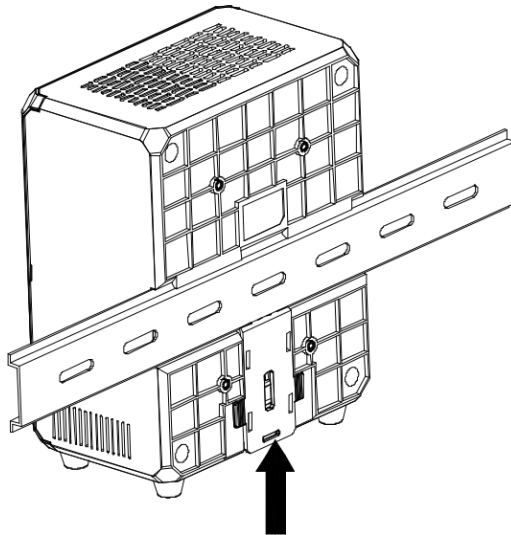

Figure 4-2 Fix Slide Rail

Installation via Screw Hole (Rear Side)

Use four supplied screws to fix the device from rear side to the installation position, as shown below.

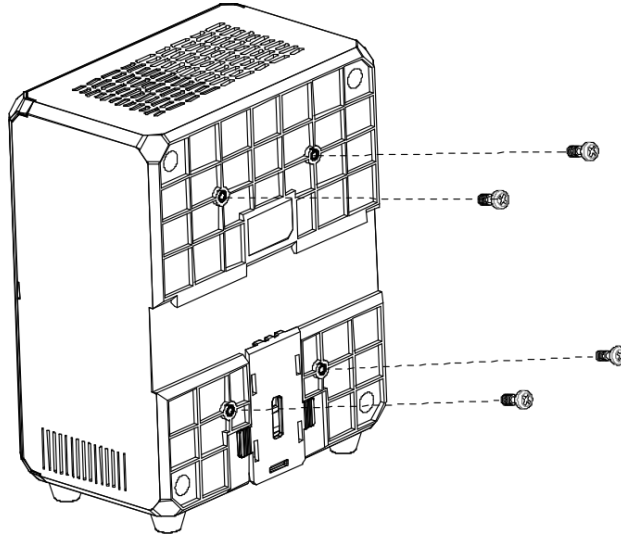

Figure 4-3 Installation via Screw Hole (Rear Side)

4.3 Connect Device

Steps

1. Insert external light sources to the device's light source interface.
2. Use power cord to connect the device to a power supply.
3. Use RS-232 serial port cable to connect the device if you need to connect the device to a PC via RS-232 serial port.

Note

- You can press the control panel to adjust light source brightness without serial port connection.
 - Refer to section [Control Panel](#) for detailed interface description.
 - For PC that does not support RS-232 serial port, you should use RS-232 to USB cable, and contact the cable manufacturer for the corresponding drive.
-

Chapter 5 Device Control Panel and Wiring

5.1 Control Panel

The device's control panel is shown below.

 **Note**

The control panel is different by device models.

The spot light controller currently has two types of devices. Refer to the table below for detailed information.

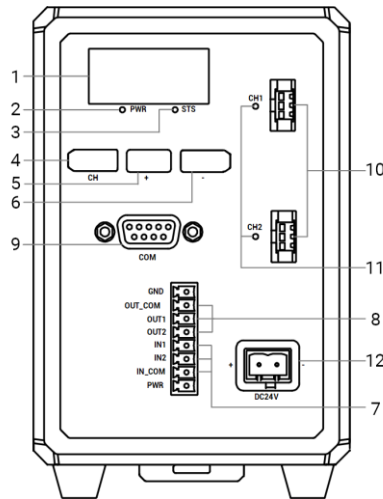

Figure 5-1 Control Panel (10 W Device)

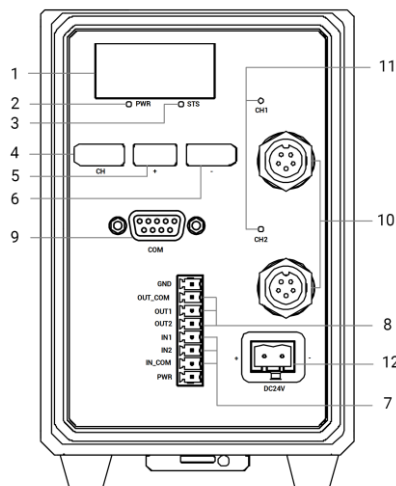



Figure 5-2 Control Panel (30 W Device)

Table 5-1 Control Panel Description

No.	Name	Description
1	Display Screen	Regarding the channels of external light sources connected to the display device and their corresponding brightness values, please refer to the section Display Screen .
2	PWR Indicator	It is a power indicator, and it is solid red when the device power connection is normal.
3	STS Indicator	It is a status indicator, and it is solid green when the device runs normally, and it is solid red when the device exception occurs.
4	Channel Button (CH)	Press it to switch the light source channels, light source brightness, and working modes of the device. For detailed introduction, please refer to the section Channel Button .
5	Brightness +	Press it to switch the working mode of the light source channel and increase the brightness value of the light source that are displayed as 2nd to 4th digits on the display screen.
6	Brightness -	Press it to switch the working mode of the light source channel and decrease the brightness value of the light source that are displayed as 2nd to 4th digits on the display screen.
7	Trigger Input Interface	It provides trigger input function. Refer to section Trigger Input Interface for details.
8	Trigger Output Interface	It provides trigger output function. Refer to section Trigger Output Interface for details.
9	RS-232 Serial Port	It provides data transmission function. Used for modifying device parameters through serial port control in the Demo, for specific instructions, please refer to the section RS-232 Serial Port .
10	Light Source Interface	It is used to connect external light sources. Refer to section Light Source Interface for details.  Note The devices have two light source interfaces (CH1 to CH2).
11	Light Source Indicator	It refers to light source indicators corresponding to light source interfaces (CH1 to CH2). <ul style="list-style-type: none"> ● The indicator is solid green when the device's working

No.	Name	Description
		mode is Triggered Always-On Mode. • The indicator is flashing green when the device's working mode is Triggered Always-Off Mode.
12	Power Interface	It is used to connect the power cord to power the device.  Note Do not replace the fuse in power interface by yourself if it is damaged. If necessary, contact technical support for help.

5.2 Display Screen

Through the device display, you can view the external light source channels of the device, the working mode of the channel, and the brightness value of the channel, as shown below.

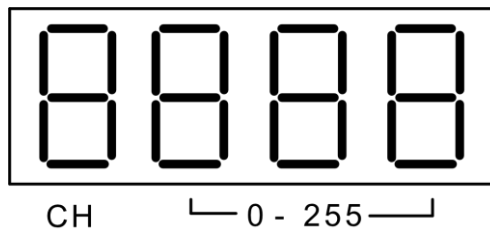

Figure 5-3 Display Screen

- When the display screen shows the external light source channel and its corresponding brightness value: the first digit represents the current device's light source channel, while the second to fourth digits indicate the brightness value of that channel, ranging from 0 to 255. A brightness value of 0 means the device is off, while a brightness value of 255 means the device is its max. brightness value.
- When the display screen shows the external light source channel and its working mode: the first digit indicates the light source channel of the device. If the second and third digits display “-”, the fourth digit shows the working mode, with “H” representing Triggered Always-On Mode and “L” representing Triggered Always-Off Mode. If the second to fourth digits display “Off”, it indicates the device is in a different working mode rather than Triggered Always-On or Triggered Always-Off Mode.

The display screen also allows you to check the parameter saving status. When the device saves the configured parameters, “SAVE” will appear on the screen. For more details on parameter saving, please refer to the sections on [View Device Control](#) [View Device Control](#) and [Main Window](#).

5.3 Channel Button

You can use the Channel Button to switch between the device's light source channels and working modes.

- When the device is powered on, the display screen shows CH1 by default and its brightness value. The first digit on the display screen shows "1" for CH1, and the second to fourth digits display the brightness value of CH1. You can press the "+" or "-" button to increase or decrease the brightness value.

Press the Channel Button once to switch the working mode for CH1. You can then use the "+" or "-" button to toggle between Triggered Always-On and Triggered Always-Off Mode.

- Press the Channel Button for the second time to switch the light source channel to CH2, with the first digit on the display screen showing "2". You can press the "+" or "-" button to increase or decrease the brightness value.

Press the Channel Button for the third time to switch the working mode for CH2. You can then use the "+" or "-" button to toggle between Triggered Always-On and Triggered Always-Off Mode.

Note

- To save the brightness and working mode settings, press the Channel Button again after completing the brightness value and working mode settings for all light source channels. When the first to the fourth digits on the display screen show "SAVE", you can press the "+" button to save the brightness value and working mode settings for all Channels.
 - If you set the brightness value and working mode for each channel but don't manually save, the device will automatically save the settings after two minutes.
-

5.4 RS-232 Serial Port

The device has one RS-232 serial port that can be connected to external devices like PC via common 9-pin female connector for data transmission. You can refer to the table below for the specific pin name and function.

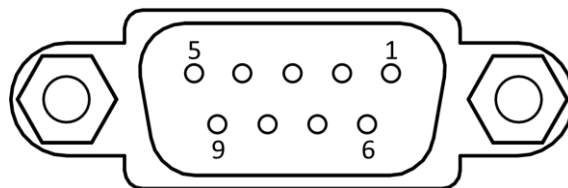

Figure 5-4 9-Pin Female Connector

Table 5-2 Pin Definitions of 9-Pin Female Connector

Pin No.	Name	Function
2	TX	Send data
3	RX	Receive data
5	GND	Signal ground

5.5 Trigger Input Interface

5.5.1 Pin Definition

The pin definition of trigger input interface is different by device models. You can refer to the following section for details.

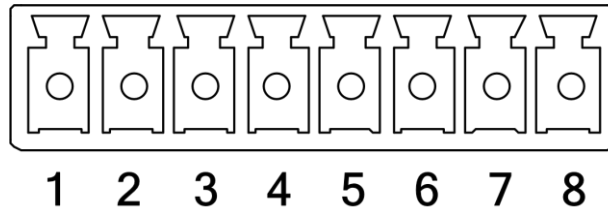

Figure 5-5 Trigger Input Interface

Table 5-3 Pin Definitions of Trigger Input Interface

Pin No.	Signal Name	Function
1	PWR	24 V power positive
2	IN_COM	Input common port (without polarity)
3	IN2	CH2 opto-isolated signal input
4	IN1	CH1 opto-isolated signal input
8	GND	External device power ground

5.5.2 Trigger Input Wiring

The device can receive input signal sent by external devices via trigger input interface.

Note

- Here we take IN1 signal as an example to introduce the trigger input wiring.
- Trigger input wiring may differ by external device type.
- The voltage of VCC should not be large than 24 V. Otherwise, the output signal exception may occur.
- Do not connect the device's power interface to other interfaces. Otherwise, short circuit may occur.

PNP Device as Input Signal

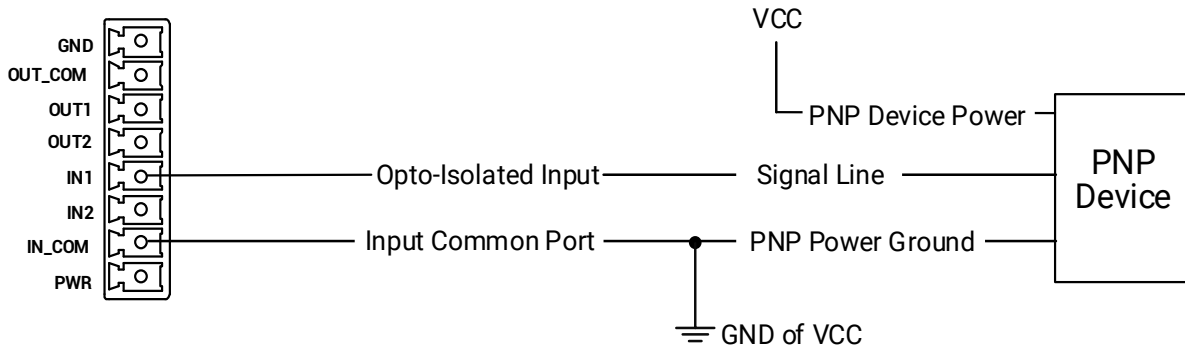

Figure 5-6 Input Signal Connecting to PNP Device (Method 1)

When the digital light controller’s PWR and GND are used to power the external device, the wiring diagram is shown below. The power supply is 24 V and max. output current is 150 mA.

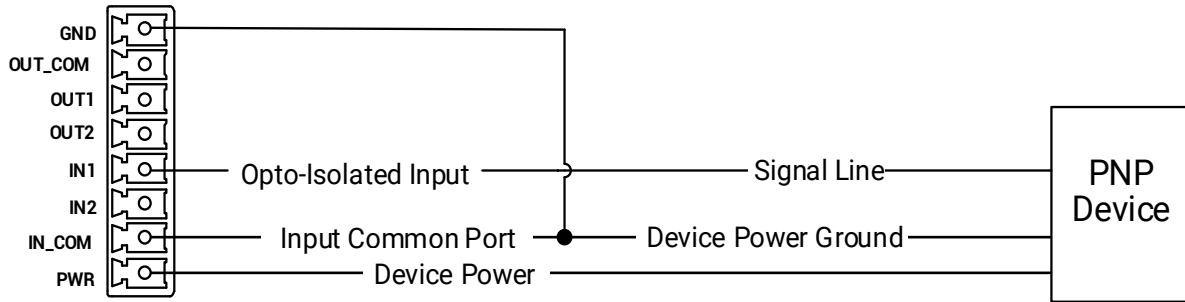

Figure 5-7 Input Signal Connecting to PNP Device (Method 2)

NPN Device as Input Signal

When the VCC of NPN device is 12 V or 24 V and without external resistor, the wiring diagram is shown below.

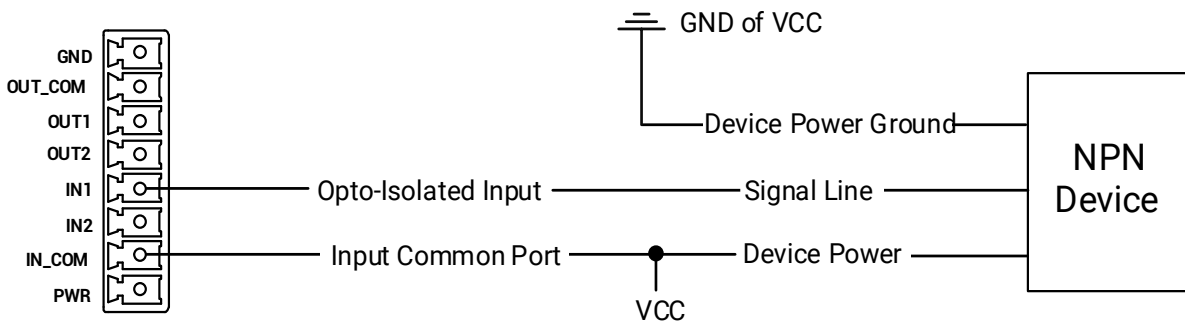

Figure 5-8 Input Signal Connecting to NPN Device (Without External Resistor)

When the VCC of NPN device is 12 V or 24 V and with pull-up resistor, the wiring diagram is

shown below.

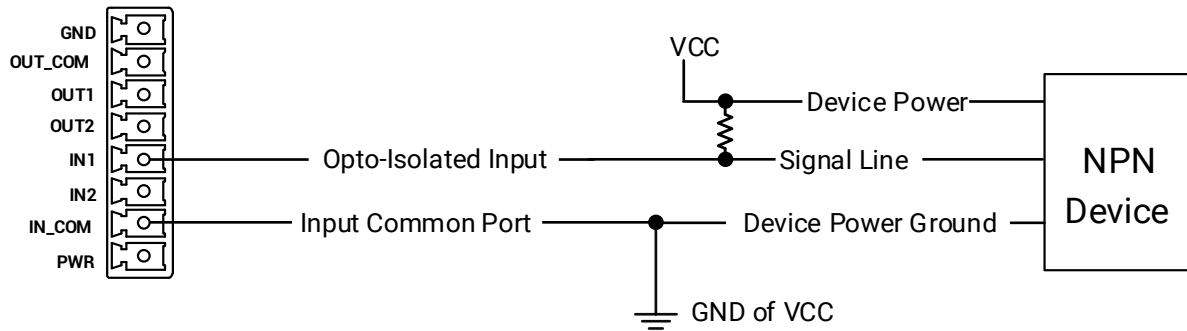

Figure 5-9 Input Signal Connecting to NPN Device (External Pull-Up Resistor Used)

The resistance value (R) may differ when the VCC of the device changes. Refer to the table below for details.

Table 5-4 Relation between VCC and Resistance

VCC	R
12 VDC	1 kΩ
24 VDC	4.7 kΩ

5.6 Trigger Output Interface

5.6.1 Pin Definition

The pin definition of trigger output interface is different by device models. You can refer to the following section for details.

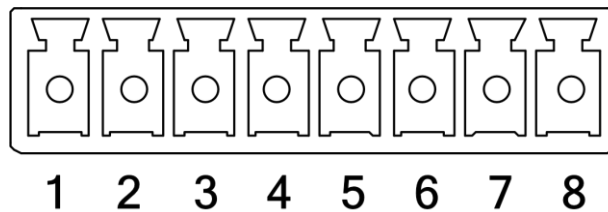

Figure 5-10 Trigger Output Interface

Table 5-5 Pin Definitions of Trigger Output Interface

Pin No.	Signal Name	Function
1	PWR	24 V power positive
5	OUT2	CH2 opto-isolated signal output

Pin No.	Signal Name	Function
6	OUT1	CH1 opto-isolated signal output
7	OUT_COM	Output common port (without polarity)
8	GND	External device power ground

5.6.2 Trigger Output Wiring

The device can send output signal to external devices via trigger output interface.

Note

- Here we take OUT1 signal as an example to introduce the trigger output wiring.
- Trigger output wiring may differ by external device type.
- The voltage of VCC should not be large than 24 V. Otherwise, the output signal exception may occur.
- Do not connect the device's power interface to other interfaces. Otherwise, short circuit may occur.

PNP Device as External Device

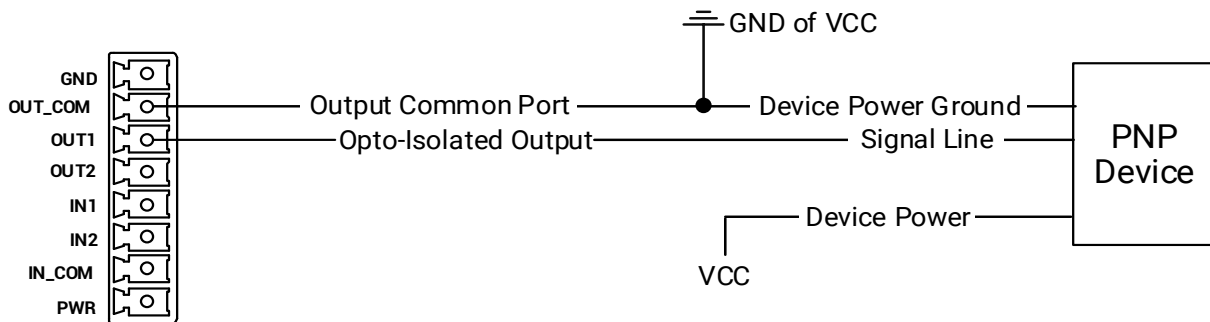

Figure 5-11 Output Signal Connecting to PNP Device (Method 1)

When the digital light controller's PWR and GND are used to power the external device, the wiring diagram is shown below. The power supply is 24 V and max. output current is 150

mA.

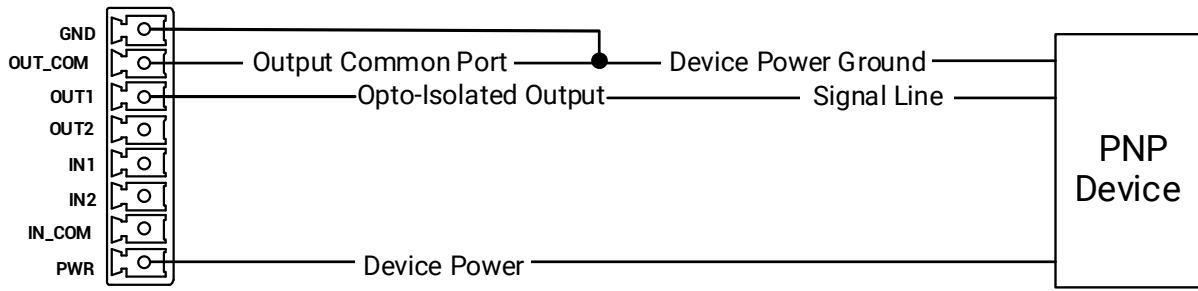

Figure 5-12 Output Signal Connecting to PNP Device (Method 2)

NPN Device as External Device

When the VCC of NPN device is 12 V or 24 V and without external resistance, the wiring diagram is shown below.

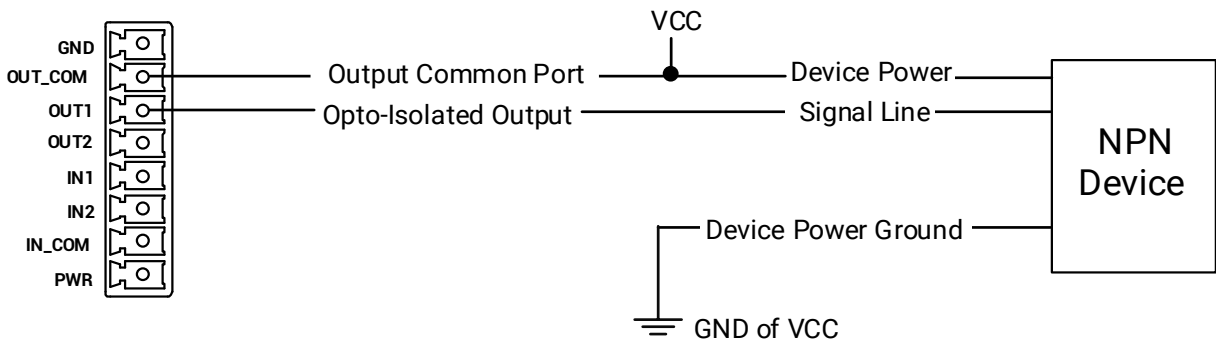

Figure 5-13 Output Signal Connecting to NPN Device (Without External Resistor)

When the VCC of NPN device is 12 V or 24 V and with pull-up resistance, the wiring diagram is shown below.

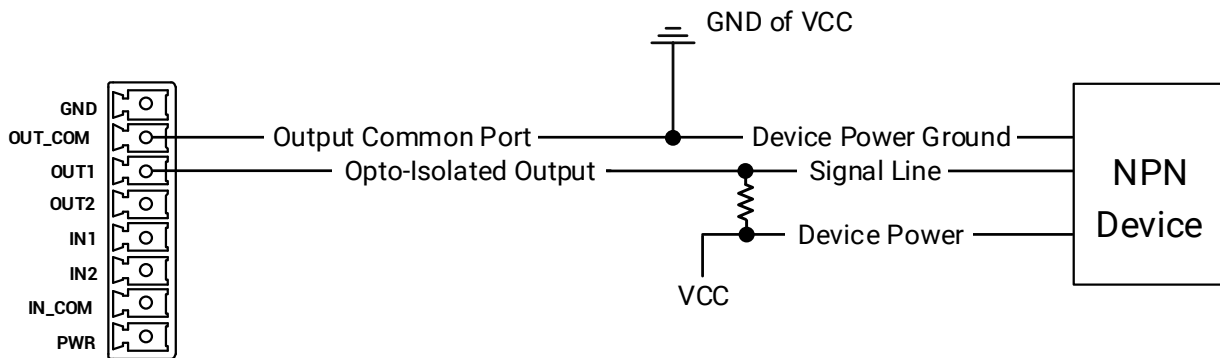

Figure 5-14 Output Signal Connecting to NPN Device (Pull-Up Resistor Used)

The resistance value (R) may differ when the VCC of the device changes. Refer to the table

below for details.

Table 5-6 Relation between VCC and Resistance

VCC	R
12 VDC	1 kΩ
24 VDC	4.7 kΩ

5.7 Light Source Interface

The device's light source interfaces can be connected to external light source devices via specific connector. There are two types of light source interfaces.

- 10 W device: SMR-03V-BC interface
- 30 W device: 12M-5F interface

Note

- The light source interface may differ by device models. Refer to the device's specifications for specific types.
 - The shell of connected external light source devices should meet V-0 flame retardant.
-

5.7.1 SMR-03V-BC Interface

10 W device adopts SMR-03V-BC interface as its light source interface, and the appearance is shown below.

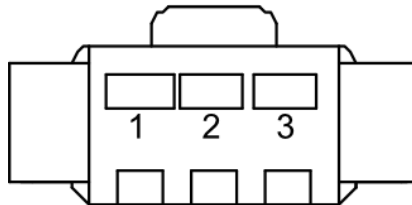

Figure 5-15 SMR-03V-BC Interface

The pin definition of SMR-03V-BC interface is shown below.

Table 5-7 Pin Definitions of SMR-03V-BC Interface

Pin No.	Name	Function
1	LED_R	Light source type recognition signal
2	LED +	Light source positive
3	LED -	Light source negative

5.7.2 12M-5F Interface

30 W device adopts 12M-5F interface as its light source interface, and the appearance is shown below.

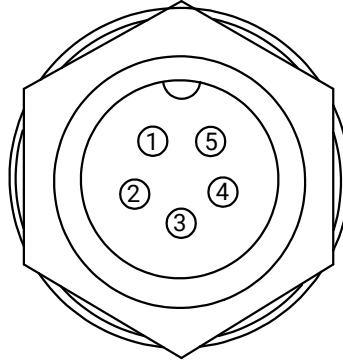

Figure 5-16 12M-5F Interface

Table 5-8 Pin Definitions of 12M-5F Interface

Pin No.	Name	Function
1	LED-	Light source negative
2	LED+	Light source positive
3	LED_R	Light source type recognition signal
4	5V	Fan power supply
5	GND	Fan power ground

Chapter 6 Client Software Operation

This section introduces how to use the MVS client software to set parameters of the device.

6.1 Install MVS Client Software

Note

- The MVS client software is compatible with 32/64-bit Windows 7/10, 64-bit Windows 11, and 32/64-bit Linux operating systems. Here we take Windows as an example.
 - The graphic user interface may differ by different versions of the client software you use.
 - The client software has integrated driver required by hardware, and no need to download and install other drivers.
 - You can download the client software from en.hikrobotics.com.
-

Steps

1. Double-click the MVS installation package.
2. Select the language.
3. Read and check **Terms of the License Agreement**.

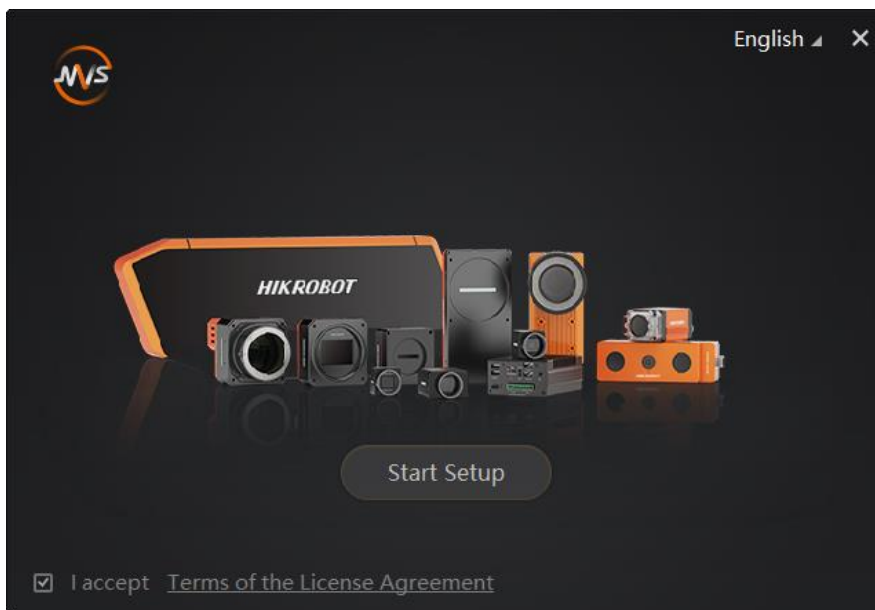

Figure 6-1 Installation Interface

4. Click **Start Setup**.

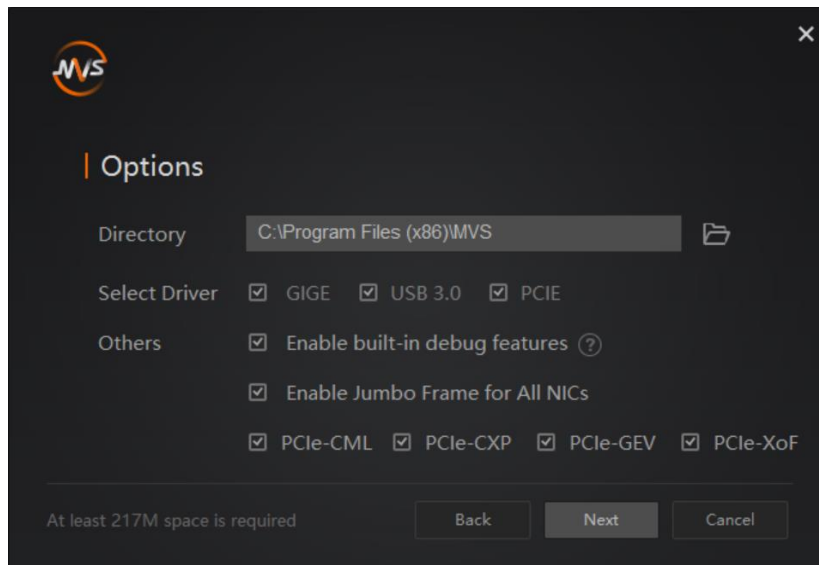

Figure 6-2 Default Settings

5. Keep default settings, and click **Next**.
6. Finish the installation according to the interface prompts.

6.2 Set PC Environment

To ensure stable client running and data transmission, you are recommended to set PC environment.

6.2.1 Turn off Firewall

Steps

Note

For different Windows versions, the path name or interface may differ. Please refer to the actual condition.

1. Go to Windows Firewall.
 - Windows 7 system: Click **Start** → **Control Panel** → **Windows Firewall**.
 - Windows 10 system: Click **Start** → **Control Panel** → **System and Security** → **Windows Defender Firewall**.
 - Windows 11 system: Click **Start** → **Settings** → **Privacy & security** → **Windows Security** → **Firewall & network protection**.
2. For Windows 7 and 10 system, click **Turn Windows Defender Firewall on or off** on the left. For Windows 11, select the network and turn off in **Microsoft Defender Firewall**.
3. Select **Turn off Windows Defender Firewall (not recommended)**.

- Turn on Windows Defender Firewall
 - Block all incoming connections, including those in the list of allowed apps
 - Notify me when Windows Defender Firewall blocks a new app
- Turn off Windows Defender Firewall (not recommended)

Figure 6-3 Windows Defender Firewall

4. Click OK.

6.2.2 Set PC Network

Steps

Note

For different Windows versions, the specific setting path and interface may differ. Please refer to the actual condition.

1. Go to PC network settings page: **Start** → **Control Panel** → **Network and Internet** → **Network and Sharing Center** → **Change adapter settings**.
2. Select NIC, and set the IP obtainment mode.
 - Select **Obtain an IP address automatically** to get an IP address of the PC automatically.
 - Or select **Use the following IP address** to set an IP address for the PC manually.

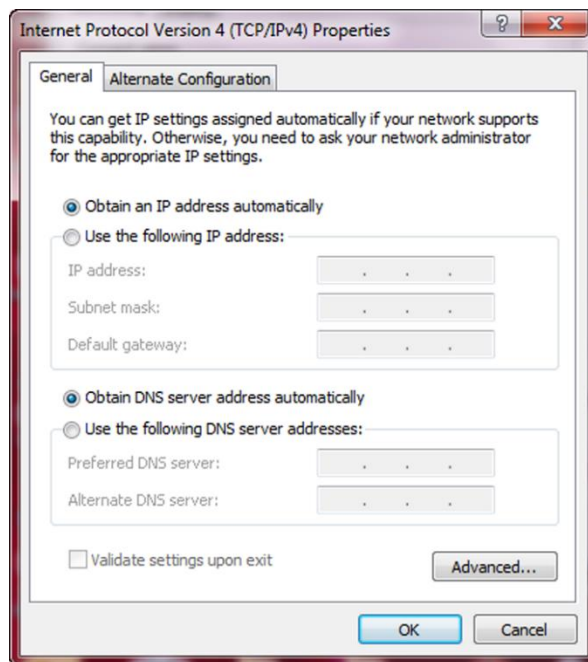



Figure 6-4 Set PC Network

6.3 Set Device Network

After the installation of the client software, if the device in the device list is unreachable, you should set the device's network.

Steps

1. Double-click the client software to run it, and the **Device List** window will pop up.
2. Click  in device list to search for the device.
3. Select a device to be connected.
4. Right-click the device, and click **Modify IP**.
5. Set **IP Address**, **Subnet Mask**, and **Default Gateway**.
6. Click **OK**.

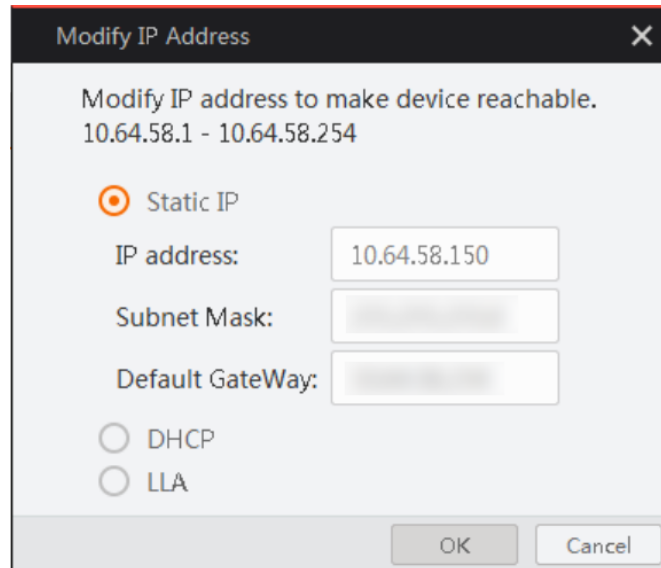

Figure 6-5 Set Device Network

6.4 Operate MVS Client Software

Note

Here we take devices with network interface as an example to introduce how to operate the MVS client software.

Steps

1. Double-click the client software to run it.
2. Click  in **Serial Port** to search the device.

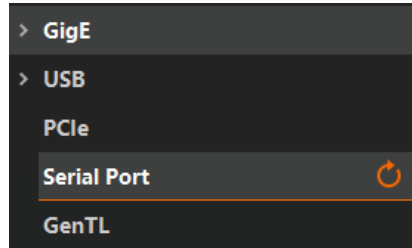



Figure 6-6 Search Device

3. Double-click the device or click  to connect the device to the client software. The main window of the client software is shown below.

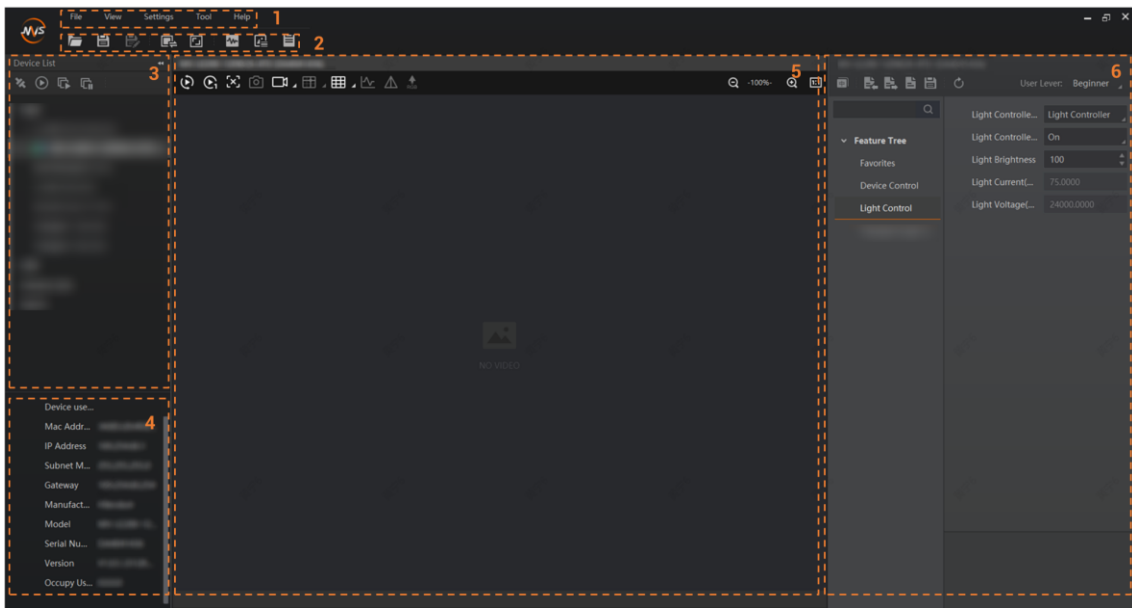

Figure 6-7 Main Window

 **Note**

For specific main window of the client software, please refer to the actual device you got.

Table 6-1 Main Window Description

No.	Name	Description
1	Menu Bar	The menu bar displays function modules, including File, View, Settings, Tool, and Help.
2	Control Toolbar	The control toolbar provides quick operations for the device.
3	Device List Panel	This panel displays device list, and you can connect or disconnect device, modify device IP address, etc.
4	Device Information Panel	This panel displays the detailed device information.

No.	Name	Description
5	Display Window	This area displays the images in real-time. You can click different icons to capture and save image, record, etc.
6	Feature Panel	It displays the device's features.

4. Click  in the device's feature panel to unfold the specific parameters, and set them according to actual demands.

 **Note**

The device's feature tree and parameters may differ by device models.

Table 6-2 Feature Tree Description

Feature Name	Description
Device Control	You can view device information, edit its name, reset the device, etc.
Light Control	You can set the device's brightness and working mode.
Digital IO Control	You can set the different input and output signals.
Counter and Timer Control	You can view and set the timer-related parameters.

6.5 Set Light Control

The light control configures brightness and working mode for different light source interfaces. The configuration method for light source control varies across different models of devices.

Before You Start

Make sure light sources are connected to the corresponding interfaces and other wirings completed.

Steps

1. Select correct channel from **Light Controller Selector** according to light source wirings.

 **Note**

- **Light Controller 1** to **Light Controller 2** is corresponding to CH1 to CH2.

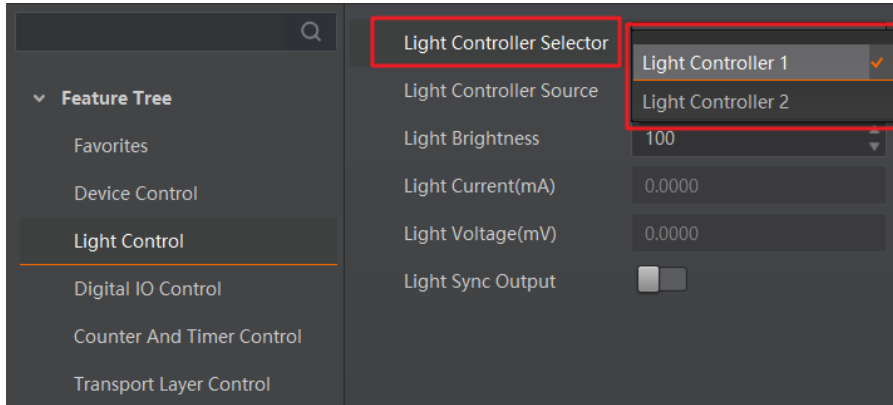

Figure 6-8 Light Controller Selector

2. Select different working modes from **Light Controller Source**.

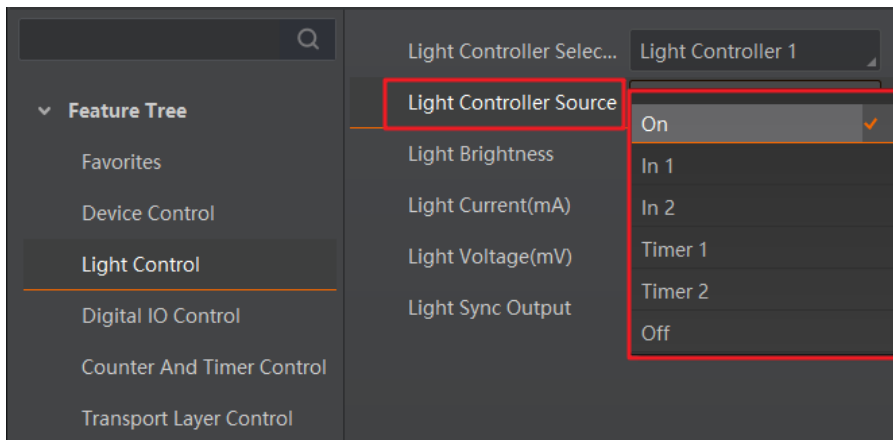

Figure 6-9 Light Controller Source

Table 6-3 Light Controller Source Description

Working Mode	Description
On	The light source is on all the time.
In 1/2	Use trigger input interface signal (IN 1/2) to control light source output.
Timer 1/2	Use timer 1/2 trigger signals to control light source output.
Off	The light source is off.

3. Set **Light Brightness**. The range is between 0 to 255.

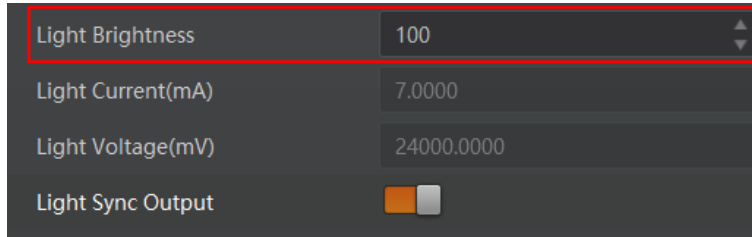

Figure 6-10 Set Light Brightness

4. (Optional) Enable **Light Sync Output** to let the settings of one light source apply to other light source channels.

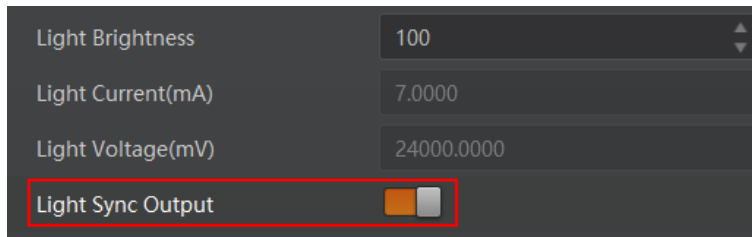

Figure 6-11 Enable Light Sync Output

Note

The parameter of **Light Sync Output** may differ by device models.

6.6 Set Digital IO Control

The device provides two configurable input signals (In 1 to In 2) and two configurable output signals (Out 1 to Out 2). You can go to Digital IO Control to set related parameters.

6.6.1 Set IO Input

The device can receive multiple input signals and invert the electrical level status of input signals.

Note

For specific details regarding the I/O input interface and wiring methods, please refer to section [Trigger Input Interface](#).

Steps

1. Go to **Digital IO Control**, and select **Line Selector** from **In 1** to **In 2**.

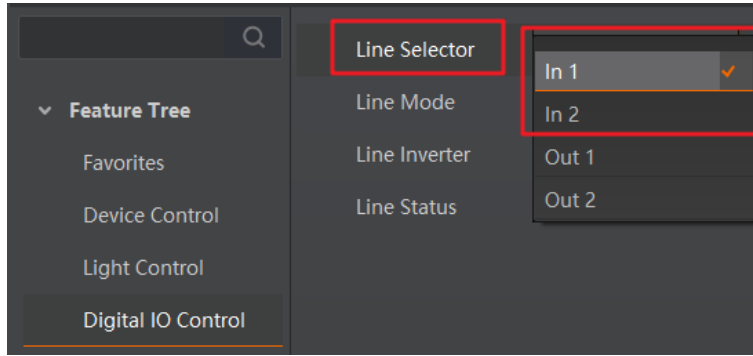

Figure 6-12 Select Line Selector

2. (Optional) Enable **Line Inverter** to invert selected electrical level status of input signals.

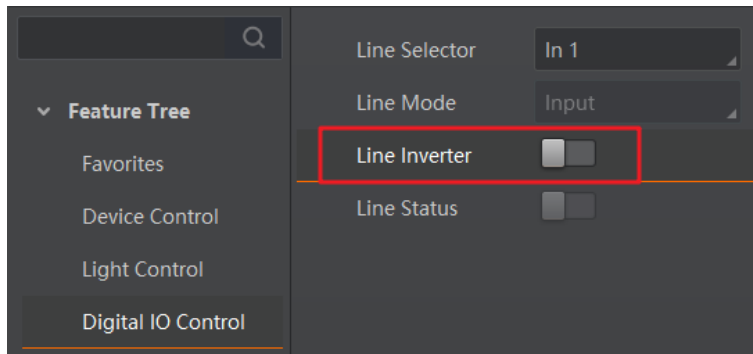

Figure 6-13 Enable Line Inverter

3. (Optional) Set **Line Debounce Time** according to actual demands. The range is between 0 ms to 1000 ms.

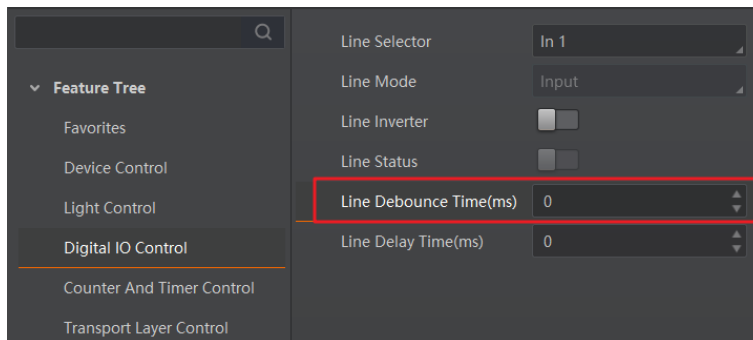

Figure 6-14 Set Line Debounce Time

Note

The parameter of **Line Debounce Time** may differ by device models.

4. (Optional) Set **Line Delay Time** according to actual demands.

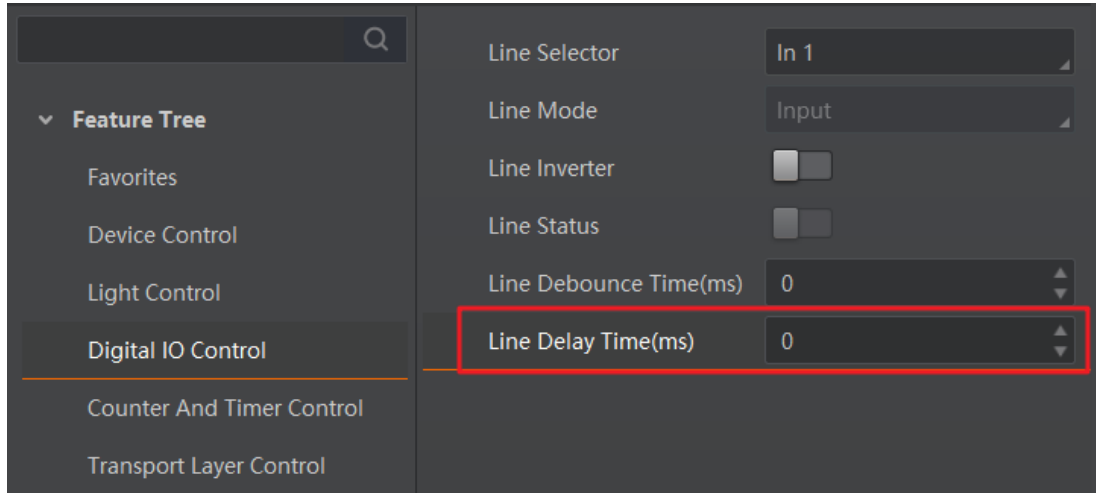

Figure 6-15 Set Line Delay Time

Note

The parameter of **Line Delay Time** may differ by device models.

6.6.2 Set IO Output

The device supports setting multiple output signals, and outputs them after inverting the output level status.

Note

For specific information regarding the I/O output interface and wiring methods, please refer to the section [Trigger Output Interface](#).

Steps

1. Go to **Digital IO Control**, and select **Line Selector** from **Out 1** to **Out 2**.

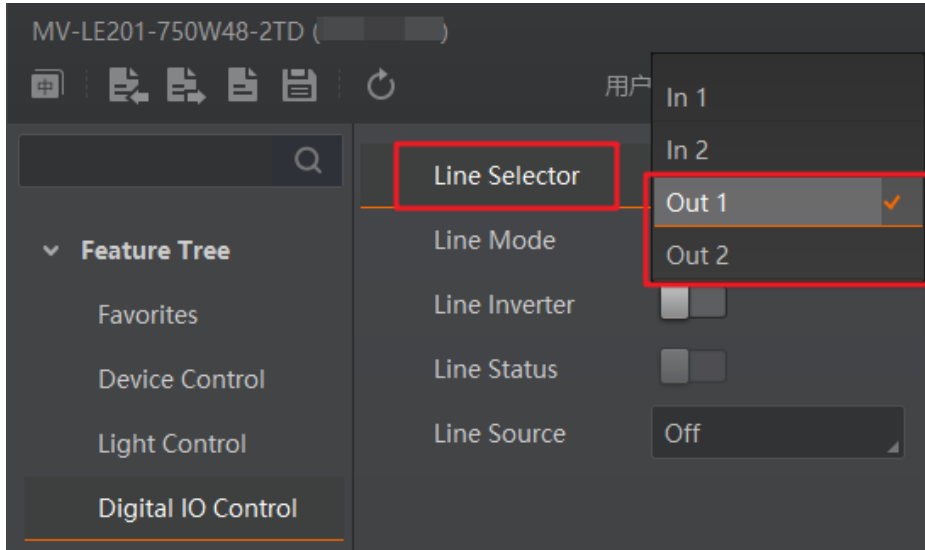

Figure 6-16 Select Line Selector

2. (Optional) Enable **Line Inverter** to invert selected electrical level status of output signals.

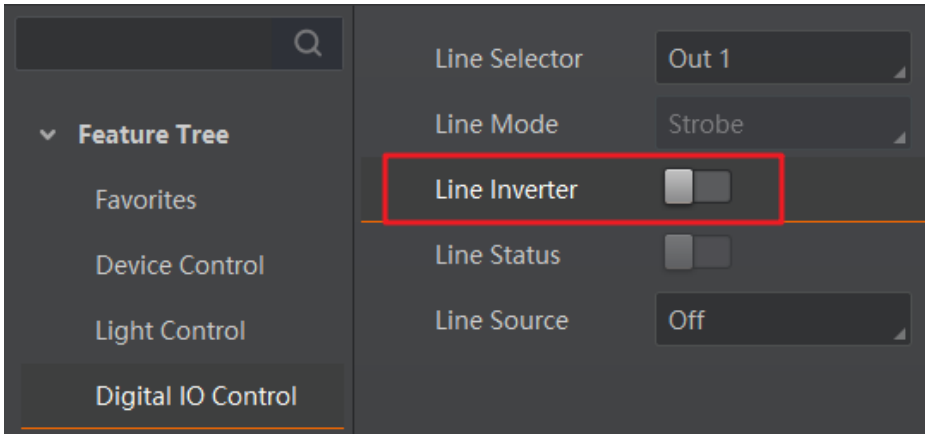

Figure 6-17 Enable Line Inverter

3. Select the signal source of outputted signals in **Line Source**. You can select two input channels (In 1 to In 2), two timer control signals (Timer 1 to Timer 2), and the option to turn off the signal source (Off), as shown in the figure below.

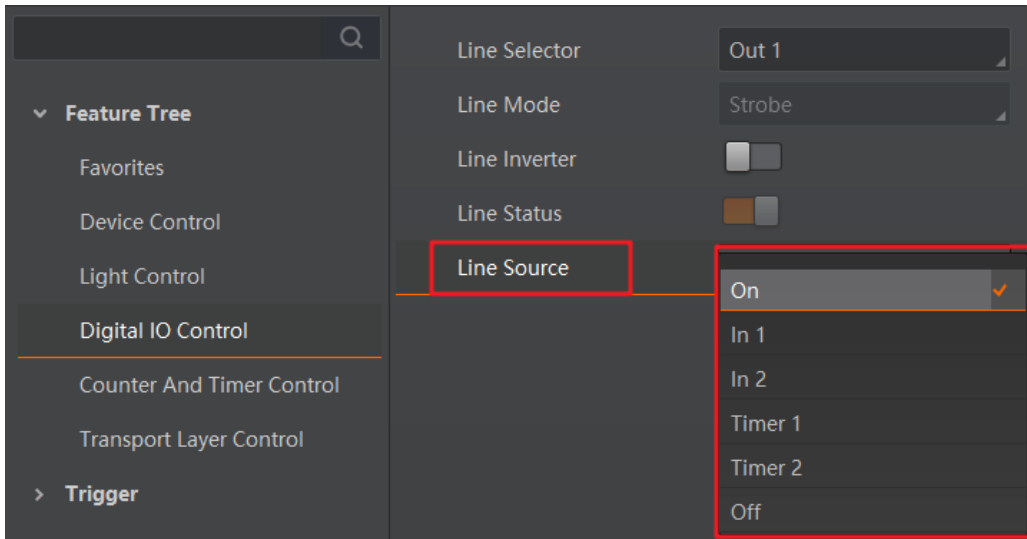

Figure 6-18 Select Line Source

6.7 Set Timer Control

The timer control can output the corresponding signal by setting the high level and low level duration of the timer signal, under the condition of the selected timer mode and corresponding parameters. You can go to **Counter and Timer Control** to set related parameters.

Before You Start

Make sure light sources are connected to the corresponding interfaces and other wirings completed.

Steps

1. Select one timer from **Timer Selector**.

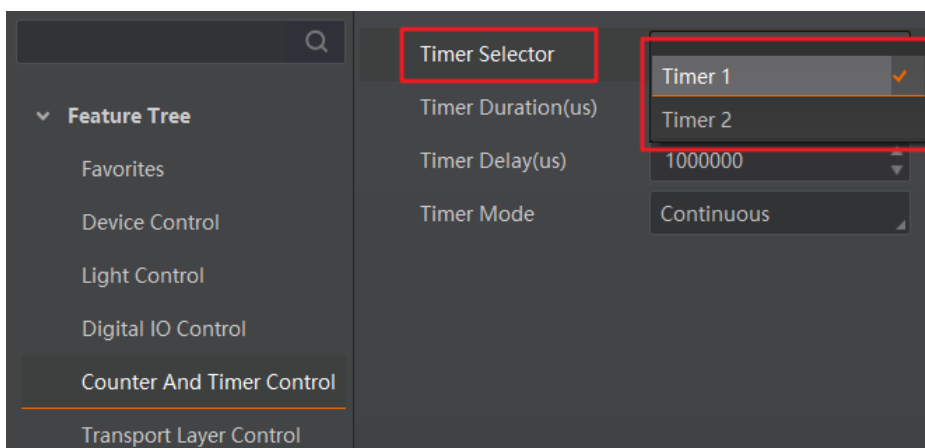

Figure 6-19 Select Timer Selector

2. Set **Timer Duration** and **Timer Delay** according to actual demands. The principle of timer output is shown below.

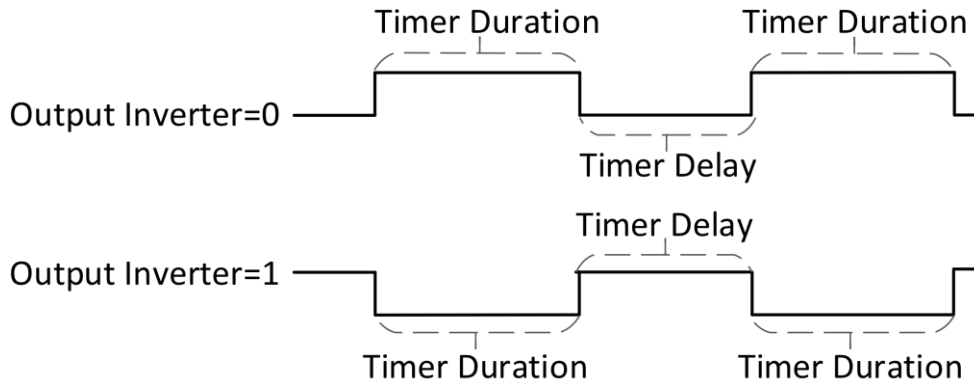

Figure 6-20 Principle of Timer Output

3. Set **Timer Mode** according to actual demands.

- Continuous: The device outputs signals are continuously in accordance with configured **Timer Duration** and **Timer Delay**.
- Burst: If **Burst** is selected as **Timer Mode**, you need to follow steps below to set other parameters.

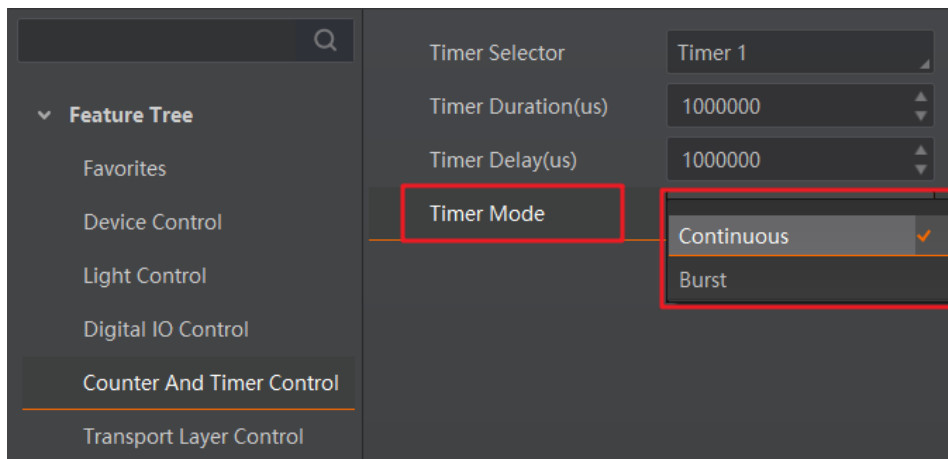

Figure 6-21 Select Timer Mode

4. Set **Timer Burst Count** to configure burst count of the light source.

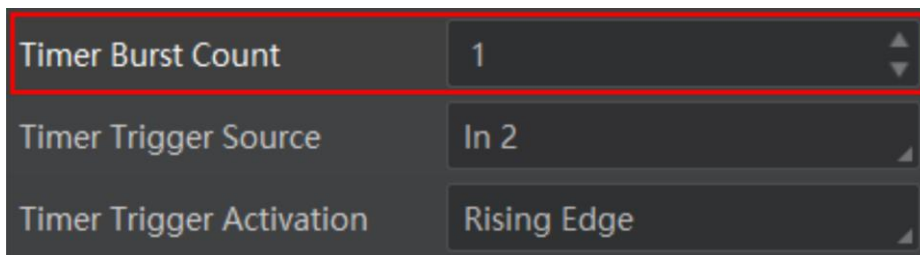

Figure 6-22 Set Timer Burst Count

5. Set **Timer Trigger Source** according to actual demands.

- If **Software** is selected as **Timer Trigger Source**, you can click **Execute** in **Trigger Software** to send trigger signals to the device.

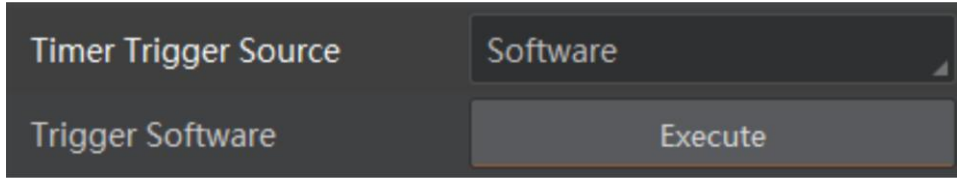

Figure 6-23 Set Software Trigger

- If **In 1** to **In 2** is selected as **Timer Trigger Source**, the external device sends trigger signals to the device, and you can set trigger activation in **Timer Trigger Activation**.

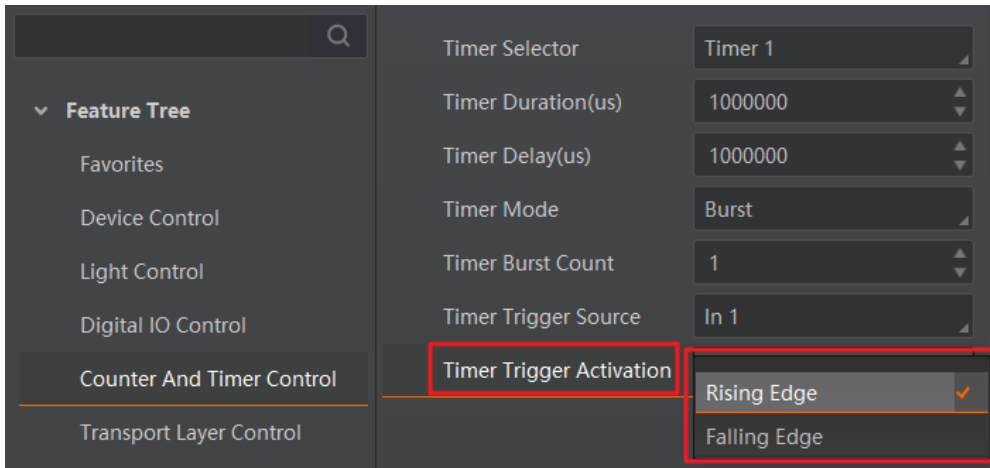



Figure 6-24 Set Hardware Trigger

6.8 View Device Control

You can go to **Device Control** to view the device's information, and detailed parameters are as followed.

Table 6-4 Device Control Parameters

Parameters	Read/Write	Description
Device Vendor Name	Read Only	It is the device's vendor name.
Device Model Name	Read Only	It is the device's model information.
Device Manufacturer Info.	Read Only	It is the device's manufacturer information.
Device Version	Read Only	It is the device's version information.
Device Serial Number	Read Only	It is the device's serial No.
Device User ID	Read/Write	It is the device name and it is empty by default. You can set it according to your preference.

Parameters	Read/Write	Description
		<ul style="list-style-type: none"> • If User ID is empty, the client software displays the device model (serial No.). • If you set it, the client software displays the User ID you set (serial No.).
Maximum Device Response Time	Read Only	It is the device's max. response time. If no response is received within the time, it is considered a device disconnection.
Device Manifest Table Address	Read Only	It is the selected ID of GenICam XML.
Device Uptime(s)	Read Only	It is the period of time when device is powered up.
Device Link Speed (Mbps)	Read Only	It is the device's link speed.
Board Device Type	Read Only	It is the device type.
Device Character Set	Read Only	It is the character set used by the strings of the device.
Device Reset	Read/Write	Click Execute to reset the device.
User Set Save	Read/Write	Click Execute to save the device's parameters.  Note If you do not manually save parameters after configuration, the configured parameters will be automatically saved after 2 minutes.
User Set Reset	Read/Write	Click Execute to reset the device's parameters.

6.9 Update Firmware

You can use the MVS Tool Kit to update the device's firmware.

Note

The MVS Tool Kit is installed by default when you install the MVS client software.

Steps

1. Go to **All** → **Configuration Tool** → **Firmware Upgrade Tool** after running MVS Tool Kit.
2. Click  in the corresponding device interface type like GigE to search devices.

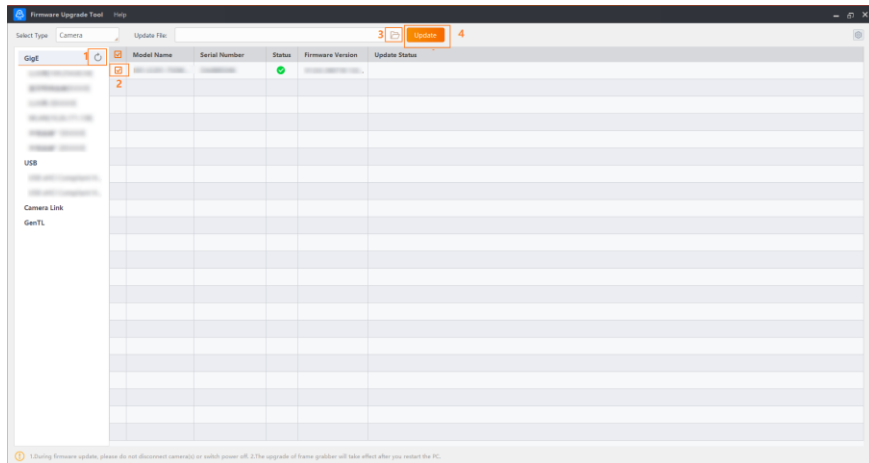



Figure 6-25 Update Firmware

Note

Devices with serial port should be searched in **Serial Port**.

3. Check to select the device you want to update.
 4. Click  to select update files (.dav files) in the local PC.
 5. Click **Update** to start updating.
-

Note

- The device will reboot automatically after updating the firmware.
 - The firmware updating process may take a few minutes, please wait patiently.
 - During firmware updating, do not disconnect the device or switch power off.
-

Chapter 7 Light Controller Configuration Tool

7.1 Main Window

After connecting light controller via network cable or serial port cable, you can use light controller configuration tool to set its parameters. The main window of the light controller configuration tool is shown below.

Note

- Here we take using serial port cable to connect the device to a PC for an example.
- .Net3.5 and SDK runtime library of industrial camera are required when running light controller. You can contact technical support to get SDK runtime library.

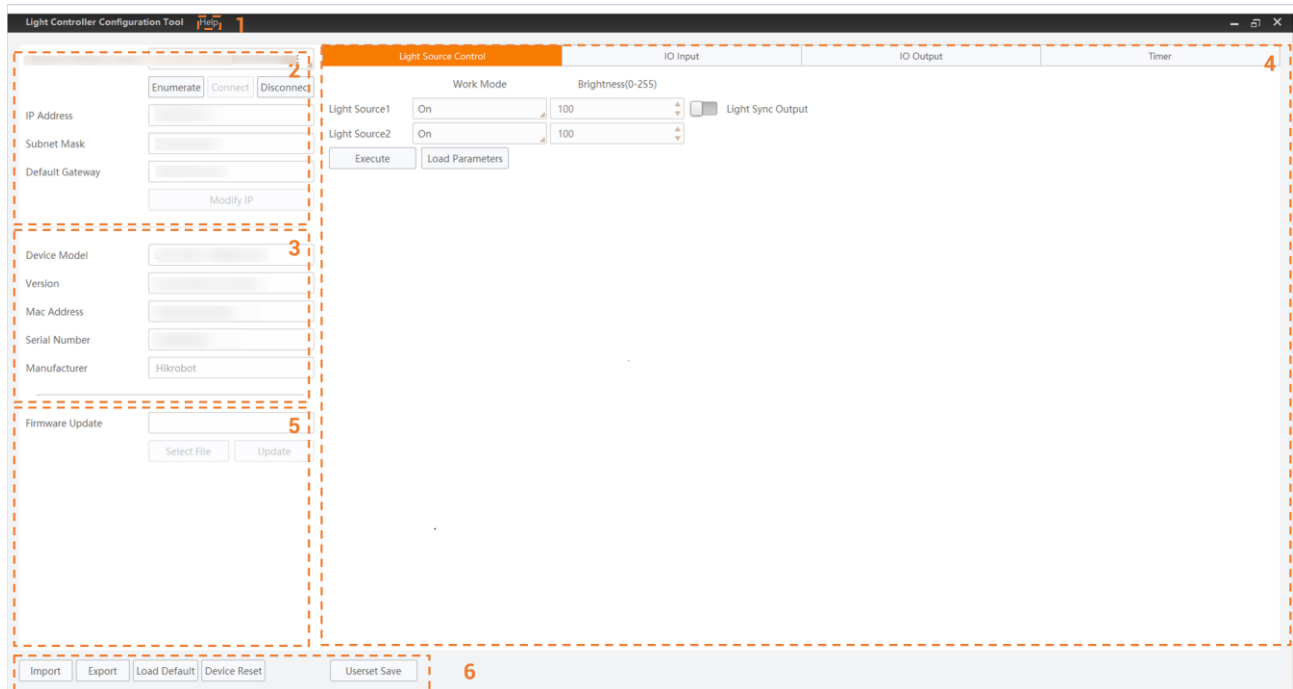



Figure 7-1 Main Window of Light Controller Configuration Tool

Table 7-1 Main Window Description

No.	Area Name	Description
1	Menu	The operation provides assistance, allowing the selection of the tool's language (Chinese and English), and viewing the tool's version information.
2	Serial Port Control	You can connect/disconnect/enumerate device here via light controller after using serial port cable to

No.	Area Name	Description
		connect the device physically. After connection, you can view device information.
3	Device Information	It displays detailed device information.
4	Control Parameters	You can configure the parameters for the device's light source control, IO input, IO output, and timers. For serial devices, you can also set device parameters through the serial command line.
5	Firmware Update	<p>You can update the device's firmware here.</p> <p> Note Disconnect device in Serial Port Control area before updating firmware.</p>
6	Configuration Management	<p>For importing, exporting, resetting, saving the current device parameters, as well as restarting the device or enabling multi-window mode:</p> <ul style="list-style-type: none"> ● Import Parameters: Import external parameter configuration files into the tool. ● Export Parameters: Export parameter configuration files to the local system. ● Reset parameters: The device resets parameters to default ones. ● Restart device: The device restarts. <p> Note If the parameter configuration is completed and not manually saved, the device will automatically save the parameters after 2 minutes.</p>

 **Note**

When running the tool, it requires dependencies on .Net 3.5 and the industrial camera SDK runtime library. If there is a need for the industrial camera SDK runtime library, please contact technical support to obtain it.

7.2 Connect Device via Controller

After using network cable or serial port cable to connect the device physically, you can use digital light controller to connect the device and set related parameters.

The serial port control module connects to the device via the serial port, and after a successful connection, parameter settings are made through the related modules on the

right. The parameter control modules are: light source control, IO input, IO output, timer, and command line.

Before You Start

Use serial port cable to connect the device to a PC via serial port.

Steps

1. Run the digital light controller, and select Serial Port.

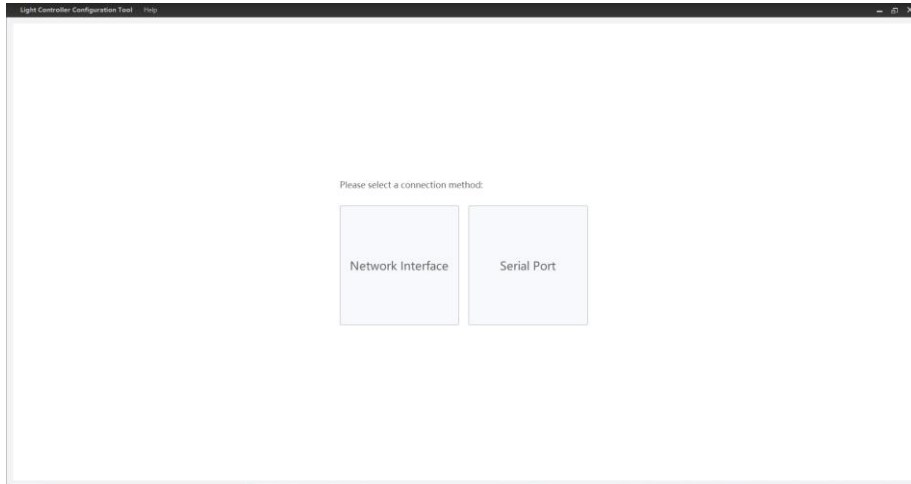

Figure 7-2 Select Serial Port

2. Click **Enumerate**, and select the device according to actual demands.
3. Select **Baud Rate** according to actual demands.
4. Click **Connect**, and the controller will display the device information, and you can set parameters accordingly. Click **Disconnect** to disconnect the device.

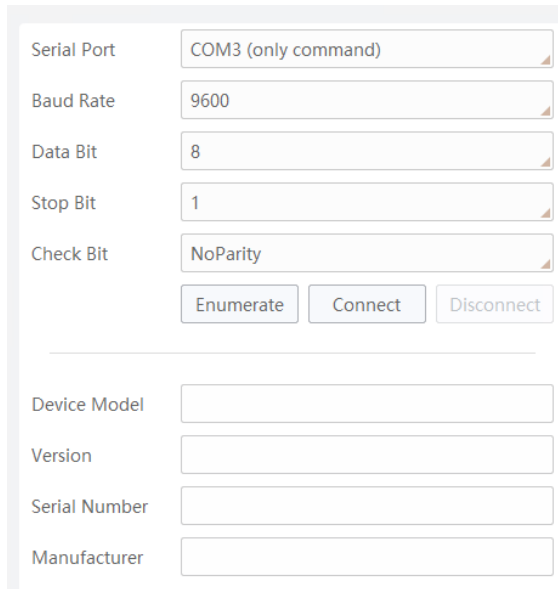

Figure 7-3 Serial Port Connection

7.3 Light Source Control

The device can use the light source control module to set the light source brightness value and working mode, and at the same time, they can obtain the current parameters of the device, as shown in the figure below.

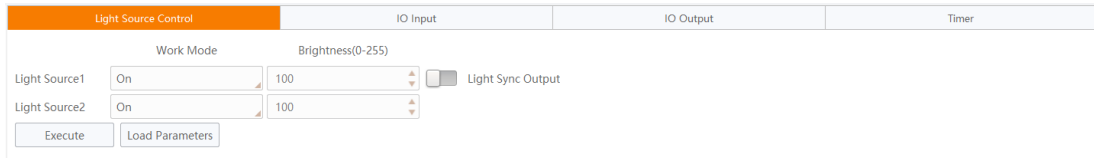

Figure 7-4 Light Source Control

Before You Start

Make sure that related wirings are completed and light source devices are connected.

Steps

1. Click **Load Parameters** to get the current parameters of the light source.
2. Select light source from **Light Source 1** to **Light Source 2** corresponding CH1 to CH2 according to actual demands.
3. Select **Work Mode** according to actual demands.

Table 7-2 Working Mode Description

Working Mode	Description
Solid	The light source is in solid status.
Input 1/2	Use trigger input interface signal (IN 1/2) to control light source output.
Timer 1/2	Use timer 1/2 trigger signals to control light source output.
Off	The light source is turned off.

4. Set **Brightness** according to actual demands, and it ranges from 0 to 255.
5. Click **Execute** to let the device execute configured parameters.
6. (Optional) Check **Light Sync Output** to let the settings of CH 1 channel apply to other light source channels.

7.4 I/O Control Input

The device can set the debounce time and delay time for the input interfaces, obtain the level status of the input interfaces, and simultaneously set the inversion of the current level status through the IO input module, as shown in the figure below.

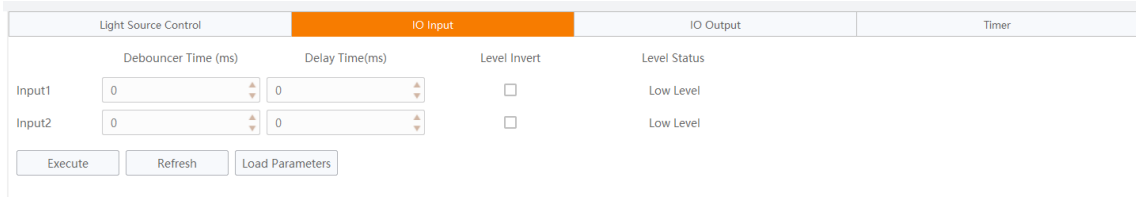

Figure 7-5 I/O Control Input

Before You Start

Make sure that related wirings are completed and light source devices are connected.

Steps

1. Click **Load Parameters** to get the input parameters.
2. Use **Debounce Time** to perform debounce of the trigger input signal source. The value should be between 0 and 1000, and the unit is ms.
3. Use **Delay Time** to set the delay time for the trigger input signal source. The value should be between 0 and 1000, and the unit is ms.
4. Check **Invert** to invert selected electrical level status of input signals.
5. Click **Refresh** to display the electrical level status of input signals, including **High Level** and **Low Level**.
6. Click **Execute** to let the device execute configured parameters.

7.5 I/O Control Output

The device can set the signal source and level inversion for each trigger output port through the IO output module, as shown in the figure below.

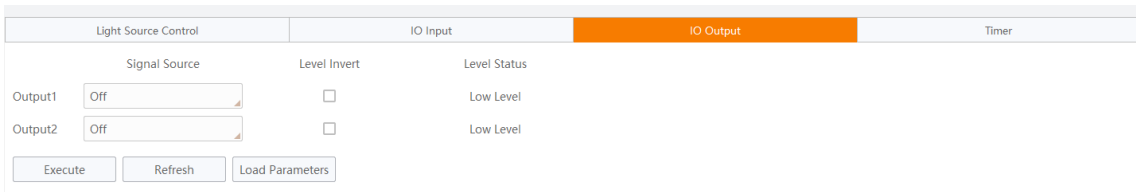

Figure 7-6 I/O Control Output

Before You Start

Make sure that related wirings are completed and light source devices are connected.

Steps

1. Click **Load Parameters** to get the output parameters.
2. Select **Signal Source** of trigger output. The types and descriptions of signal sources are show below.

Table 7-3 Trigger Output Signal Source

Signal Source	Description
Solid	The light source is in solid state.
IN 1/2	Using IN1/2 input signals as the trigger output signal source.
Timer 1/2	Using timer 1/2 signals as the trigger output signal source.
Off	The signal source is in the off state.

3. Check **Invert** to invert selected electrical level status of output signals.
4. Click **Refresh** to display the electrical level status of output signals, including **High Level** and **Low Level**.
5. Click **Execute** to let the device execute configured parameters.

7.6 Timer

The timer acts as an internal clock and provides a continuous square wave based on trigger conditions. When the device' trigger source selects the timer, the device will generate the corresponding trigger square wave according to the configured delay time and pulse width to delay the trigger of the external device.

The device can set parameters such as the trigger mode, trigger source, and trigger edge of the timer signal through the timer module, as shown in the figure below.

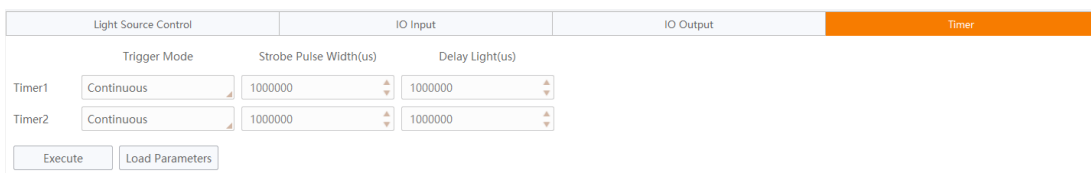

Figure 7-7 Timer Trigger

Before You Start

Make sure that related wirings are completed and light source devices are connected.

Steps

1. Click **Load Parameters** to get the current timer's parameters.
2. Select **Trigger Mode** according to actual demands, including continuous and discontinuous mode.

Note

In the continuous mode, the light source will strobe flash continuously. While in the burst mode, the light source will strobe flash based on specific number.

3. Set **Strobe Pulse Width** (duration of the light source illumination for each strobe cycle) according to actual demands.
 4. Set **Delay Light** (the delay time for the light source to illuminate) according to actual demands.
-

5. When selecting **Burst** mode, the following parameters need to be set.

- **Trigger Source:** It sets the trigger signal source of the timer. For details on the various trigger sources and their meanings, please refer to the table below.

Table 7-4 Trigger Source of Timer

Trigger Source	Description
Software Trigger	By using software triggering, a trigger signal is provided for the timer trigger. When the trigger source is set to software trigger, after clicking execute, a trigger signal can be sent to the light controller by clicking the software trigger button.
Input 1/2	Use IN 1/2 input signal as the trigger signal of the timer.

- **Trigger Activation:** It sets the trigger activation of the timer, including rising edge and falling edge. When the trigger source is set to software trigger, the trigger type parameter is not supported.

- **Trigger Amount:** Set the number of times the light source flashes.

6. Click **Execute** to send the configured parameters to the device and initiate the operation.

7.7 Command Line

When the light controller is connected to the device via a serial port, you can set the device parameters through the serial command line. For more details, please refer to the section [Serial Communication Command List](#).

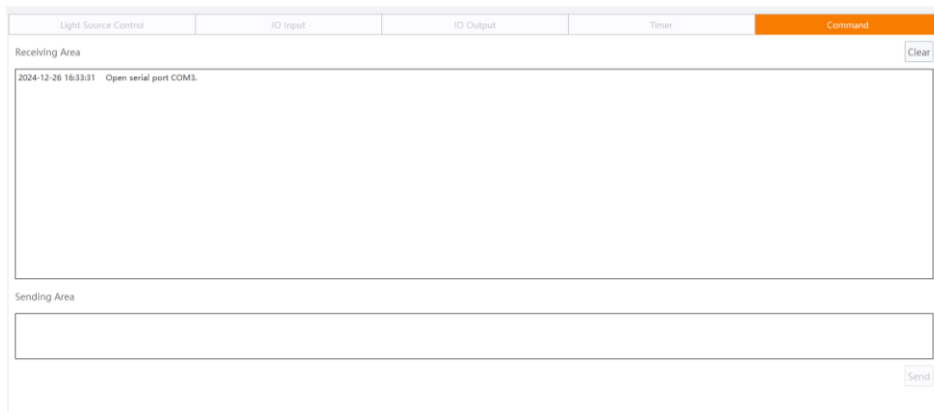

Figure 7-8 Serial Command Line

Before You Start

Connect the light source to the interface and ensure that the cables of the device are correctly connected. For details, please refer to the section [Connect Device](#). The tool has enumerated the spot light controller.

Steps

1. Select the COM port with "only command" in the drop-down serial port, as shown in the figure below.

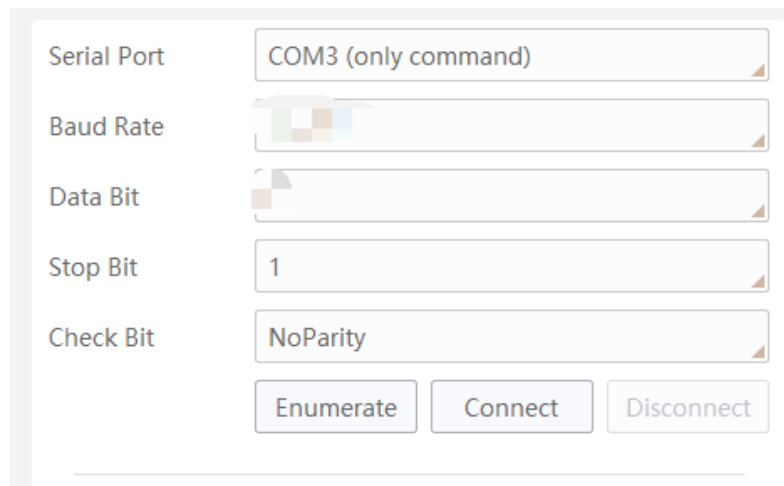

Figure 7-9 Select COM Port

2. Click **Connect**, and a command line module will appear on the right side of the tool's interface.
3. Enter the corresponding serial port command in the send box, and after clicking Send, the receive area will display the corresponding content.
4. (Optional) Click **Clear** in the upper-right corner of the receive area to clear its contents.

7.8 Update Firmware

The device supports updating firmware via the light controller.

Before You Start

Disconnect device in Network Interface/Serial Port Control area before updating firmware.

Steps

1. Click **Select Files** to select firmware package (dav files).
2. Click **Update** to update the firmware.

Firmware Update

Figure 7-10 Update Firmware

 **Note**

The device will restart automatically after updating is completed.

Chapter 8 FAQ (Frequently Asked Question)

8.1 Why PWR indicator on the control panel is unlit?

Table 8-1 Question 1

Possible Cause	Solution
The device is not powered on or the power switch is not pressed.	Check the power wiring, and make sure that the PWR indicator is solid red after powering on the device.

8.2 Why light source devices cannot be turned on?

Table 8-2 Question 2

Possible Cause	Solution
There is no voltage in the external trigger signal.	Check if there is broken circuit, incorrect polarity, etc.
Incorrect external trigger wiring.	Make sure that the light source interface of the light controller corresponds to correct external light source devices.
Incorrect light source work mode setting.	Set the light source mode as solid, and increase the brightness at the same time.

8.3 Why light source devices cannot be triggered?

Table 8-3 Question 3

Possible Cause	Solution
There is no voltage in the external trigger signal.	Check if trigger signal types or wirings are correct.
Incorrect external trigger wiring.	Make sure that the trigger related wirings are correct.
The voltage of the external trigger signal is too low.	Increase the voltage of the trigger signal

8.4 Why light source lights off intermittently?

Table 8-4 Question 4

Possible Cause	Solution
The load is too high and power switch power supply executes overload protection.	Reduce the load on the controller.

Chapter 9 Revision History

Table 9-1 Revision History

Version	Revision Date	Revision Details
V1.0.0	Mar. 12, 2026	Original version.

Appendix A Serial Communication Command List

The serial port information used by the device as follows:

- Communication Protocol: RS-232
- Serial Baud Rate: 115200 bps
- Serial Data Bits: 8
- Serial Stop Bit: 1
- Serial Parity: None

Table A-1 Serial Communication Command List

Function	Start Symbol	Function Identifier	Channel Field	Data Field	End Symbol	Command	Description
Read Brightness	S	L	A to F	-	#	<ul style="list-style-type: none"> ● Send: SLA# ● Return: LA0100 	<ul style="list-style-type: none"> ● Read the brightness of CH1. ● Reading the brightness of CH1 is 100.
						<ul style="list-style-type: none"> ● Send: SLABCD# ● Return: LA0100B0080C0255D0010 	<ul style="list-style-type: none"> ● Read the brightness of CH1 to CH4. ● Reading the brightness of CH1 to CH4 is 100, 80, 255, and 10.
Set Brightness	S	L	A to F	Brightness level: 0000 to 0255	#	<ul style="list-style-type: none"> ● Send: SLA0100# ● Return: LA0100 	<ul style="list-style-type: none"> ● Set the brightness of CH1 to 100. ● Setting the brightness of CH1 to 100 succeeded.
						<ul style="list-style-type: none"> ● Send: SLA0100B0080C0255D0010# ● Return: LA0100B0080C0255D0010 	<ul style="list-style-type: none"> ● Set the brightness of CH1 to CH4 to 100, 80, 255, and 10. ● Setting the brightness of CH1 to CH4 to 100, 80, 255, and 10 succeeded.
Set Continuous/Trigger/Strobe Mode	S	T	A to F	0000/0001/0002 (continuous/trigger/strobe)	#	<ul style="list-style-type: none"> ● Send: ST0000# ● Return: T0000 	<ul style="list-style-type: none"> ● Set continuous mode ● Setting continuous mode succeeds
						<ul style="list-style-type: none"> ● Send: ST0001# ● Return: T0001 	<ul style="list-style-type: none"> ● Set trigger mode ● Setting trigger mode succeeds
						<ul style="list-style-type: none"> ● Send: ST0002# ● Return: T0002 	<ul style="list-style-type: none"> ● Set strobe mode ● Setting strobe mode succeeds
Set On/Off	S	W	A to F	0000/0001 (on/off)	#	<ul style="list-style-type: none"> ● Send: SWA0000# ● Return: WA0000 	<ul style="list-style-type: none"> ● Set the status of CH1 to On. ● Setting the status of CH1 to On succeeded.
						<ul style="list-style-type: none"> ● Send: SWA0001B0000C0001D0001# ● Return: WA0001B0000C0001D0001 	<ul style="list-style-type: none"> ● Set the status of CH1 to CH4 to Off, On, Off, and Off. ● Setting the status of CH1 to CH4 to Off, On, Off, and Off succeeded.
Read Trigger Debounce Time	S	G	A to F	-	#	<ul style="list-style-type: none"> ● Send: SGA# ● Return: GA0001 	<ul style="list-style-type: none"> ● Read the trigger debounce time of CH1. ● Reading the trigger debounce time of CH1 is 1 ms
Set Trigger Debounce Time	S	G	A to F	0000 to 1000 (unit: ms)	#	<ul style="list-style-type: none"> ● Send: SGA0100# ● Return: GA0100 	<ul style="list-style-type: none"> ● Set the trigger debounce time of CH1 to 100 ms. ● Setting the trigger debounce time of CH1 to 100 ms succeeded.

Spot Light Controller User Manual

Function	Start Symbol	Function Identifier	Channel Field	Data Field	End Symbol	Command	Description
Read Trigger Delay Time	S	H	A to F	-	#	<ul style="list-style-type: none"> ● Send: SHA# ● Return: HA0100 	<ul style="list-style-type: none"> ● Read the trigger delay time of CH1. ● Reading the trigger delay time of CH1 is 100 ms
Set Trigger Delay Time	S	H	A to F	0000 to 1000 (unit: ms)	#	<ul style="list-style-type: none"> ● Send: SHA0100# ● Return: HA0100 	<ul style="list-style-type: none"> ● Set the trigger delay time of CH1 to 100 ms. ● Setting the trigger delay time of CH1 to 100 ms succeeded.
Set Trigger Level Inversion	S	I	A to F	0000/0001 (false/true)	#	<ul style="list-style-type: none"> ● Send: SIA0001# ● Return: IA0001 	<ul style="list-style-type: none"> ● Set the trigger level inversion of CH1 to true. ● Setting the trigger level inversion of CH1 to true succeeded.
Read Trigger Level Status	S	J	A to F	-	#	<ul style="list-style-type: none"> ● Send: SJA# ● Return: JA0001 	<ul style="list-style-type: none"> ● Read the trigger level status of CH1. ● Reading the trigger level status of CH1 is high.
Set IO Output Port Level Inversion	S	K	A to F	0000/0001 (false/true)	#	<ul style="list-style-type: none"> ● Send: SKA0001# ● Return: KA0001 	<ul style="list-style-type: none"> ● Set the output port level inversion of CH1 to true. ● Setting the output port level inversion of CH1 to true succeeded.
Set IO Output Port Signal Source	S	M	A to F	0000/0001/0002/0003 (on/in/timer/off)	#	<ul style="list-style-type: none"> ● Send: SMA0002# ● Return: MA0002 	<ul style="list-style-type: none"> ● Set the IO output port signal source of CH1 to timer. ● Setting the IO output port signal source of CH1 to timer succeeded.
Read IO Output Port Level Status	S	N	A to F	-	#	<ul style="list-style-type: none"> ● Send: SNA# ● Return: NA0001 	<ul style="list-style-type: none"> ● Read the IO output port level status of CH1. ● Reading the IO output port level status of CH1 is high.
Read Timer Duration	S	O	A to F	-	#	<ul style="list-style-type: none"> ● Send: SOA# ● Return: OA0600 	<ul style="list-style-type: none"> ● Read the timer duration of CH1. ● Reading the timer duration of CH1 is 600 μs.
Set Timer Duration	S	O	A to F	0600 to 30000000 (unit: μs)	#	<ul style="list-style-type: none"> ● Send: SOA0600# ● Return: OA0600 	<ul style="list-style-type: none"> ● Set the timer duration of CH1 to 600 μs . ● Setting the timer duration of CH1 to 600 μs succeeded.
Read Timer Delay Time	S	P	A to F	-	#	<ul style="list-style-type: none"> ● Send: SPA# ● Return: PA0600 	<ul style="list-style-type: none"> ● Read the timer delay time of CH1. ● Reading the timer delay time of CH1 is 600 μs.
						<ul style="list-style-type: none"> ● Send: SPABCD# ● Return: PA0999B0888C0777D0666 	<ul style="list-style-type: none"> ● Read the timer delay time of CH1 to CH4. ● Reading the timer delay time of CH1 to CH4 is 999 μs, 888 μs, 777 μs, 600 μs.
Set Timer Delay Time	S	P	A to F	0600 to 30000000 (unit: μs)	#	<ul style="list-style-type: none"> ● Send: SPA0600# ● Return: PA0600 	<ul style="list-style-type: none"> ● Set the timer delay time of CH1. ● Setting the timer delay time of CH1 to 600 μs succeeded.
						<ul style="list-style-type: none"> ● Send: SPA0999B0888C0777D0666# 	<ul style="list-style-type: none"> ● Set the timer delay time of CH1 to CH4 to 999 μs, 888 μs, 777 μs, 666 μs.

Spot Light Controller User Manual

Function	Start Symbol	Function Identifier	Channel Field	Data Field	End Symbol	Command	Description
						<ul style="list-style-type: none"> Return: PA0999B0888C0777D0666 	<ul style="list-style-type: none"> Setting the timer delay time of CH1 to CH4 to 999 μs, 888 μs, 777 μs, 666 μs succeeded.
Set Count Value of the Timer under Burst Mode	S	R	A to F	0001 to 1023	#	<ul style="list-style-type: none"> Send: SRA0100# Return: RA0100 	<ul style="list-style-type: none"> Set the count value of the timer under burst mode of CH1 Setting the count value of the timer under burst mode of CH1 to 100 succeeded.
Set the Trigger Source of the Timer under Burst Mode	S	V	A to F	0000/0001 (Software/in)	#	<ul style="list-style-type: none"> Send: SVA0001# Return: VA0001 	<ul style="list-style-type: none"> Set the trigger source of the timer under burst mode for CH1 to in. Setting the trigger source of the timer under burst mode for CH1 to in succeeded.
Set Trigger Source of the Timer under Burst Mode to Trigger Once When it is Set to Software Trigger	S	X	A to F	0001	#	<ul style="list-style-type: none"> Send: SXA0001# Return: XA0001 	<ul style="list-style-type: none"> Set the trigger source of the timer under burst mode for CH1 to trigger once when it is set to software trigger. Setting the trigger source of the timer under burst mode for CH1 to trigger once when it is set to software trigger succeeded.
Set the Trigger Edge When the Trigger Source of the Timer under Burst Mode is an External Signal	S	Y	A to F	0000/0001 (Rising Edge/Falling Edge)	#	<ul style="list-style-type: none"> Send: SYA0001# Return: YA0001 	<ul style="list-style-type: none"> Set the trigger edge to Falling Edge when the trigger source of the timer under burst mode is an external signal. Setting the trigger edge to Falling Edge when the trigger source of the timer under burst mode is an external signal succeeded.
Save User Set/Restore Default	S	U	-	0000/0001 (save/reset)	#	<ul style="list-style-type: none"> Send: SU0000# Return: U0000 	<ul style="list-style-type: none"> Save user parameters. Saving user parameters succeeded.
						<ul style="list-style-type: none"> Send: SU0001# Return: U0001 	<ul style="list-style-type: none"> Restore user parameters to default. Restoring user parameters to default succeeded.
Read the Number of Light Source Channels	S	Z	-	000	#	<ul style="list-style-type: none"> Send: SZ0000# Return: Z0004 	<ul style="list-style-type: none"> Read the number of light source channels. Reading the number of light source channels for controller is four.
Read/Set Error Return	-	L/P/T/W/ U/G/H/I/ J/K/M/N /O/Q/R /V/X/Y/Z	A to F or Empty	XXXX	-	Return: LAXXXX	An error occurs or invalid parameters are sent while searching/setting the brightness parameter of CH1.
						Return: PAXXXX	An error occurs or invalid parameters are sent while searching/setting the pulse width time parameter of CH1.
						Return: TAXXXX	An error occurs or invalid parameters are sent while searching/setting Solid/Trigger mode.
						Return: WAXXXX	An error occurs or invalid parameters are sent while searching/setting On/Off status of CH1.
						Return: UAXXXX	An error occurs or invalid parameters are sent while saving parameters or restoring default.
						Return: GAXXXX	An error occurs or invalid parameters are sent while setting the trigger debounce time of CH1.
						Return: HAXXXX	An error occurs or invalid parameters are sent while reading trigger debounce time of CH1.
Return: IAXXXX	An error occurs or invalid parameters are sent while setting the trigger level inversion of CH1.						

Spot Light Controller User Manual

Function	Start Symbol	Function Identifier	Channel Field	Data Field	End Symbol	Command	Description
						Return: JAXXXX	An error occurs or invalid parameters are sent while reading the trigger level inversion of CH1.
						Return: KAXXXX	An error occurs or invalid parameters are sent while setting the output port level inversion of CH1.
						Return: MAXXXX	An error occurs or invalid parameters are sent while setting the output port signal source of CH1.
						Return: NAXXXX	An error occurs or invalid parameters are sent while reading the output port level inversion of CH1.
						Return: OAXXXX	An error occurs or invalid parameters are sent while reading/setting the timer duration of CH1.
						Return: RAXXXX	An error occurs or invalid parameters are sent while setting the count value of the timer under burst mode of CH1.
						Return: VAXXXX	An error occurs or invalid parameters are sent while setting the trigger source of the timer under burst mode for CH1.
Read/Set Error Return	--	L/P/T/W/ U/G/H/I/ J/K/M/N /O/Q/R/V /X/Y/Z	A to F or Empty	XXXX	--	Return: XAXXXX	An error occurs or invalid parameters are sent while setting the trigger source of the timer under burst mode for CH1 to trigger once when it is set to software trigger.
						Return: YAXXXX	An error occurs or invalid parameters are sent while setting the trigger edge when the trigger source of the timer under burst mode is in.
						Return: ZAXXXX	An error occurs or invalid parameters are sent while reading the number of light source channels.

 **Note**

A to F represents CH1 to CH6.



HIKROBOT

SHAPE OUR FUTURE INTELLIGENTLY

Hikrobot Co., Ltd.

Tel: 400-989-7998

Website: <https://en.hikrobotics.com/>

UD45625B