

MV-EQ3200-05P V2.0

3D Laser Profile Sensor



Introduction

With built-in high-accuracy algorithm, image process algorithm of wide dynamic range, and data integration algorithm, MV-EQ3200-05P V2.0 can output high accurate 3D point cloud data in real-time by combining high frame rate chip and accurate laser control. With compact structure, high integration, and easy operation, it is widely applied into consumer electronics, electronics manufacturing, automobile, etc.

Available Model

- MV-EQ3200-05P V2.0

Applicable Industry

Consumer electronics, electronics manufacturing, automobile, etc.

Dimension

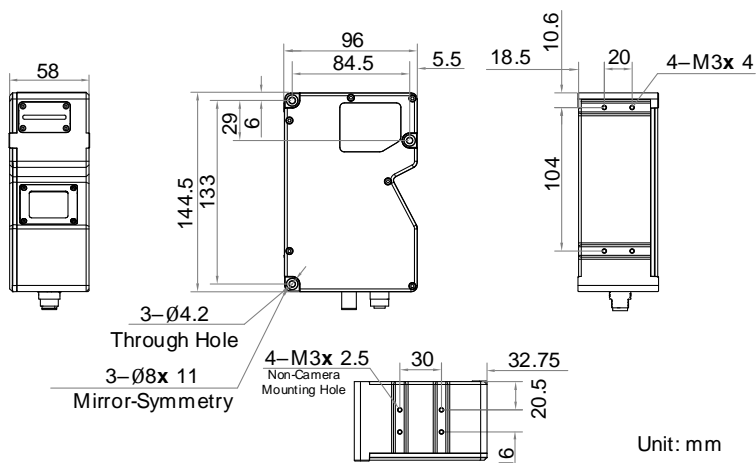

Key Feature

- Built-in high-accuracy algorithm and accuracy is up to submicron level.
- Adopts high frame rate chip with 23.9 kHz scan frame rate.
- Supports multiple exposure modes with good robustness.
- Adopts multiple-frame integration technology to provide complete profiles.
- Provides multiple filter modes with stable data.
- Supports ROI selection and auto setting for easier operation.

Measurement Range Diagram

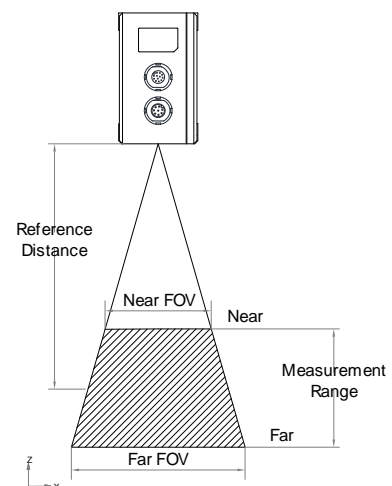

Specification

Model	MV-EQ3200-05P V2.0
Parameter	3D Laser Profile Sensor
Performance	
Data points/profile	3200
Reference distance	120 mm
Measurement range (Z-axis)	80 mm
Measurement range (X-axis)	58 mm @ near field of view 76.5 mm @ reference distance 95 mm @ far field of view
Resolution (Z-axis)	3.66 μm to 8.36 μm
Repeatability (Z-axis)*	1.48 μm @ data that sensor tests gauge block on optical platform
Linearity Z-axis (±% of MR)	0.01
Profile data interval	18.2 μm to 31.7 μm
Scan frame rate	1.7 kHz to 23.9 kHz (high frame rate mode)
Data output	Original image, profile data, depth image, brightness image
Trigger mode	Software trigger, hardware trigger (differential encoder)
Laser safety class	Class 3R
Wavelength	405 nm
Electrical feature	
Data interface	Gigabit Ethernet (1000 Mbit/s), compatible with Fast Ethernet (100 Mbit/s)
Digital I/O	12-pin M12 interface provides power and I/O, including opto-isolated input × 2 (Line 0/9), differential input × 2 (Line 3/6), and differential output × 1 (Line 1)
Power supply	24 VDC
Power consumption	Typ. 15.2 W @ 24 VDC
Mechanical	
Dimension	144.5 mm × 96 mm × 58 mm (5.7" × 3.8" × 2.3")
Weight	Approx. 950 g (2.1 lb.)
Ingress protection	IP67
Temperature	Working temperature: 0 °C to 45 °C (32 °F to 113 °F) Storage temperature: -30 °C to 80 °C (-22 °F to 176 °F)
Humidity	20% RH to 85% RH (no condensation)
General	
Client software	3DMVS, VM3D, or third-party software
Operating system	32/64-bit Windows 7/10, 64-bit Windows 11 (8 GB memory and above, and i5 CPU recommended)

*This data is obtained via testing gauge blocks in a laboratory, and it is an average from 4096 tests.