

MV-DP4430-03P

3D Laser Profile Sensor



Introduction

With high-speed, high-resolution, and large-pixel element image chips, built-in high-accuracy algorithm, image process algorithm of wide dynamic range as well as data integration algorithm, MV-DP4430-03P can output high accurate 3D point cloud data in real-time by combining high frame rate chip and accurate laser control. With compact structure, high integration, and easy operation, it is widely applied into consumer electronics, electronics manufacturing, automobile, etc.

Available Model

MV-DP4430-03P

Applicable Industry

Consumer electronics, electronics manufacturing, automobile, etc.

Dimension

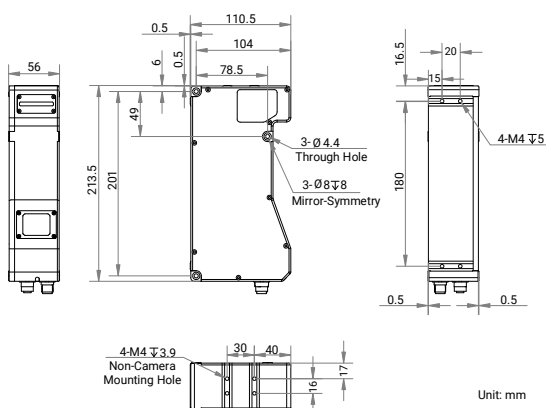

Key Features

- Adopts high-speed, high-resolution, and large-pixel element image chips.
- Adopts FPGA hardware with 49 KHz scan frame rate.
- Provides customized large iris lens and ultra-uniform laser optical solution.
- Adopts ultra-high subpixel algorithm and accuracy is up to submicron level.
- Supports multiple exposure modes with good robustness.
- Adopts multiple-frame integration technology to provide complete profiles.
- Provides multiple filter modes with stable data.
- Adopts integrated design for easy installation and debugging.

Measurement Range Diagram

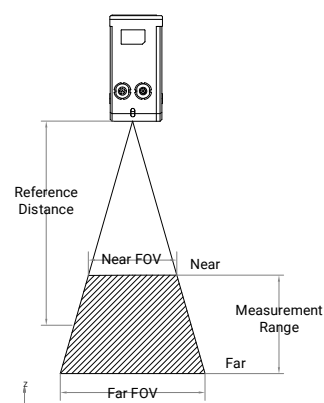

Specification

Model		MV-DP4430-03P
Parameter	3D Laser Profile Sensor	
Performance		
Data points/profile	4080	
Reference distance	430 mm	
Measurement range (Z-axis)	340 mm	
Measurement range (X-axis)	153 mm @ near field of view 241 mm @ reference distance 329 mm @ far field of view	
Resolution (Z-axis)	8.4 μm to 35.5 μm	
Repeatability (Z-axis)*	2.27 μm @ data that sensor tests gauge block on optical platform	
Linearity Z-axis (±% of MR)	0.01	
Profile data interval	35.7 μm to 85.4 μm	
Scan frame rate	2.5 kHz (within max. measurement range), max. 49 kHz (in ROI mode)	
Data output	Profile data, depth image, brightness image	
Trigger mode	Software trigger, hardware trigger (differential encoder)	
Wavelength	650 nm	
Laser safety class	Class 3R	
Electrical feature		
Data interface	Gigabit Ethernet (1000 Mbit/s), compatible with Fast Ethernet (100 Mbit/s)	
Digital I/O	12-pin M12 interface provides power and I/O, including differential input × 3 (Line 0/3/6), differential output × 1 (Line 1), and RS-232 × 1	
Power supply	24 VDC	
Power consumption	Typ. 20 W @ 24 VDC	
Mechanical		
Dimension	213.5 mm × 110.5 mm × 56 mm (8.4" × 4.4" × 2.2")	
Weight	Approx. 1296 g (2.9 lb.)	
Ingress protection	IP67	
Temperature	Working temperature: 0 °C to 45 °C (32 °F to 113 °F) Storage temperature: -30 °C to 80 °C (-22 °F to 176 °F)	
Humidity	20% RH to 85% RH (no condensation)	
General		
Client software	3DMVS (V3.1.0 and above), VM3D, or third-party software	
Operating system	32/64-bit Windows 7/10, 64-bit Windows 11 (8 GB memory and above, and i5 CPU recommended)	

*This data is obtained via testing gauge blocks in a laboratory, and it is an average from 4096 tests.