

MV-DP3062-01P

3D Laser Profile Sensor



Introduction

With built-in high-accuracy algorithm, image process algorithm of wide dynamic range, and data integration algorithm, MV-DP3062-01P can output high accurate 3D point cloud data in real-time by combining high frame rate chip and accurate laser control. With compact structure, high integration, and easy operation, it is widely applied into consumer electronics, electronics manufacturing, automobile, etc.

Available Model

- MV-DP3062-01P
- MV-DP3062-01P V2.0

Applicable Industry

Consumer electronics, electronics manufacturing, automobile, etc.

Dimension

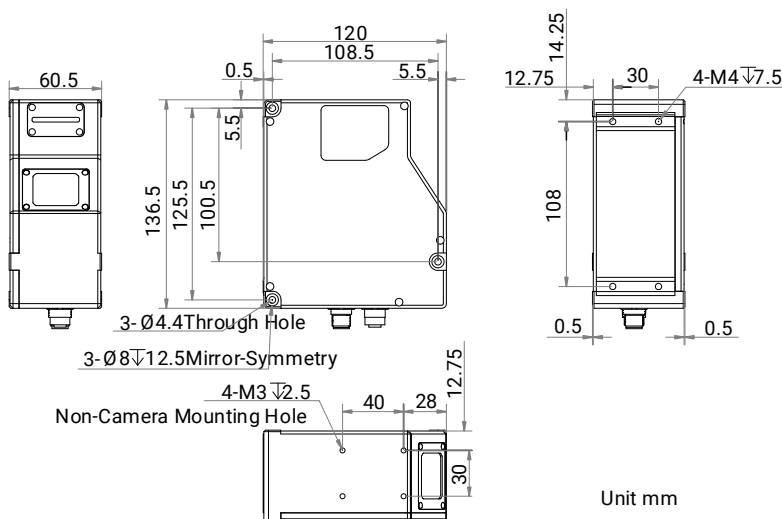

Key Feature

- Built-in high-accuracy algorithm and accuracy is up to submicron level.
- Adopts high frame rate chip with 46.7 kHz scan frame rate.
- Supports multiple exposure modes with good robustness.
- Adopts multiple-frame integration technology to provide complete profiles.
- Provides multiple filter modes with stable data.
- Supports ROI selection and auto setting for easier operation.

Measurement Range Diagram

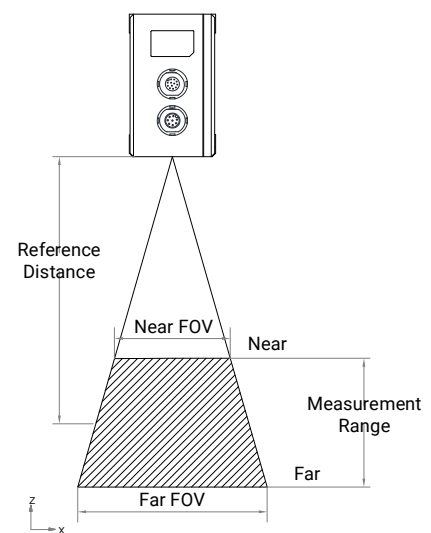

Specification

	Model	MV-DP3062-01P	MV-DP3062-01P V2.0
Parameter	3D Laser Profile Sensor		
Performance			
Data points/profile	3200		
Reference distance	61.5 mm		
Measurement range (Z-axis)	10 mm	11 mm	
Measurement range (X-axis)	16.6 mm @ near field of view 17.8 mm @ reference distance 19 mm @ far field of view	18 mm @ near field of view 19 mm @ reference distance 20 mm @ far field of view	
Resolution (Z-axis)	0.5 μm to 0.8 μm	0.94 μm to 1.22 μm	
Repeatability (Z-axis)*	0.1 μm @ data that sensor tests gauge block on optical platform	0.30 μm @ data that sensor tests gauge block on optical platform	
Linearity Z-axis (±% of MR)	0.01		
Profile data interval	5.2 μm to 5.9 μm	5.5 μm to 6.5 μm	
Scan frame rate	1.3 kHz (within max. measurement range), max. 19 kHz (in ROI mode)	3.4 kHz to 46.7 kHz (high frame rate mode)	
Data output	Profile data, depth image, brightness image		
Trigger mode	Software trigger, hardware trigger (differential encoder)		
Laser safety class	Class 3B		
Wavelength	405 nm		
Electrical feature			
Data interface	Gigabit Ethernet (1000 Mbit/s), compatible with Fast Ethernet (100 Mbit/s)		
Digital I/O	12-pin M12 interface provides power and I/O, including differential input × 3 (Line 0/3/6), differential output × 1 (Line 1), and RS-232 × 1	12-pin M12 interface provides power and I/O, including opto-isolated input × 2 (Line 0/9), differential input × 2 (Line 3/6), and differential output × 1 (Line 1)	
Power supply	24 VDC		
Power consumption	Typ. 13.8 W @ 24 VDC	Typ. 17.2 W @ 24 VDC	
Mechanical			
Dimension	136.5 mm × 120 mm × 60.5 mm (5.4" × 4.7" × 2.4")		
Weight	Approx. 1080 g (2.4 lb.)		
Ingress protection	IP67		
Temperature	Working temperature: 0 °C to 45 °C (32 °F to 113 °F) Storage temperature: -30 °C to 80 °C (-22 °F to 176 °F)		
Humidity	20% RH to 85% RH (no condensation)		
General			
Client software	3DMVS, VM3D, or third-party software		
Operating system	32/64-bit Windows 7/10, 64-bit Windows 11 (8 GB memory and above, and i5 CPU recommended)		

*This data is obtained via testing gauge blocks in a laboratory, and it is an average from 4096 tests.