

Hikrobot Co., Ltd.

3D Laser Profile Sensor V2.0

User Manual

HIKROBOT

Legal Information

© Hangzhou Hikrobot Co., Ltd. All rights reserved.

About this Document

This Document includes instructions for using and managing the Product. Pictures, charts, images and all other information hereinafter are for description and explanation only. The information contained in the Document is subject to change, without notice, due to firmware updates or other reasons. Please find the latest version in the company website (<https://en.hikrobotics.com/>). Unless otherwise agreed, Hangzhou Hikrobot Co., Ltd. or its affiliates (hereinafter referred to as "Hikrobot") makes no warranties, express or implied. Please use the Document with the guidance and assistance of professionals trained in supporting the Product.

Acknowledgment of Intellectual Property Rights

- Hikrobot owns the copyrights and/or patents related to the technology embodied in the Products described in this Document, which may include licenses obtained from third parties. Any part of the Document, including text, pictures, graphics, etc., belongs to Hikrobot. No part of this Document may be excerpted, copied, translated, or modified in whole or in part by any means without written permission.
- **HIKROBOT** and other Hikrobot's trademarks and logos are the properties of Hikrobot in various jurisdictions. Other trademarks and logos mentioned are the properties of their respective owners.

LEGAL DISCLAIMER

TO THE MAXIMUM EXTENT PERMITTED BY APPLICABLE LAW, THIS MANUAL AND THE PRODUCT DESCRIBED, WITH ITS HARDWARE, SOFTWARE AND FIRMWARE, ARE PROVIDED "AS IS" AND "WITH ALL FAULTS AND ERRORS". HIKROBOT MAKES NO WARRANTIES, EXPRESS OR IMPLIED, INCLUDING WITHOUT LIMITATION, MERCHANTABILITY, SATISFACTORY QUALITY, OR FITNESS FOR A PARTICULAR PURPOSE. THE USE OF THE PRODUCT BY YOU IS AT YOUR OWN RISK. IN NO EVENT WILL HIKROBOT BE LIABLE TO YOU FOR ANY SPECIAL, CONSEQUENTIAL, INCIDENTAL, OR INDIRECT DAMAGES, INCLUDING, AMONG OTHERS, DAMAGES FOR LOSS OF BUSINESS PROFITS, BUSINESS INTERRUPTION, OR LOSS OF DATA, CORRUPTION OF SYSTEMS, OR LOSS OF DOCUMENTATION, WHETHER BASED ON BREACH OF CONTRACT, TORT (INCLUDING NEGLIGENCE), PRODUCT LIABILITY, OR OTHERWISE, IN CONNECTION WITH THE USE OF THE PRODUCT, EVEN IF HIKROBOT HAS BEEN ADVISED OF THE POSSIBILITY OF SUCH DAMAGES OR LOSS.

YOU ACKNOWLEDGE THAT THE NATURE OF INTERNET PROVIDES FOR INHERENT SECURITY RISKS, AND HIKROBOT SHALL NOT TAKE ANY RESPONSIBILITIES FOR ABNORMAL OPERATION, PRIVACY LEAKAGE OR OTHER DAMAGES RESULTING FROM CYBER-ATTACK, HACKER ATTACK, VIRUS INFECTION, OR OTHER INTERNET SECURITY RISKS; HOWEVER, HIKROBOT WILL PROVIDE TIMELY TECHNICAL SUPPORT IF REQUIRED.

YOU AGREE TO USE THIS PRODUCT IN COMPLIANCE WITH ALL APPLICABLE LAWS, AND

YOU ARE SOLELY RESPONSIBLE FOR ENSURING THAT YOUR USE CONFORMS TO THE APPLICABLE LAW. ESPECIALLY, YOU ARE RESPONSIBLE, FOR USING THIS PRODUCT IN A MANNER THAT DOES NOT INFRINGE ON THE RIGHTS OF THIRD PARTIES, INCLUDING WITHOUT LIMITATION, RIGHTS OF PUBLICITY, INTELLECTUAL PROPERTY RIGHTS, OR DATA PROTECTION AND OTHER PRIVACY RIGHTS. YOU SHALL NOT USE THIS PRODUCT FOR ANY PROHIBITED END-USES, INCLUDING THE DEVELOPMENT OR PRODUCTION OF WEAPONS OF MASS DESTRUCTION, THE DEVELOPMENT OR PRODUCTION OF CHEMICAL OR BIOLOGICAL WEAPONS, ANY ACTIVITIES IN THE CONTEXT RELATED TO ANY NUCLEAR EXPLOSIVE OR UNSAFE NUCLEAR FUEL-CYCLE, OR IN SUPPORT OF HUMAN RIGHTS ABUSES.

THE PERFORMANCE DATA IN THIS PUBLICATION IS BASED ON HIKROBOT'S INTERNAL RESEARCH/EVALUATION. ACTUAL DATA MAY VARY DEPENDING ON SPECIFIC CONFIGURATIONS AND OPERATING CONDITIONS AND HIKROBOT SHALL NOT BEAR THE CONSEQUENCES ARISING THEREFROM.

IN THE EVENT OF ANY CONFLICTS BETWEEN THIS MANUAL AND THE APPLICABLE LAW, THE LATTER PREVAILS.

Regulatory Information

Note

These clauses apply only to the products bearing the corresponding mark or information.

EU Conformity Statement



This product and - if applicable - the supplied accessories too are marked with "CE" and comply therefore with the applicable harmonized European standards listed under the Directive 2014/30/EU(EMCD), Directive 2001/95/EC(GPSD) and Directive 2011/65/EU(RoHS).



2012/19/EU (WEEE directive): Products marked with this symbol cannot be disposed of as unsorted municipal waste in the European Union. For proper recycling, return this product to your local supplier upon the purchase of equivalent new equipment, or dispose of it at designated collection points. For more information see: <http://www.recyclethis.info>



Regulation (EU) 2023/1542(Battery Regulation): This product contains a battery and it is in conformity with the Regulation (EU) 2023/1542. The battery cannot be disposed of as unsorted municipal waste in the European Union. See the product documentation for specific battery information. The battery is marked with this symbol, which may include lettering to indicate cadmium (Cd), or lead (Pb). For proper recycling, return the battery to your supplier or to a designated collection point. For more information see: www.recyclethis.info.

This is a class A product. In a domestic environment this product may cause radio interference in which case the user may be required to take adequate measures.



KC Mark Certification

Class A: The device is advised to note that as a seller or a business user (Class A) Devices and intended for use outside the Home area.

A급 기기: 이 기기는 업무용(A급) 전자파적합기기로서 판매자 또는 사용자는 이 점을 주의하시기바라며, 가정 외의 지역에서 사용하는 것을 목적으로 합니다.

Symbol Conventions

The symbols that may be found in this document are defined as follows.

Symbol	Description
 Danger	Indicates a hazard with a high level of risk, which if not avoided, will result in death or serious injury.
 Caution	Indicates a potentially hazardous situation which, if not avoided, could result in equipment damage, data loss, performance degradation, or unexpected results.
 Note	Provides additional information to emphasize or supplement important points of the main text.

Available Model

This manual is applicable to the 3D Laser Profile Sensor (DP4000 series devices, DP2000 V2.0 series devices, and DP3000 V2.0 series devices).

Contact Information

Hangzhou Hikrobot Co., Ltd.

E-mail: global.support@hikrobotics.com

Website: <https://en.hikrobotics.com/>

Contents

Chapter 1 Safety Instruction	1
1.1 Safety Claim	1
1.2 Safety Instruction.....	1
1.3 Electromagnetic Interference Prevention	3
1.4 Laser Precaution	4
Chapter 2 Overview	6
2.1 Introduction	6
2.2 Key Features	6
2.3 Parameter Description	6
2.4 Naming Rule	8
Chapter 3 Appearance	9
Chapter 4 Interface and Indicator	11
4.1 12-Pin Interface	11
4.2 Indicator	12
Chapter 5 Installation	14
5.1 Installation Preparation	14
5.2 Install Device	15
Chapter 6 Device Connection	20
6.1 Install Client Software	20
6.2 Turn off Firewall	21
6.3 Set PC Network	21
6.4 Set Device Network	22
6.5 Connect Device to Client Software.....	23
Chapter 7 Quick Started with Client Software	24
7.1 Client Software Layout	24
7.2 Device Debugging.....	26
7.2.1 Set Original Image	27
7.2.2 Set Point Cloud Data	27
7.2.3 Set Depth Image	28

7.2.4 Set Trigger.....	29
7.2.5 Set System Calibration.....	29
7.2.6 Save Parameters.....	30
7.2.7 Output Data	30
Chapter 8 Camera Parameters	31
8.1 Trigger Settings.....	31
8.1.1 Set Frame Rate	31
8.1.2 Set Line Scan.....	32
8.1.3 Set Trigger Mode	33
8.1.4 Set Frame Trigger	33
8.1.5 Set Encoder Trigger.....	36
8.2 Acquisition Range Advanced Settings	39
8.2.1 Set Measurement Range	39
8.2.2 Set Binning.....	42
8.2.3 Set Capture Area.....	42
Chapter 9 Shot Feature Parameters	44
9.1 Light Intensity Settings.....	44
9.2 Sensitivity Settings	45
9.2.1 Set Detection Sensitivity	45
9.2.2 Set Single Frame HDR	47
9.2.3 Set Exposure Mode	48
9.2.4 Set Gain	49
9.2.5 Set Light Intensity Control.....	49
9.3 Interference Removal.....	50
9.3.1 Set Point Select Mode	50
9.3.2 Set Noise Filter	51
9.4 X Axis Invalid Data Process.....	53
Chapter 10 Amend Feature Parameters	54
10.1 Image Output Settings	54
10.2 Filter Settings.....	55
Chapter 11 I/O Electrical Feature and Wiring	57
11.1 I/O Electrical Feature	57

11.1.1 Differential Input Circuit	57
11.1.2 Differential Output Circuit.....	58
11.1.3 Opto-Isolated Input Circuit	58
11.2 Device Wiring	59
11.2.1 Differential Input Wiring	59
11.2.2 Opto-Isolated Input Wiring	61
Chapter 12 Device Calibration	63
12.1 Preparation	63
12.2 System Calibration	63
Chapter 13 Other Functions.....	65
13.1 Feature Save	65
13.2 Update Firmware	66
13.3 File Access Control.....	67
Chapter 14 FAQ (Frequently Asked Question).....	68
14.1 Why there is no device listed after I run the client software?	68
14.2 Why the image is very dark?.....	68
14.3 Why the image quality is very poor during the live view?	68
14.4 Why the image is black and without the laser line in origin image mode?.....	69
14.5 Why fail to save images or single frame point cloud?.....	69
14.6 Why exception occurs when previewing the point cloud?	69
14.7 Why depth images cannot be obtained during preview?	70
Chapter 15 Revision History	71

Chapter 1 Safety Instruction

The safety instructions are intended to ensure that the user can use the device correctly to avoid danger or property loss. Read and follow these safety instructions before installing, operating and maintaining the device.

1.1 Safety Claim

- To ensure personal and device safety, when installing, operating, and maintaining the device, follow the signs on the device and all safety instructions described in the manual.
- The note, caution and danger items in the manual do not represent all the safety instructions that should be observed, but only serve as a supplement to all the safety instructions.
- The device should be used in an environment that meets the design specifications, otherwise it may cause malfunctions, and malfunctions or component damage caused by non-compliance with relevant regulations are not within the scope of the device's quality assurance.
- Our company will not bear any legal responsibility for personal safety accidents and property losses caused by abnormal operation of the device.

1.2 Safety Instruction

Caution

- Do not install the device if it is found that the device and accessories are damaged, rusted, water ingress, model mismatch, missing parts, etc., when unpacking.
- Avoid storage and transportation in places such as water splashing and rain, direct sunlight, strong electric fields, strong magnetic fields, and strong vibrations.
- Avoid dropping, smashing or vigorously vibrating the device and its components.
- It is forbidden to install the indoor device in an environment where it may be exposed to water or other liquids. If the device is damp, it may cause fire and electric shock hazard.
- Place the device in a place out of direct sunlight and ventilation, away from heat sources such as heaters and radiators.
- The supplied bracket in the package is only applicable for this device, and using with other equipment may cause instability and injury.
- This is a Class A device. In the living environment, this device may cause radio interference. In this case, the user may be required to take practical measures against the interference.
- In the use of the device, you must be in strict compliance with the electrical safety regulations of the nation and region.
- Do not connect multiple devices to the same power adapter. Exceeding the adapter load

may cause a fire due to excessive heat generation.

- Use the power adapter provided by the official manufacturer. The power adapter must meet the Limited Power Source (LPS) requirements. For specific requirements, please refer to the device's technical specifications.
- Do not cover the device's plug or outlet for disconnecting power supply.
- It is strictly forbidden to wire, maintain, and disassemble the device that is powered on. Otherwise there is a danger of electric shock and a damage to device.
- Make sure that the device is installed in good condition, the wiring is firm, and the power supply meets the requirements before powering on the device.
- For a device with a power switch, please use the switch to power on and off. It is strictly forbidden to plug and unplug the power cord.
- If the device emits smoke, odor or noise, please turn off the power and unplug the power cord immediately, and contact the dealer or service center in time.
- It is strictly forbidden to touch any terminal of the device when operating it. Otherwise there is a danger of electric shock.
- It is strictly forbidden for non-professional technicians to detect signals during device operation, otherwise it may cause personal injury or device damage.
- Avoid aiming the image sensor at strong light in direct mode or reflection mode, such as laser beams, otherwise the image sensor will be damaged.
- Please keep the image acquisition window clean. It is recommended to wipe it with a clean cloth that is moistened with alcohol (75% or less). When the product is not in use, dust protection is required. Damage caused by improper maintenance will not be liable for warranty.
- If the device does not work properly, please contact your dealer or the nearest service center. Never attempt to disassemble the device yourself. We shall not assume any responsibility for problems caused by unauthorized repair or maintenance.
- In order to ensure the stability of the depth data, avoid enabling the depth data measurement function of the device immediately after the installation. It is recommended to start the measurement at least one hour after the electric current is taken on the device to ensure the uniform heat diffusion of the internal device.
- Please dispose of the device in strict accordance with the relevant national or regional regulations and standards to avoid environmental pollution and property damage.

Note

- Check whether the device's package is in good condition, whether there is damage, intrusion, moisture, deformation, etc. before unpacking.
- Check the surface of the device and accessories for damage, rust, bumps, etc. when unpacking.
- Check whether the quantity and information of the device and accessories are complete after unpacking.
- Store and transport the device according to the storage and transport conditions of the device, and the storage temperature and humidity should meet the requirements.
- It is strictly prohibited to transport the device in combination with items that may affect or damage the device.
- Quality requirements for installation and maintenance personnel:

- Qualification certificate or working experience in weak current system installation and maintenance, and relevant working experience and qualifications. Besides, the personnel must possess the following knowledge and operation skills.
- The basic knowledge and operation skills of low voltage wiring and low voltage electronic circuit connection.
- The ability to comprehend the contents of this manual.
- Please read the manual and safety instructions carefully before installing the device.
- Please install the device strictly according to the installation method in this manual.
- Do not contact the device with strong acids, alkalis, oils, greases or organic solutions such as thinners.
- To prevent injury, the device must be securely fastened to the profile.
- Do not expose the device directly to flashlights, high-frequency switch lighting devices, or to sunlight, which may affect the performance.

1.3 Electromagnetic Interference Prevention

- Make sure that the shielding layer of cables is intact and 360° connected to the metal connector when using shielded cables.
- Do not route the device together with other equipment (especially servo motors, high-power devices, etc.), and control the distance between cables to more than 10 cm. Make sure to shield the cables if unavoidable.
- The control cable of the device and the power cable of the industrial light source must be wired separately to avoid bundled wiring.
- The power cable, data cable, signal cable, etc. of the device must be wired separately. Make sure to ground them if the wiring groove is used to separate the wiring and the wiring groove is metal.
- During the wiring process, evaluate the wiring space reasonably, and do not pull the cables hard, so as not to damage the electrical performance of the cables.
- If the device is powered on and off frequently, it is necessary to strengthen the voltage isolation, and consider adding a DC/DC isolation power supply module between the device and the adapter.
- Use the power adapter to supply power to the device separately. If centralized power supply is necessary, make sure to use a DC filter to filter the power supply of the device separately before use.
- The unused cables of the device must be insulated.
- When installing the device, if you cannot ensure that the device itself and all equipment connected to the device are well grounded, you should isolate the device with an insulating bracket.
- To avoid the accumulation of static electricity, ensure that other equipment (such as machines, internal components, etc.) and metal brackets on site are properly grounded.
- During the installation and use of the device, high voltage leakage must be avoided.
- Use a figure-eight bundle method if the device cable is too long.
- When connecting the device and metal accessories, they must be connected firmly to maintain good conductivity.

- Use a shielded network cable to connect to the device. If you use a self-made network cable, make sure that the shielding shell at the aviation head is well connected to the aluminum foil or metal braid of the shielding cable.

1.4 Laser Precaution

The device complies with IEC60825.1:2014.

Caution

- Do not look directly at the laser beam, and if necessary, adjust the direction of direct eye gaze or close your eyes for protection.
- Do not use optical instruments (such as telescopes, magnifier) to observe the laser beam.
- Do not place optical instruments (such as mirrors) within the irradiation range of the laser beam.
- The laser radiation emitted from the device can cause eye injuries, burning of skin or inflammable substances.
- Wear the laser safety goggles within the operation range of the device. Do not look directly at the laser beam, even if wearing the laser safety goggles.
- The wavelength of the laser safety goggles must include the peak wavelength of the laser, and the optical density must be greater than OD5+.
- Avoid shining the laser on highly reflective materials. If it is unavoidable, the angle of the reflective material should be adjusted to prevent damage caused by laser reflection.
- Turn off the laser when the device is not in use.
- Please use the control or adjustment devices in accordance with the regulations of this manual to avoid potential hazardous radiation exposure.
- Please use this device correctly and safely in accordance with the contents of this manual and the local standards and laws and regulations. Otherwise the operator may be exposed to the risk of injury, electric shock, or radiation from the laser.

The laser-related parameters are shown below.

Table 1-1 Laser Parameters

Device Model	Laser Safety Class	Wavelength	Beam Divergence Angle	Pulse Width	Repetitive Frequency	Max. Power	Nominal Ocular Hazard Distance (NOHD)
MV-DP4020-01P	Class3B	405±5 nm	0.262	946 ns, range: 0 ns to 950 ns	1 MHz	40 mW	1000 mm
MV-DP4060-01P	Class2	405±5 nm	0.314	946 ns, range: 0 ns to 950 ns	1 MHz	1.66 mW	1000 mm

3D Laser Profile Sensor V2.0 User Manual

MV-DP4090-01P	Class3R	405±5 nm	0.611	946 ns, range: 0 ns to 950 ns	1 MHz	10 mW	1000 mm
MV-DP4180-01P	Class3R	405±5 nm	0.611	946 ns, range: 0 ns to 950 ns	1 MHz	10 mW	2500 mm
MV-DP4430-03P	Class3R	650±5 nm	0.698	946 ns, range: 0 ns to 950 ns	1 MHz	10 mW	2500 mm
MV-DP4940-03P	Class3R	650±5 nm	0.611	946 ns, range: 0 ns to 950 ns	1 MHz	10 mW	2500 mm
MV-DP2060-01P	Class3R	405±10 nm	0.611	946 ns, range: 0 ns to 950 ns	1 MHz	8 mW	1000 mm

The laser labels are shown below.

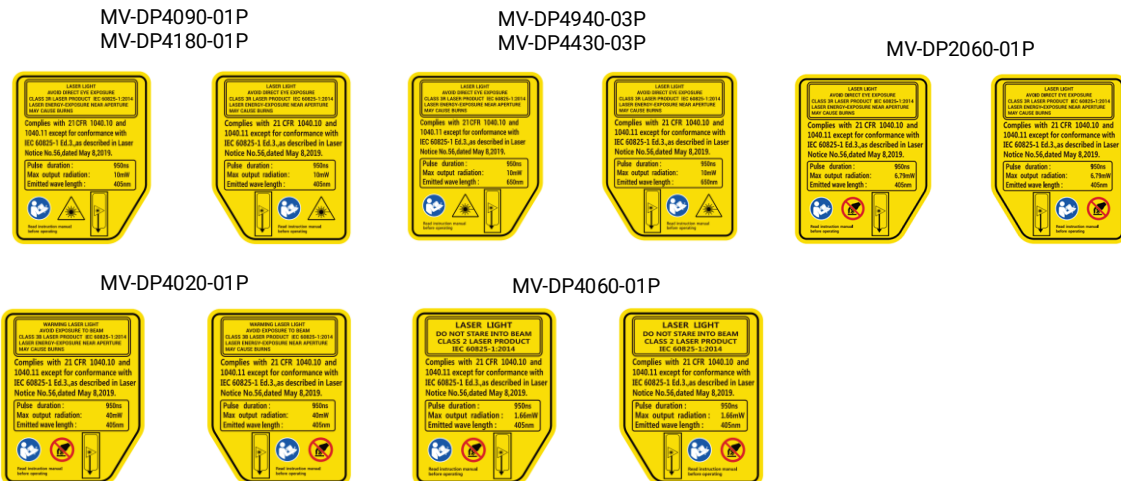

Figure 1-1 Laser Label

Chapter 2 Overview

2.1 Introduction

With built-in high-accuracy algorithm, image process algorithm of wide dynamic range and data integration algorithm, the 3D laser profile sensor can output high accurate 3D point cloud data in real-time by combining high frame rate chip and accurate laser control. With compact structure, high integration and easy operation, it is widely applied into consumer electronics, electronic manufacturing, automobile industry, etc.

2.2 Key Features

- Built-in high-accuracy algorithm and accuracy is up to submicron level.
- Supports multiple exposure modes with good robustness.
- Adopts multiple-frame integration technology to provide complete profiles.
- Provides multiple filter modes with stable data.
- Supports ROI selection and auto setting for easier operation.

Note

- The device functions may differ by models.
 - For specific device functions, refer to the device's user manual.
-

2.3 Parameter Description

The key performance parameters of the device are shown below.

Note

Refer to the device's specification for detailed parameter information. Parameters mentioned in the specification are tested in the laboratory environment with temperature of 25 °C (77 °F).

Table 2-1 Parameter Description

Parameters	Description
Scan Frequency	The image quantity collected by the device per unit time.
Measurement Range (MR)	The depth range that the device can measure. If the measured object is not in the measurement range, and effective data cannot be obtained.

3D Laser Profile Sensor V2.0 User Manual

Reference Distance	The distance between the bottom of the device and the center of the measurement range.
Near Field of View	The size of the field of view corresponds to the measurement range closest to the device.
Far Field of View	The size of the field of view corresponds to the measurement range farthest to the device.
Resolution (X-axis)	The distance of adjacent profile points in single profile data, and it is determined by the field of view and single profile point quantity.
Resolution (Z-axis)	It is the fixed height position within the measurement range, and the min. height difference that the device can detect. This parameter is determined by the device installation position and algorithm accuracy.
Repeatability (Z-axis)	In the measurement range, the same target area is repeatedly measured, and the max. deviation value of measurement result is repeated accuracy. This parameter reflects the measurement stability performance of the device.
Linearity Z-axis ($\pm\%$ of MR)	It indicates the deviation between the measured value and the true value of the measured object within the measurement range. This parameter reflects the absolute measurement capability of the device.

The measurement range diagram is shown below.

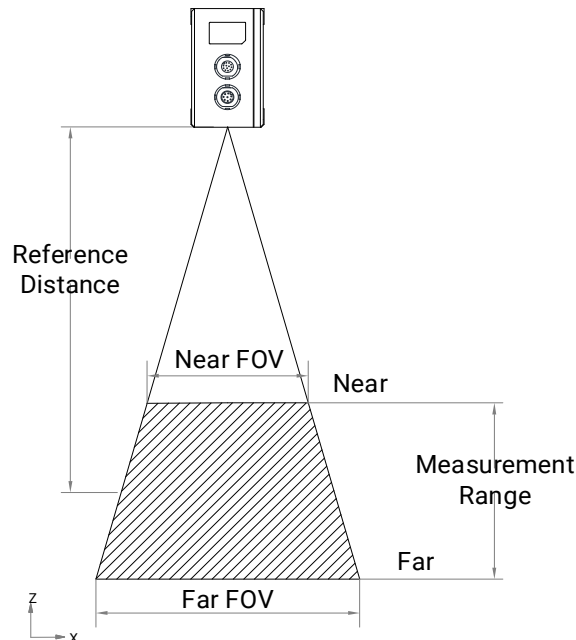

Figure 2-1 Measurement Range Diagram

2.4 Naming Rule

3D Laser Profile Sensor

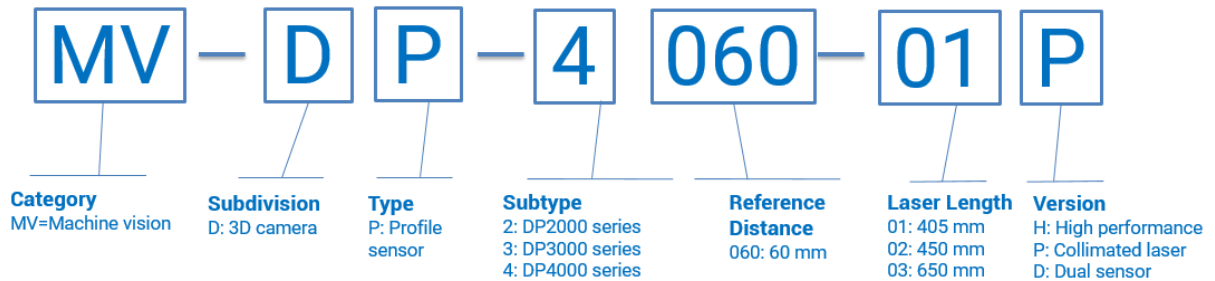

Figure 2-2 Naming Rule

Chapter 3 Appearance

Note

Appearance here is for reference only. Refer to the device's specification for detailed dimension information.

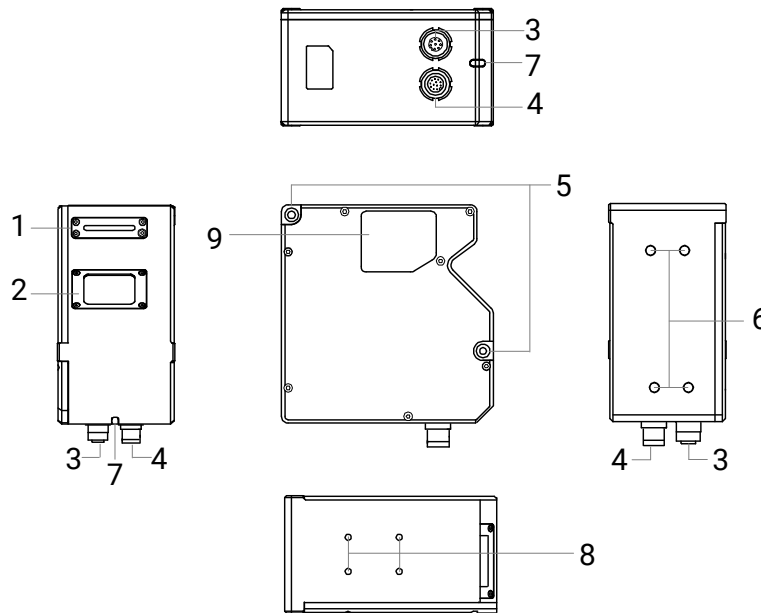

Figure 3-1 Device Appearance

Table 3-1 Component Description

No.	Name	Description
1	Laser	It sends out laser to object surface.
2	Image Sensor	It acquires the laser profile of the object.
3	Network Interface	It is a gigabit Ethernet interface to transmit data. The interface is designed with threads to tighten connection between the device and cable.
4	12-Pin Interface	It provides power, I/O and serial port function. The interface is designed with threads to tighten connection between the device and cable.
5	Mounting Hole	It refers to 2 mounting holes each on the side of the device, and these holes are used to fix the device. Refer to device's specification for screw information.
6	Screw Hole (Top)	It refers to the screw holes on the top of the device, and these screw holes are used to fix the device. Refer to device's

3D Laser Profile Sensor V2.0 User Manual

		specification for screw information.
7	Indicator	It displays the operating status of the device.
8	Screw Hole (Side)	It refers to 4 screw holes on the side of the device, and these screw holes are used to install the baffle. Refer to device's specification for screw information.
9	Laser Label	It shows laser information.

Note

- The mounting holes and screw holes (top) are both used to fix the device. You can select one of them to fix the device according to actual demands.
 - For some devices, the positions of the network interface and the 12-pin interface may differ from the image of device appearance shown above. You can identify the interfaces via the labels on the device (PWR indicates the power and I/O interface, and LAN indicates the network interface).
-

Chapter 4 Interface and Indicator

4.1 12-Pin Interface

The device has a 12-pin M12 interface that provides power, input and output signals, and the serial port signal.

Note

The pin definition may differ by the device model.

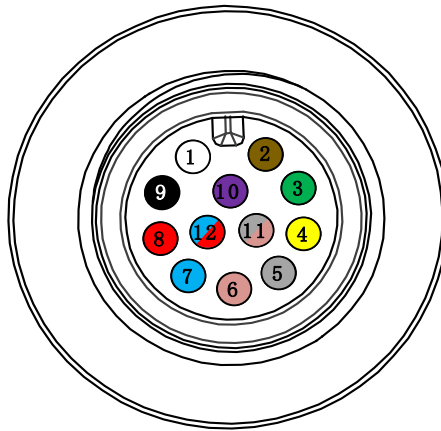

Figure 4-1 12-Pin Interface

Table 4-1 Pin Definition of DP4000 Series Device

No.	Cable Color	Signal	I/O Signal Source	Description
1	White	POWER_IN	--	DC power supply positive
2	Brown	GND	--	Power supply ground
3	Green	IO_OUT1_P	Line 1+	Differential output I/O 1 positive
4	Yellow	IO_OUT1_N	Line 1-	Differential output I/O 1 negative
5	Gray	IO_IN0_N	Line 0-	Differential input I/O 0 negative
6	Pink	IO_IN0_P	Line 0+	Differential input I/O 0 positive
7	Blue	IO_IN3_N	Line 3-	Differential input I/O 3 negative
8	Red	IO_IN3_P	Line 3+	Differential input I/O 3 positive
9	Black	IO_IN6_N	Line 6-	Differential input I/O 6 negative
10	Purple	IO_IN6_P	Line 6+	Differential input I/O 6 positive

No.	Cable Color	Signal	I/O Signal Source	Description
11	Gray/Pink	232_RXD	--	RS-232 input
12	Red/Blue	232_TXD	--	RS-232 output

Table 4-2 Pin Definition of DP2000/DP3000 V2.0 Series Device

No.	Cable Color	Signal	I/O Signal Source	Description
1	White	POWER_IN	--	DC power supply positive
2	Brown	GND	--	Power supply ground
3	Green	IO_OUT1_P	Line 1+	Differential output I/O 1 positive
4	Yellow	IO_OUT1_N	Line 1-	Differential output I/O 1 negative
5	Gray	IO_IN0_COM	Line 0-	Opto-isolated input I/O 0 negative
6	Pink	IO_IN0	Line 0+	Opto-isolated input I/O 0 positive
7	Blue	IO_IN3_N	Line 3-	Differential input I/O 3 negative
8	Red	IO_IN3_P	Line 3+	Differential input I/O 3 positive
9	Black	IO_IN6_N	Line 6-	Differential input I/O 6 negative
10	Purple	IO_IN6_P	Line 6+	Differential input I/O 6 positive
11	Gray/Pink	IO_IN9_COM	Line 9-	Opto-isolated input I/O 9 negative
12	Red/Blue	IO_IN9	Line 9+	Opto-isolated input I/O 9 positive

 **Note**

You should refer to the table above and the label attached to the power and I/O cable to wire the device.

4.2 Indicator

The device's indicator is used to indicate the operating status of the device.

 **Note**

When the indicator is lit up, flashing rapidly, flashing slowly, or flashing very slowly, its unlit interval is 5 sec, 0.2 sec, 1 sec, or 2 sec respectively.

Table 4-3 Indicator Description

Indicator Color	Indicator Status	Device Status
Blue	Solid	<ul style="list-style-type: none"> The device is operating normally.

3D Laser Profile Sensor V2.0 User Manual





Indicator Color	Indicator Status	Device Status
		<ul style="list-style-type: none">• The device's firmware is updated.
Green	Flashing rapidly	The device acquires images normally, but the laser line is not within the field of view.
	Solid	The device acquires images normally, and the laser line is within the field of view.
Red	Flashing very slowly	The device's IP address conflicts or the network is disconnected.
	Solid	<ul style="list-style-type: none">• Loading uboot failed.• Updating firmware failed.• A fatal exception occurs.• Other exceptions occur.
Red and blue	Flashing alternatively	The device is updating its firmware.

Chapter 5 Installation

5.1 Installation Preparation

You need to prepare following accessories before device installation.

Table 5-1 Accessories

No.	Name	Image	Quantity	Description
1	Power and I/O cable		1	It refers to the 12-pin power and I/O cable with M12 interface. You need to purchase separately.
2	Network Cable		1	It refers to the gigabit Ethernet network cable, and its interface is M12 to RJ45 connector. You need to purchase separately.
3	Switch Power Supply		1	It refers to the switch power supply above 24 V, 1 A. You need to purchase separately.
4	Screws		Several	It refers to the supplied M4x35, M3x8, or M4x55 screws, which may differ by device model.

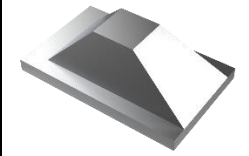
No.	Name	Image	Quantity	Description
5	System Calibration Block		1	It is used to convert the sensor's coordinate data into system coordinate data. You need to purchase separately.

Note

- Before any installation or maintenance work, please disconnect the power supply from the utility, and ensure that it will not be reconnected inadvertently.
- Do not install the power supply in places with high moisture or near the water.
- Do not install the power supply in places with high ambient temperature or near fire source.
- Please install the exposed high-voltage terminals on the power supply in a closed chassis or cabinet to prevent accidental contact.
- Keep enough insulation distance between mounting screws and internal components of power supply.
- Fans and ventilation holes must be kept free from any obstructions. Also a 10 cm to 15 cm clearance should be kept when the adjacent device is a heat source.
- The power supply must be grounded as required.
- Output current and output power must not exceed the rated values on specifications.
- Non-standard mounting or operating under high ambient temperature may increase the internal component temperature and will decrease the output power.
- All failure should be examined by a qualified technician. Do not remove the case of the power supply by yourself.
- Do not touch the power terminal for 5 minutes after the power is turned off, that may cause electric shock.

5.2 Install Device

Before You Start

- Make sure the device in the package is in good condition and all assembly parts are included.
- Make sure all the related equipment is power-off during the installation.

Note

- When installing the device, make sure that the device's X/Y direction is parallel with the datum plane, and the device's Y direction is same with its movement direction.
- The installation height depends on the field of view of the device and object size. Refer to the device's specification for specific reference distance and measurement range.

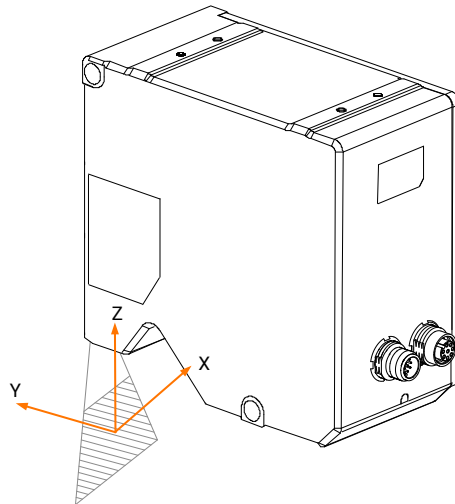

Figure 5-1 Installation Direction Diagram

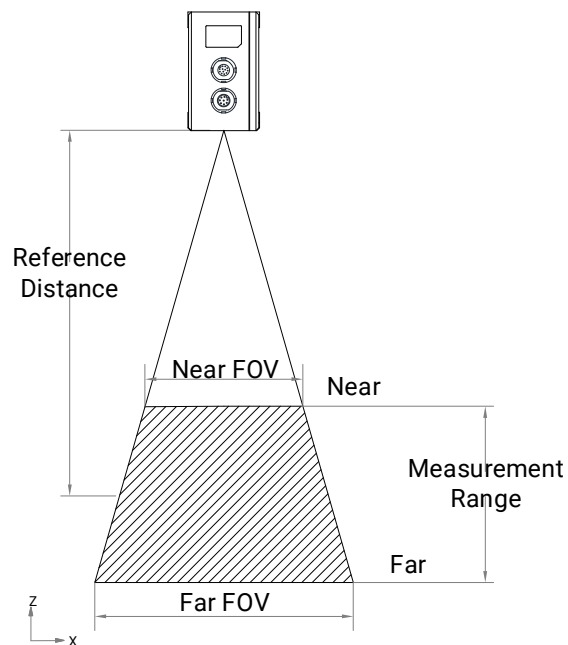

Figure 5-2 Distance Requirement

Steps

1. Use the M4 screws to fix the device to the mounting plate from the front side, or use the M3/M4/M5 screws to fix it from the top side.

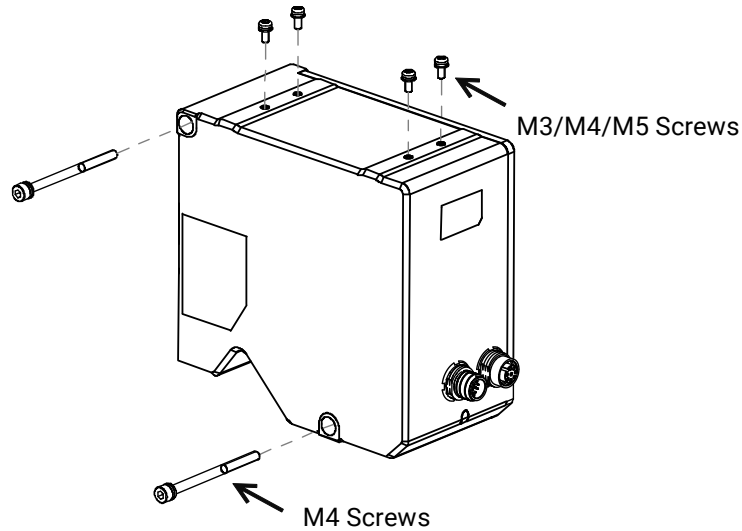

Figure 5-3 Fix Device

2. Use the network cable to connect the device to a switch or NIC.
3. Use the power and I/O cable to connect the device to a suitable switch power supply.

The device is easily affected by the environment, measured objects, angle, etc. When installing the device, pay attention to following items.

- Do not use the device in the environment with direct sun light. Otherwise, the measurement accuracy may be inaccurate.
- Do not keep the device too close to wall or baffle plate. Otherwise, the secondary reflection may occur that will affect the measurement accuracy.

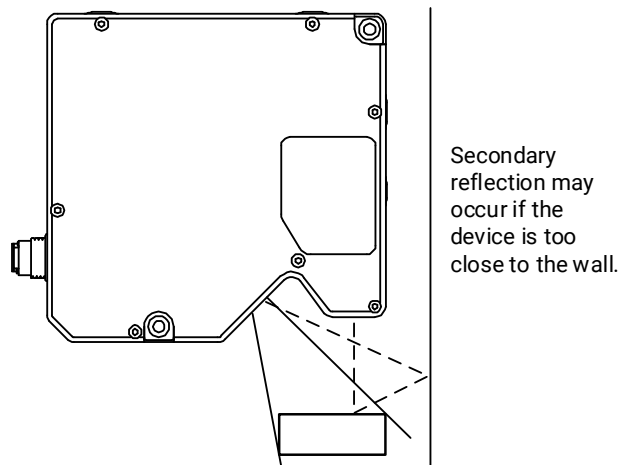

Figure 5-4 Secondary Reflection

- If measured objects have the features of absorbance, reflection or transmittance, the device's image data may lose, images may have noise, and central line cannot be extracted.

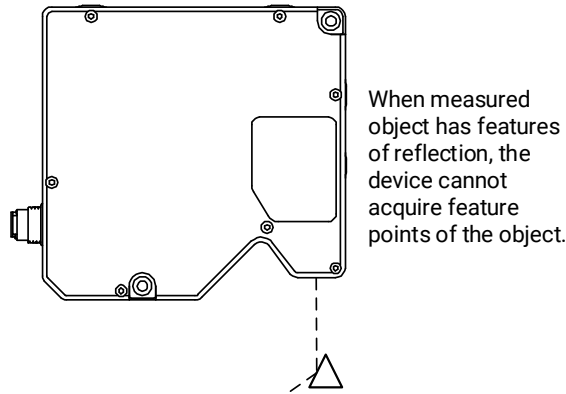

Figure 5-5 Reflection

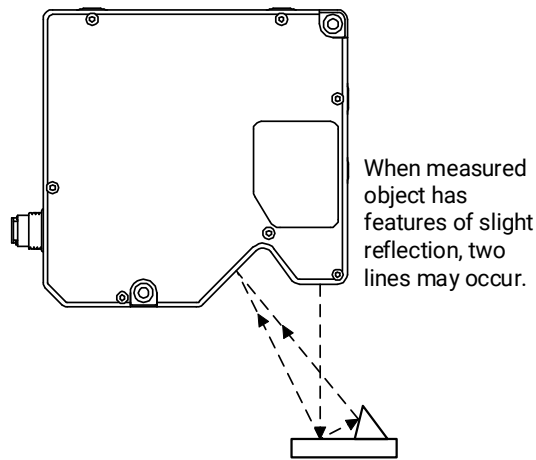

Figure 5-6 Slight Reflection

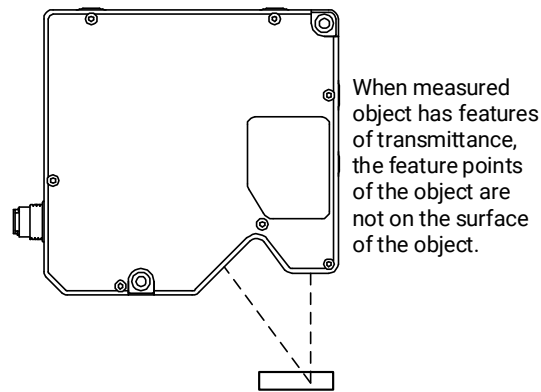

Figure 5-7 Transmittance

Due to imaging angle, certain measured objects may have a blind zone in the device field of view, as shown below.

- When there is the blind zone in X direction, you need to put the measured object near the center of field of view to reduce the size of the blind zone.
- When there is the blind zone in Y direction, it is recommended to install the device in an inclined position, or adjust the position of the measured object.

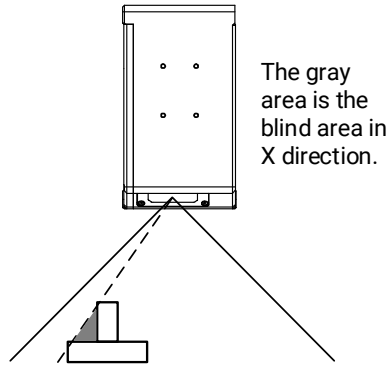

Figure 5-8 Blind Area in X Direction

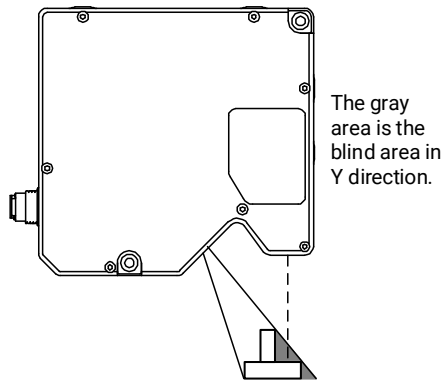

Figure 5-9 Blind Area in Y Direction

Chapter 6 Device Connection

Device connection to the client software is required for device's configuration and remote operations. This section introduces how to install the client software, set PC and device network, connect the device to the client software, etc.

6.1 Install Client Software

3DMVS is a client software for device configuration and remote operations.

Steps

Note

- Check the Windows version. The client software is compatible with 32/64-bit Windows 7/10 and 64-bit Windows 11.
 - You can get the client software installation package (V3.1.0 and above) from <https://en.hikrobotics.com/>.
 - The graphic user interface may differ by different versions of client software you use.
-

1. Double click the installation package to start installing the client software.
2. Select the language.
3. Read and check **Terms of the License Agreement**.
4. Click **Start Setup**.
5. Select installation directory and click **Next**.

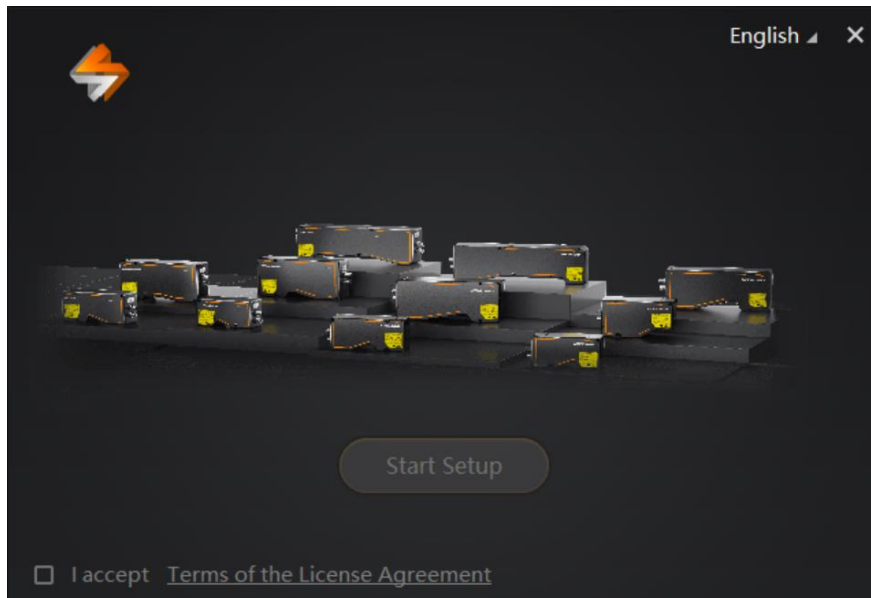

Figure 6-1 Installation Interface

6. Finish the installation according to the interface prompts.

6.2 Turn off Firewall

To ensure stable client running and image transmission, you are recommended turning off Windows firewall before using the client software.

Steps

Note

For different Windows versions, the path name or interface may differ. Please refer to the actual condition.

1. Go to Windows Firewall.

Windows 7 system: Click **Start** → **Control Panel** → **Windows Firewall**.

Windows 10 system: Click **Start** → **Control Panel** → **System and Security** → **Windows Defender Firewall** → **Firewall & network protection**.

Windows 11 system: Click **Start** → **Settings** → **Privacy & security** → **Windows Security** → **Firewall & network protection**.

2. For Windows 7 and 10 system, click **Turn Windows Defender Firewall on or off** on the left. For Windows 11, select the network and turn off in **Microsoft Defender Firewall**.

3. Select **Turn off Windows Defender Firewall (not recommended)**.

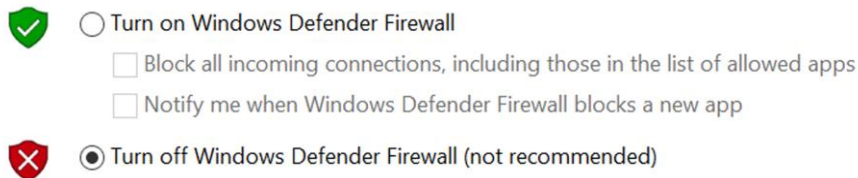

Figure 6-2 Windows Defender Firewall

4. Click **OK**.

6.3 Set PC Network

To ensure stable image transmission and normal communication between the PC and the device via client software, you need to set the PC network before using the client software.

Steps

Note

For different Windows versions, the path name or interface may differ. Please refer to the actual condition.

1. Go to PC network settings page: **Start** → **Control Panel** → **Network and Internet** → **Network and Sharing Center** → **Change adapter settings**.
2. Select NIC and set the IP obtainment mode.
 - Select **Obtain an IP address automatically** to get an IP address of the PC automatically.
 - Select **Use the following IP address** to set an IP address for the PC manually.

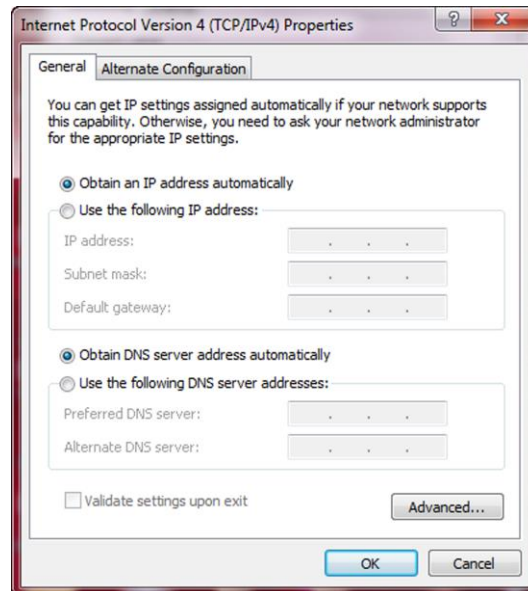

Figure 6-3 Set PC Network

3. Set NIC property.
 - 1) Go to NIC settings page: **Control Panel** → **Hardware and Sound** → **Device Manager** → **Network Adapter**.
 - 2) Select corresponding network interface card, and click **Advanced**.
 - 3) Set **Receive Buffers** and **Jumbo Packet** to its max. value.

6.4 Set Device Network

You can set and operate the device in the client software only when the device is in the same network segment with the PC where the client software is installed.

Steps

1. Double click the client software to run it, and the **Device List** window will pop up.
2. Click **Edit** to open the **Edit IP Address** window.

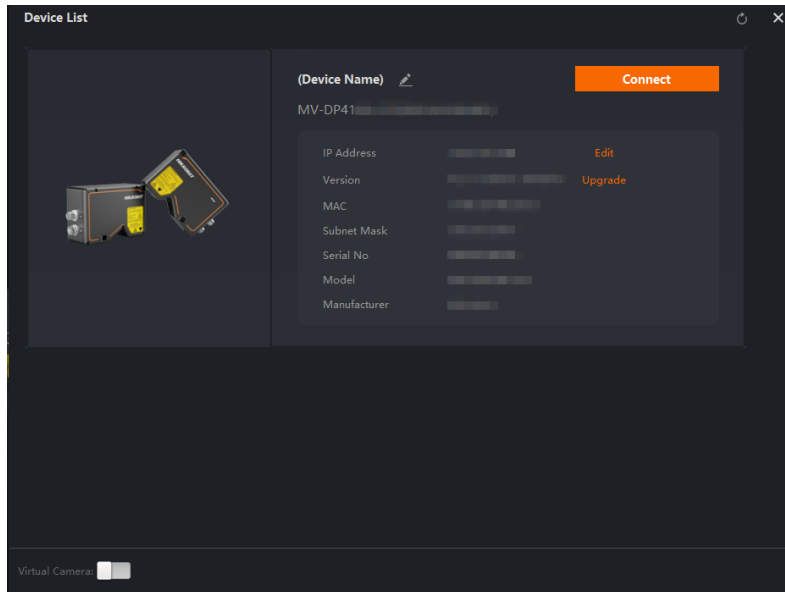

Figure 6-4 Device List

3. Set the IP address of the device in the same network segment with the PC.



Figure 6-5 Edit IP Address

Note

It is recommended to set the IP address as the static IP for device's stable operating.

6.5 Connect Device to Client Software

Make sure your device IP address is in the same network segment with the PC where you installed the client software before connecting the device to it.

Open the **Device List** window, and click **Connect** to connect the device to the client.

Chapter 7 Quick Started with Client Software

This section introduces the layout of the client software, and basic operations about device in the client software.

7.1 Client Software Layout

After connecting to the device, the client software can read the device attributes and display them.

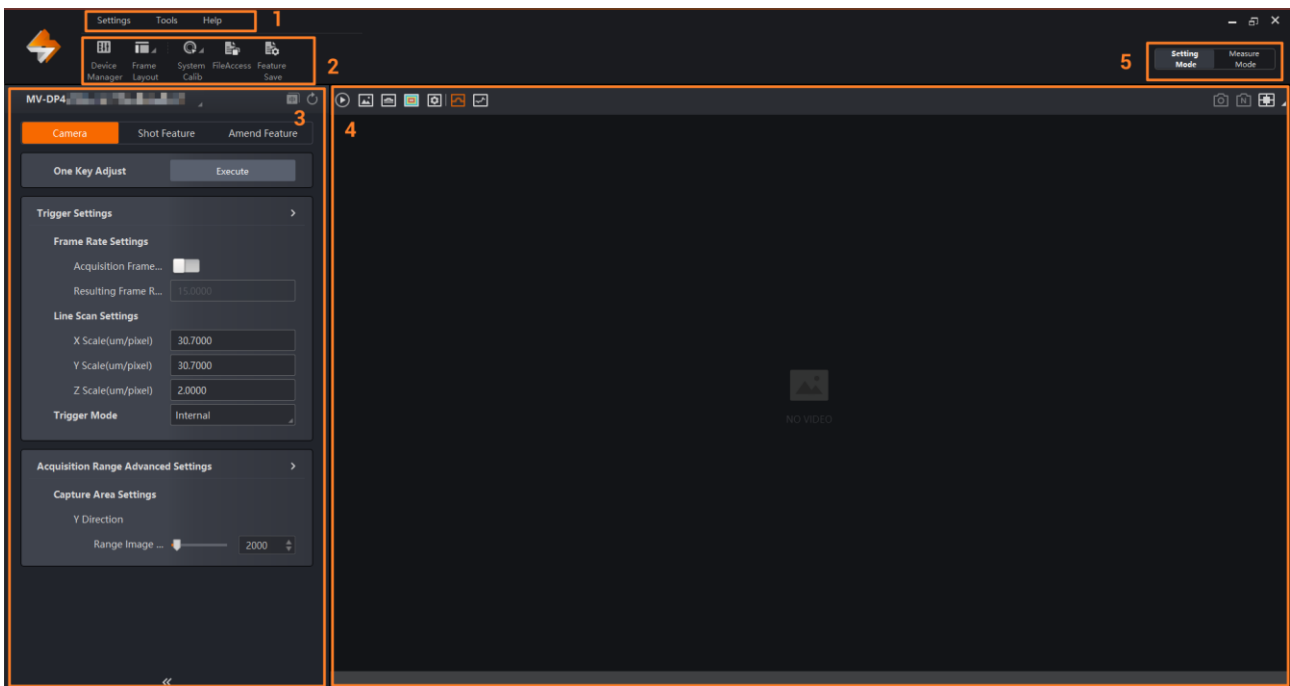

Figure 7-1 Main Window

Note

For specific main window of the client, please refer to the actual one you got.

Table 7-1 Description of the Main Window

No.	Name	Description
1	Menu Bar	The menu bar displays function modules, including Settings , Tools , and Help .
2	Control Toolbar	The control toolbar provides quick operations for the device.
3	Settings Area	You can view and set device's parameters.
4	Live View Area	This area displays device's images, and you can switch image

No.	Name	Description
		mode, capture images, etc.
5	Mode Switching	You can switch to Setting Mode or Measure Mode .

 **Note**

For specific attributes, please refer to the actual device you got.

Table 7-2 Device Attribute Description

Attribute (Level I)	Attribute (Level II)	Attribute (Level III)	Description
Camera	One Key Settings		After you configure some parameters, it can automatically generate a set of parameters compatible to the device.
	Trigger Settings	Frame Rate Settings	You can control the frame rate manually.
		Line Scan Settings	You can set sampling precision.
		Trigger Mode	You can select different trigger modes for image acquisition.
		Frame Trigger Control	You can set sampling interval and frame trigger source and trigger-related parameters.
		Encoder Trigger Control	You can set parameters related to frequency converter control and encoder control.
	Acquisition Range Advanced Settings	Measurement Range Settings	You can draw ROI, shield region, and effective region, and set measurement range.
		Binning Settings	You can set Binning to reduce resolution and improve image brightness.
		Capture Area Settings	You can set profile quantity in one depth image to configure capture area in Y direction.
	Shot Feature	Light Intensity Settings	

Attribute (Level I)	Attribute (Level II)	Attribute (Level III)	Description
	Sensitivity Settings	Detection Sensitivity	You can adjust parameters related to light intensity for accurate extraction result of laser center line in the original image.
		Single Frame HDR	After you enable this function, multi-exposure fusion and overexposure control will be executed within a frame to improve dynamic range.
		Exposure Control	When detection sensitivity is set as custom, you can adjust exposure manually.
		Gain	You can set gain to adjust the brightness of the image.
		Light Intensity Control	You can set laser ratio to adjust light intensity.
	Interference Removal		You can set point select mode for removing noise point.
	X Axis Invalid Data Process		After you enable this function, the invalid data will be filled.
Amend Feature	Image Output Settings		You can set parameters related to outputted depth image.
	Filter Settings		You can set filtering window and execute filtering of profile points in the window.

7.2 Device Debugging

After installing the client software, you need to debug the device, and the overall process is shown below.



Figure 7-2 Overall Flow

You can switch image mode on the toolbar.

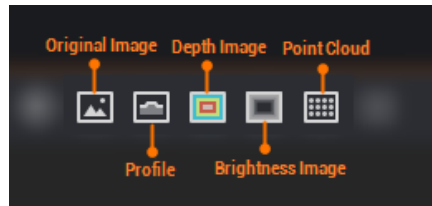



Figure 7-3 Image Mode

7.2.1 Set Original Image

Click  to switch to the original mode, draw ROI (Region of Interest), and set image parameters in the origin image mode.

- Drawing ROI is to block the invalid region, reduce outputted bandwidth, and increase outputted frame rate. Refer to section [Set ROI](#) in *3D Laser Profile Sensor User Manual* for details.
- Setting image parameters is to select high precision or wide dynamic in detection sensitivity, or select custom to adjust the device's exposure and gain to make sure the brightness of the device is enough and the central line can be extracted. Refer to section [Set Exposure Mode](#) and section [Set Detection Sensitivity](#) in *3D Laser Profile Sensor User Manual* for details.

Note

Methods for adjusting exposure and gain vary in different situations.

- If the image is too dark, you can increase the exposure and gain appropriately. If the exposure is too large to influence the device frame rate, the gain should be increased.
- If the image is too bright, you can reduce the exposure and gain appropriately.
- If the image is partially too bright and too dark, you can enable the multiple exposure function.

7.2.2 Set Point Cloud Data

In order to get an ideal image effect, you need to process profile data and stitch them into point cloud data. The flow is shown below.



Figure 7-4 Process Flow

Steps

1. Click  to switch to the profile mode.
2. Go to **Shot Feature** → **Sensitivity Settings** → **Detection Sensitivity** to set related parameters for extracting the central line. Refer to section [Set Detection Sensitivity](#) in *3D Laser Profile Sensor User Manual* for details.

3. Go to **Shot Feature** → **X Axis Invalid Data Process** and go to **Amend Feature** → **Filter Settings** to preprocess point cloud data. Refer to section [X Axis Invalid Data Process](#) and section [Filter Settings](#) in *3D Laser Profile Sensor User Manual* for details.
4. Go to **Camera** → **Trigger Settings** → **Line Scan Settings** to set step distance and go to **Camera** → **Acquisition Range Advanced Settings** → **Capture Area Settings** to set range image height for point cloud data stitching.
 - Step distance can be calculated by relative displacement speed of measured object and the device's real-time frame rate.
 - Range image height refers to the quantity of profiles to be stitched.

7.2.3 Set Depth Image

Before You Start

Make sure the device has stopped acquiring images.

Note

- After you click **Execute** in **One Key Adjust** and set the related parameters, a set of parameters of the device will be generated automatically.
- Save the parameters before clicking the quick settings button, otherwise all parameters except original image ROI will be reset.

Steps

1. Go to **Camera**, and click **Execute** in **One Key Adjust**.

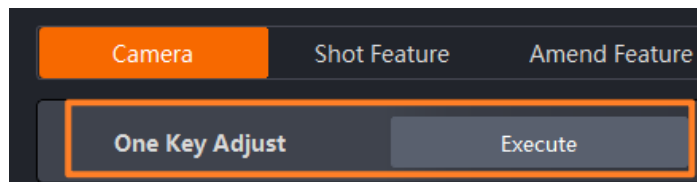

Figure 7-5 Quick Parameter Setting for Depth Image

2. Set the **Trigger Mode**. The options are introduced below.
 - **Free Collection Mode** cannot control the device to start or stop acquiring images, but can control the acquisition frame rate via internal signal.
 - **Frame Trigger (Pulse Signal)** can control the device to start or stop acquiring images via external trigger or software trigger, and control the acquisition frame rate via internal signal.
 - **Line Trigger** cannot control the device to start or stop acquiring image, but can control the acquisition frame rate via encoder trigger.
 - **Frame (Pulse Signal) & Line Trigger** can control the device to start or stop acquiring images via external trigger or software trigger, and control the acquisition frame rate via encoder trigger.
3. Set the **Moving Speed** or **Encoder Resolution** according to the trigger mode you select.
 - If you set **Free Collection Mode** or **Frame Trigger (Pulse Signal)** as the trigger mode, the

Moving Speed should be set. It refers to the relative moving speed of the device and the object.

- If you set **Line Trigger** or **Frame (Pulse Signal) & Line Trigger** as the trigger mode, the **Encoder Resolution** should be set. It refers to the physical distance represented by one pulse period from the encoding device

4. Set **X/Y Direction Single Pixel Precision** and **Object Moving Distance**.

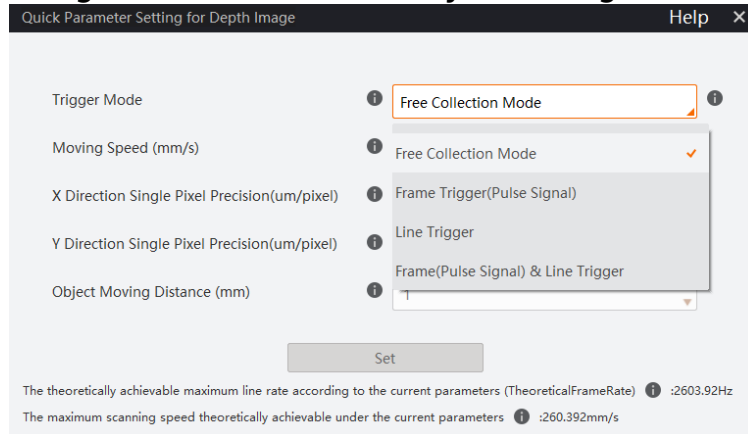

Figure 7-6 Set Related Parameters

5. Click **Set**. The success message will pop up.

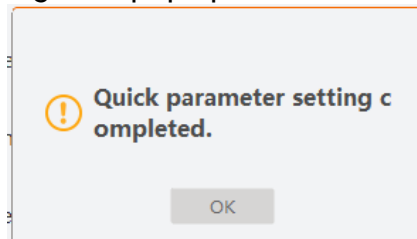



Figure 7-7 Quick Parameter Settings Succeeded

6. Click  on the control toolbar of the client software to start acquisition.

Note

If the **Frame Trigger (Pulse Signal)** or **Frame (Pulse Signal) & Line Trigger** is set as the trigger mode, you should select the trigger source in the pop-up window after you click **Set**.

7.2.4 Set Trigger

After wiring the device according to section [Wire Device](#) in *3D Laser Profile Sensor User Manual*, you need to set trigger-related parameters, and refer to section [Set Trigger Mode](#) in *3D Laser Profile Sensor User Manual* for details.

7.2.5 Set System Calibration

System calibration is required before using the device.

The system calibration can correct the installation deviation and datum plane of the

device, and get the three-dimensional data in the system coordinate system.

The device supports customized coordinate system zero position and coordinate direction to correct the relative deflection caused by device installation and motion mechanism movement.

System calibration is divided into line calibration, static calibration, dynamic calibration, and rotation calibration. For multi-camera scene, dynamic stitching calibration and static stitching calibration are also available. Different calibration methods are suitable for different scenarios. Refer to section [Device Calibration](#) in *3D Laser Profile Sensor User Manual* for details.

7.2.6 Save Parameters

After setting parameters and debugging images, you need to save them in case of restoring to default settings after restarting the device. Refer to section [Feature Save](#) in *3D Laser Profile Sensor User Manual* for details.

7.2.7 Output Data

The image data of the device can be stored via the client software, or obtained and outputted via the SDK.

- The 3DMVS client software can store the device's original images, point cloud data, and depth images. Refer to the ***3DMVS Client Software User Manual*** for details.
- The device can obtain, transform and store the device's original images, point cloud data and depth images via the SDK. Refer to the ***3D Laser Profile Sensor SDK Developer Guide*** for details.

Chapter 8 Camera Parameters

Note

The related parameters may differ by device model and firmware version.

8.1 Trigger Settings

8.1.1 Set Frame Rate

Frame rate refers to the image quantity that is acquired by the device per second. The higher frame rate, and shorter time used for image acquisition will be. The following 4 factors determine the device's frame rate in real-time.

- ROI: The larger resolution of the ROI, and the lower frame rate of the device.
- Image mode: The frame rate of the device differ by the image mode you selected. In general, the frame rate in the origin image mode is lower than that in the 3D point cloud.
- Exposure time: If the reciprocal of max. frame rate that the device supports is t , and when the configured exposure time is larger than t , the less the exposure time, the higher the frame rate will be. When the configured exposure time is less than or equal to t , and exposure time will not influence the frame rate.
- Binning: By using binning function, the device's resolution is reduced and the frame rate increases.

Note

- The Binning function is available for some models. Refer to the actual device you got.
 - Network bandwidth also affects the device frame rate. It is recommended to use the device in a Gigabit network environment.
-

Go to **Camera** → **Trigger Settings** → **Frame Rate Settings**, enable **Acquisition Frame Rate Control Enable**, and enter **Acquisition Frame Rate** according to actual demands. You can refer to **Resulting Frame Rate** to view the device's resulting frame rate.

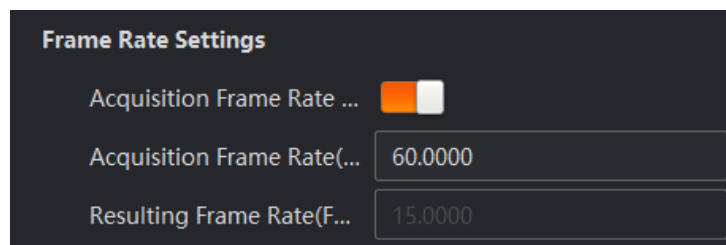

Figure 8-1 Set Frame Rate

Note

- If the real-time frame rate is smaller than configured frame rate, the device acquires images according to the real-time frame rate.
- If the real-time frame rate is larger than configured frame rate, the device acquires images according to the configured frame rate.

8.1.2 Set Line Scan

You can set parameters of sampling precision. Go to **Camera** → **Trigger Settings** → **Line Scan Settings** to set related parameters.

Table 8-1 Profile Algorithm Parameters

Parameters	Description
Step Distance (μm)	<p>The definition of the step distance may differ by the coordinate type. Refer to section Image Output Settings for details of coordinate type.</p> <p>For sensor and system coordinates, it refers to the distance of adjacent frames, and the unit is μm.</p> <p>For rotation coordinates, it refers to the angular spacing of adjacent frames, and the unit is 0.01°.</p>
X Scale (μm/pixel)	<p>It refers to the sampling interval in the depth image's X direction, and the unit is μm/pixel.</p> <p>When X Scale and Y Scale are the same, the image proportion is normal, without stretching or compression.</p>
Y Scale (μm/pixel)	<p>It refers to the sampling interval in the depth image's Y direction, and the unit is μm/pixel.</p> <p>The Y Scale can be the same as Step Distance.</p>
Z Scale (μm/pixel)	<p>It refers to the sampling interval in the depth image's Z direction, and the unit is μm/pixel.</p> <p>The value depends on int16 and measurement range.</p>



Figure 8-2 Set Sampling Precision

8.1.3 Set Trigger Mode

The device supports 4 types of trigger mode, including internal trigger, frame trigger, encoder trigger, and multiple trigger. Go to **Camera** → **Trigger Settings** → **Trigger Mode** to select different trigger modes.

Table 8-2 Trigger Mode Description

Trigger Mode	Description	Settings Method
Internal Trigger	The device acquires a frame of original image via internal signals, extracts a piece of valid profile data, and finally stitches multiple profile data to output a depth image.	The device will automatically execute internal trigger and continuous image acquisition without settings.
Frame Trigger	After receiving an external signal, the device starts to acquire images. It acquires a frame of the original image via internal signals, extracts a piece of valid profile data, and finally stitches multiple profile data to output a depth image.	Frame trigger source and other parameters should be set. Refer to section Set Frame Trigger for details.
Encoder Trigger	The device acquires a frame of original image via external signals, extracts a piece of valid profile data, and finally stitches multiple profile data to output a depth image.	Parameters of frequency converter control and encoder control should be set. Refer to section Set Encoder Trigger for details.
Multiple Trigger	After receiving an external signal, the device starts to acquire images. It acquires a frame of the original image via external signals, extracts a piece of valid profile data, and finally stitches multiple profile data to output a depth image.	Parameters of frame trigger and encoder trigger should be set.

8.1.4 Set Frame Trigger

Frame Trigger Source

The device supports 2 types of trigger source: **Software** and **Outside Interface**.

- **Software:** You can click **Execute** in **Trigger Software** to send the trigger signal to the device. An image will be acquired with each clicking on the device.
- **Outside Interface:** The device receives external signal via Line 0 for image acquisition.

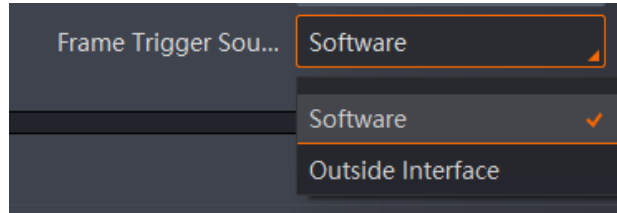

Figure 8-3 Frame Trigger Source

Note

Refer to section [I/O Electrical Feature and Wiring](#) for the details of I/O electrical feature and wiring method.

Frame Trigger Parameters

The supported trigger parameters may differ by the frame trigger source.

Table 8-3 Frame Trigger Sources and Related Parameters

Trigger Source Parameter	Software	Outside Interface
Acquisition Burst Frame Count	√	√
Frame Trigger Activation	×	√
Frame Trigger Delay	√	√
Trigger Duration	√	√
Frame Debouncer Time	×	√

● **Acquisition Burst Frame Count**

When **Acquisition Burst Frame Count** is 1, it is in single frame trigger mode. When **Acquisition Burst Frame Count** is larger than 1, it is in multi-frame trigger mode. If **Acquisition Burst Frame Count** is n and when inputting one trigger signal, the device stops acquiring after outputting n frame images. The sequence diagram of burst frame count is shown below.

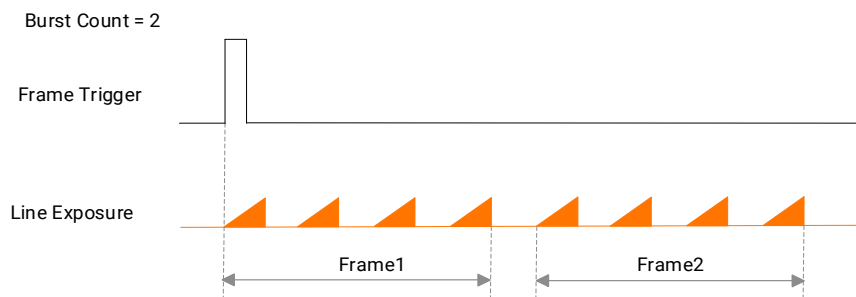

Figure 8-4 Sequence Diagram of Burst Frame Count

Note

The sequence diagram above use the rising edge as trigger activation and the device's profile quantity is 4.

• Frame Trigger Activation

The device supports trigger in the rising edge, falling edge, level high, or level low of the external signal. The principle and parameter of trigger activation are shown below.

Table 8-4 Trigger Activation Principle

Trigger Activation	Description
Rising Edge	When the level signal given by external device is on rising edge, the device receives the signal and triggers.
Falling Edge	When the level signal given by external device is on falling edge, the device receives the signal and triggers.
Level High	When the level signal given by external device is on level high, the device is acquiring images.
Level Low	When the level signal given by external device is on level low, the device is acquiring images.

Note

When rising edge and falling edge are selected, you can also set the trigger delay. When level high and level low are selected, the trigger delay is unavailable.

• Frame Trigger Delay

You can set trigger delay from device receiving trigger signal to device responding. Its sequence diagram is shown below.

Note

The sequence diagram below uses the rising edge as trigger activation.

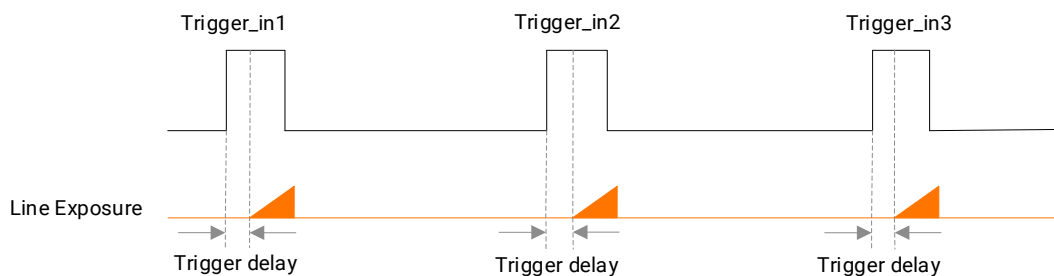

Figure 8-5 Sequence Diagram of Trigger Delay

• Trigger Duration

You can set the duration of the trigger signal in **Trigger Duration** (unit: μs).

When rising edge and falling edge are selected, the device will continue to generate images in the set time period after a trigger signal (rising edge or falling edge) is received.

When level high and level low are selected, the device will continue to generate images in the set time period after the level duration has expired.

● **Frame Debouncer Time**

When the device receives external trigger signals, signal bounce may occur and cause false trigger. Thus, it is necessary to debounce trigger signals.

If the configured debouncer time is larger than the time of trigger signal, the trigger signal will be ignored. The sequence diagram of trigger debouncer is shown below.

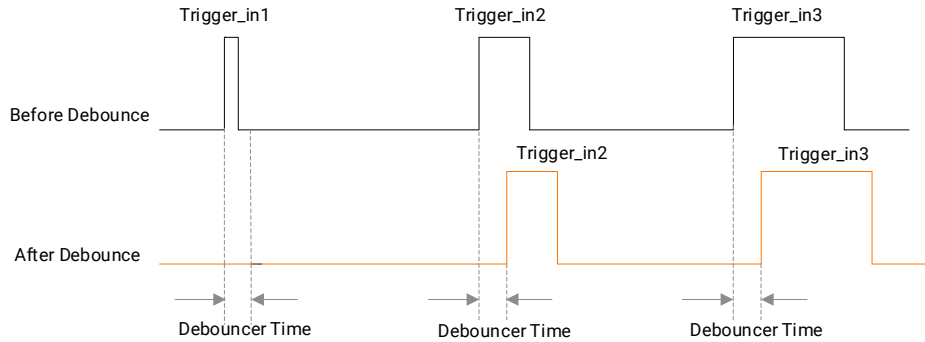

Figure 8-6 Sequence Diagram of Trigger Debouncer

Note

The sequence diagram above uses the rising edge as trigger activation.

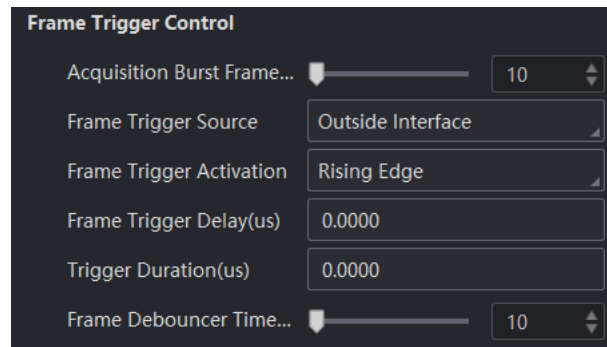

Figure 8-7 Frame Trigger Parameters

8.1.5 Set Encoder Trigger

Frequency Converter Control

Note

You need to consider the device's scan frequency when setting related parameters of the frequency converter in case the final trigger signal exceeds the device's max. scan frequency.

The shaft encoding control signal frequency can be converted into the line trigger signal

frequency required by the device via the frequency converter module, thus triggering the device.

The frequency converter module includes a pre-divider, a multiplier and a post-divider, which all act on the input signal in turn.

- **Signal Alignment:** You can select **Rising Edge** or **Falling Edge**.
- **PreDivider:** The input signal first enters the pre-divider module, which reduces source signal frequency via integer division, and then the signal is sent to the Multiplier module. The pre-divider module reduces periodic jitter on the input signal, and signals above 100 kHz must go through this module to reduce the frequency for the multiplier can only receive signals in the range of 10 kHz to 100 kHz frequency range.
- **Multiplier:** After the signal is processed by the pre-divider, it is sent to the multiplier. The multiplier multiplies the signal by an integer to increase its signal frequency, and then the signal is sent to the post-divider.
- **PostDivider:** It reduces signal frequency via an integer factor, and uses the newly generated frequency signal as the device's trigger signal.

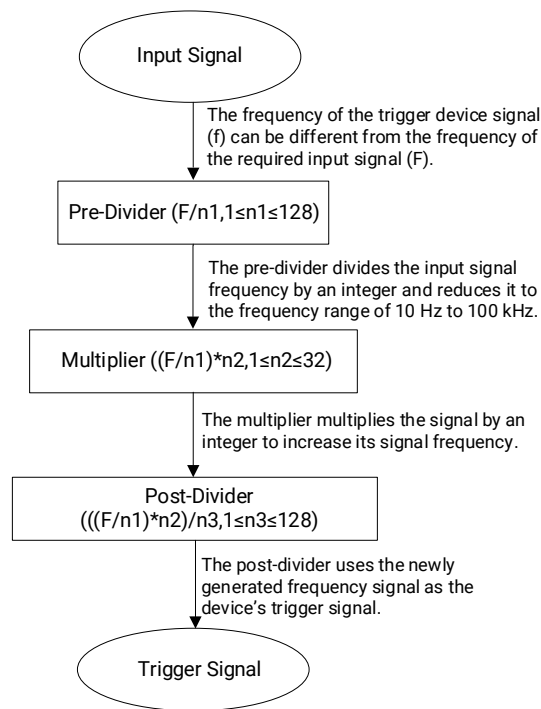

Figure 8-8 Frequency Converter Process

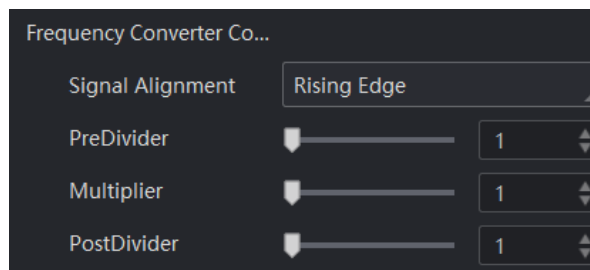

Figure 8-9 Frequency Converter Control

Encoder Control

After processed by the encoder, the device receives the trigger signal converted from signal A and signal B with phase difference. The encoder logics is shown below.

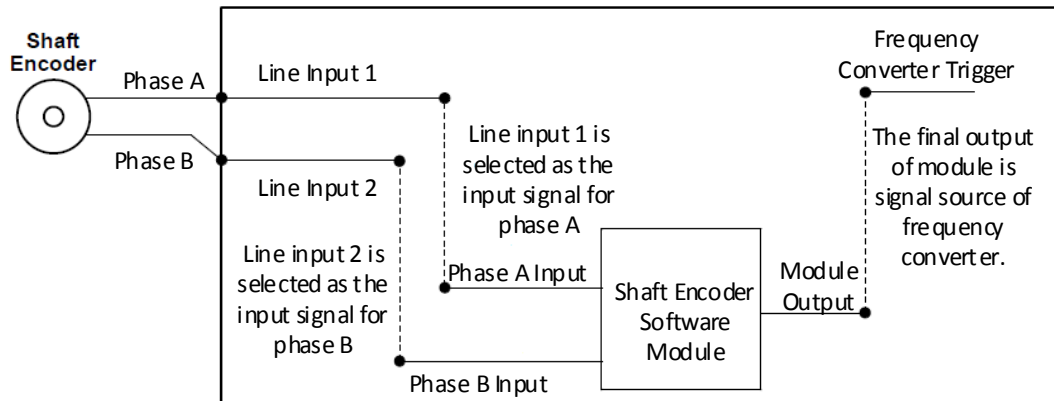

Figure 8-10 Encoder Logics

Note

It is recommended to select **Line 3** and **Line 6** for source A and source B respectively.

Steps

1. Set **Encoder Output Mode**.

- **Any Direction** means that both forward and backward direction will trigger.
- **Forward Only** mean that only forward direction will trigger.
- **Backward Only** mean that only backward direction will trigger.

2. Set **Encoder Counter Mode**.

- **Ignore Direction** means that both forward and backward direction will count.
- **Follow Direction** means that the forward direction is valid, and **Encode Counter** will increase.
- **Backward Direction** means that the backward direction is valid, and **Encode Counter** will increase.

3. (Optional) Set max. counter value in **Encoder Counter Max**.

Note

After reaching the max. value, it will be cleared automatically or you can clear manually by clicking **Execute** in **Encoder Counter Reset**.

4. (Optional) Set **Encoder Max Reverse Counter** to avoid outputting images if the object moves backward accidentally during measurement, and click **Execute** in **Encoder Reverse Counter Reset** to let the device to output images again.

5. (Optional) When the device receives external trigger signals, signal bounce may occur and cause false trigger. Thus, it is necessary to debounce trigger signals. You can select a signal in **Encoder Debouncer Selector**, and set **Encoder Debouncer Time**.

If the configured debouncer time is larger than the time of trigger signal, the trigger signal will be ignored.

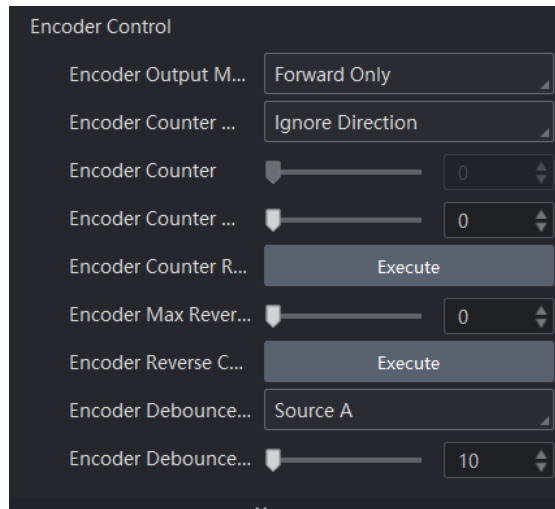

Figure 8-11 Encoder Control

8.2 Acquisition Range Advanced Settings

8.2.1 Set Measurement Range

You can set measurement range in Z direction via setting ROI, shield region, and effective region.

Set ROI

The device supports setting ROI (Region of Interest) that allows the device to acquire and measure images in specific area for improving the device's frame rate.

Note

Currently, the device's ROI mode has 3 types, including **Full**, **Middle**, and **Small**. In different modes, the vertical resolution and image's vertical coordinates may differ.

You can select **Custom** to set ROI based on actual demands if the existing 3 types of ROI mode do not meet your requirements.

Steps

1. Click  on the control toolbar to switch to the original image mode.

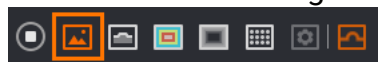









Figure 8-12 Original Image Mode

2. Click  on the control toolbar to start acquisition.

3. Go to **Camera** → **Acquisition Range Advanced Settings** → **Measurement Range Settings** → **Draw ROI**, click  to draw the ROI in the live view area, and click  to finish drawing.

Note

- You can click  to cancel drawing, click  to make the ROI in the center of the live view area, or resize the ROI window.
 - When the shield region is not in the ROI, it will not be displayed.
-

4. (Optional) Click  to adjust existing ROI.
5. (Optional) Click  to delete the ROI and restore to the full screen.

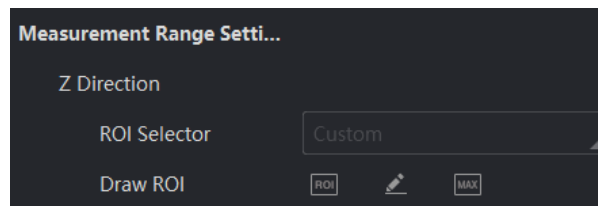

Figure 8-13 Draw ROI



Set Shield Region

When there is a light in the ROI, it may affect the measurement accuracy. You can avoid interference by setting the shield region to eliminate the measurement error caused by the light.

Note

- The validity of the shield region function depends on the internal files of the device, and the parameters cannot be saved in the user set parameter.
 - If the light appears in the range of the measured object, the use of shield region function may also cause effective data to be filtered. It is recommended to use this function with caution.
 - Up to 10 shield regions can be drawn, and you can draw 10 sides in a shield region at most.
 - If the shield region and effective region are available at the same time, only the shield region in the effective region is valid.
-

Steps

1. Click  on the control toolbar to switch to the original image mode.
2. Click  on the control toolbar of the client software to start acquisition.
3. Go to **Camera** → **Acquisition Range Advanced Settings** → **Measurement Range Settings** → **Draw Shield**, and click .
4. Click in the image to decide the starting point, drag the cursor to draw line, and double click to create a closed polygon area.

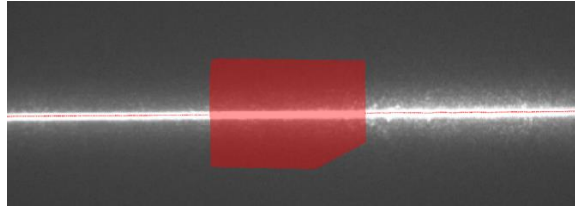



Figure 8-14 Shield Region

5. (Optional) Click  to clear drawing.
6. Click  to upload to the device after drawing.

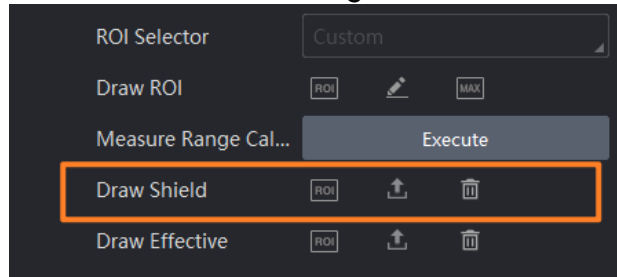

Figure 8-15 Draw Shield Region



Set Effective Region

You can draw an effective region if there is interference of light in measurement area to ensure effective data is not filtered.

Note

- The validity of the effective region function depends on the internal files of the device, and the parameters cannot be saved in the user set parameter.
- Up to 3 effective regions can be drawn, and you can draw 10 sides in an effective region at most.

Steps

1. Click  on the control toolbar to switch to the original image mode.
2. Click  on the control toolbar of the client software to start acquisition.
3. Go to **Camera** → **Acquisition Range Advanced Settings** → **Measurement Range Settings** → **Draw Effective**, and click .
4. Click in the image to decide the starting point, drag the cursor to draw line, and double click to create a closed polygon area.

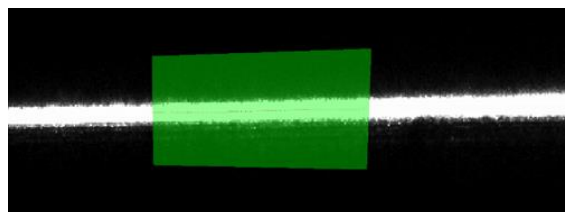



Figure 8-16 Effective Region

5. (Optional) Click  to clear drawing.
6. Click  to upload to the device after drawing.

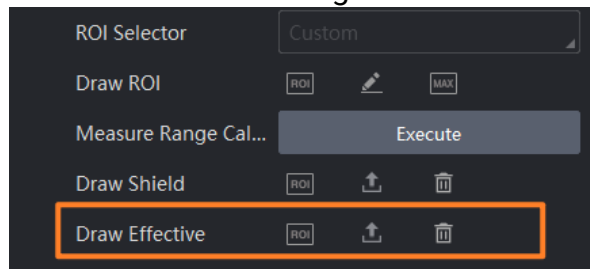

Figure 8-17 Draw Effective Region

8.2.2 Set Binning

The purpose of binning is to enhance sensibility. With binning, multiple sensor pixels are combined as a single pixel to reduce resolution and improve image brightness. Go to **Camera** → **Acquisition Range Advanced Settings** → **Binning Settings** and set it.

Note

- This function may differ by the device model. Refer to the actual device you got.
 - Currently, the device supports 2 × 1 binning only.
-

8.2.3 Set Capture Area

You can set the following parameters to configure the capture area in Y direction.

Table 8-5 Capture Area Parameters

Parameter	Description
Downsampling Enable	After this parameter is enabled, the device selects one pixel from multiple adjacent pixels, reducing output resolution. It is valid in X direction only.
Range Image Height	It sets the profile quantity of a depth image, and the unit is pixel.
X Range	It refers to the measurement range in the depth image's X direction, and the unit is μm .
X Offset	It refers to the deviation in X direction from depth image origin point, and the unit is μm . It should be set when absolute measurement is performed.
Y Offset	It refers to the deviation in Y direction from depth image origin point, and the unit is μm . It should be set when absolute measurement is performed.
Z Offset	It refers to the deviation in Z direction from depth image origin point, and the unit is μm . It should be set when absolute measurement is performed.

Update Measure Range And Scale	After drawing the ROI, you can click Execute in here, and the device will automatically calculate and set X/Y/Z offset and X range.
--------------------------------	--

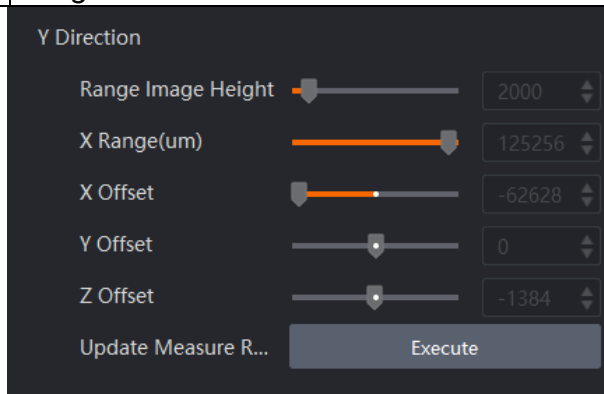

Figure 8-18 Set Capture Area

Chapter 9 Shot Feature Parameters

Note

The related parameters may differ by device model and firmware version.

9.1 Light Intensity Settings

You can set light intensity according to the actual demands. Go to **Shot Feature** and set **Light Intensity Settings**. The parameters are shown below.

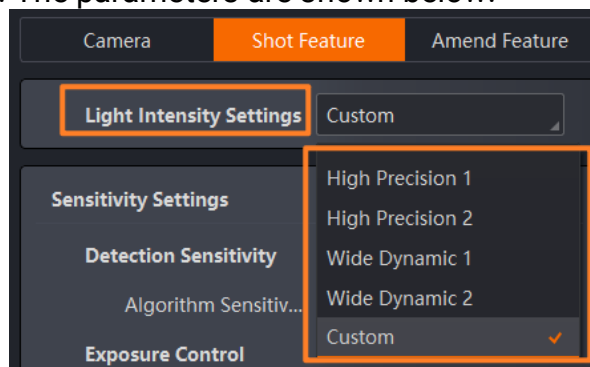

Figure 9-1 Light Intensity Settings

Table 9-1 Parameters of Light Intensity

Parameters	Description
High Precision 1	It is applicable for diffuse reflection or highly reflective materials with high profile precision. <ul style="list-style-type: none"> ● Exposure mode: Single ● Exposure time: 100 μs ● Gain: 0 dB ● Filter parameter: Disabled
High Precision 2	It is applicable for materials with low reflectivity, such as metal, and high profile precision. <ul style="list-style-type: none"> ● Exposure mode: Single ● Exposure time: 200 μs ● Gain: 3 dB ● Filter parameter: Enabled, and its value is fixed.
Wide Dynamic 1	It is applicable for scenes with some differences in materials, and has high profile integrity. <ul style="list-style-type: none"> ● Exposure mode: Multiple ● Exposure time: 50 μs / 100 μs / 150 μs ● Gain: 0 dB / 3 dB / 5 dB

	<ul style="list-style-type: none"> • Filter parameter: Enabled, and its value is fixed.
Wide Dynamic 2	<p>It is applicable for scenes with large differences in materials, and has high profile integrity.</p> <ul style="list-style-type: none"> • Exposure mode: Multiple • Exposure time: 50 μs / 150 μs / 250 μs • Gain: 0 dB / 3 dB / 5 dB • Filter parameter: Enabled, and its value is fixed.
Custom	Set exposure mode, gain, and filter parameter manually.

9.2 Sensitivity Settings

9.2.1 Set Detection Sensitivity

You can set the following parameters to adjust the detection sensitivity for accurate extraction result of laser center line in the original image.

Table 9-2 Parameters of Detection Sensitivity

Parameters	Description
Algorithm Sensitivity	<p>There are four modes.</p> <ul style="list-style-type: none"> • Wide mode: <ul style="list-style-type: none"> Min. line width: 1 Max. line width: 200 Binary threshold: 10 Gradient threshold: 2 • Medium mode: <ul style="list-style-type: none"> Min. line width: 1 Max. line width: 40 Binary threshold: 20 Gradient threshold: 10 • Narrow mode: <ul style="list-style-type: none"> Min. line width: 2 Max. line width: 20 Binary threshold: 30 Gradient threshold: 30 • Custom mode: Set min. line width, max. line width, binary threshold, and gradient threshold manually.
Min/Max Line Width	<p>It is valid when the pixel quantity occupied by continuous laser lines in vertical direction is larger than or equal to min. line width and is smaller than or equal to max. line width.</p> <p>If Custom is selected as Algorithm Sensitivity, you can set the value. It is recommended to set 1 as the min. line width, and the</p>

	max. value cannot exceed 255.
Binary Threshold	The device only selects the pixel points of laser lines whose gray value is larger than or equal to this parameter. If Custom is selected as Algorithm Sensitivity , you can set the value. When the overexposure is severe, increasing the value is recommended.
Gradient Threshold	The device will search for laser line pixel points nearby only when the absolute value of the gray gradient is greater than or equal to the gradient threshold. If Custom is selected as Algorithm Sensitivity , you can set the value.
Halo Gray Threshold	It is used for calculate the halo width, which is the number of pixels exceeding halo threshold. If the halo width is greater than the max. laser line width, the laser center point in the halo will be regarded as the noise and will not be extracted. 
Brightness Fusion	You can set brightness fusion to adjust the brightness of the image. This function can adjust the brightness of the laser line by adjusting the gray value of the pixels. The higher the fusion factor, the brighter the laser line is.  

Figure 9-2 Halo

Figure 9-3 Brightness Fusion Off

Figure 9-4 Brightness Fusion × 2

	 <p style="text-align: center;">Figure 9-5 Brightness Fusion × 4</p> <p>Note It is recommended to adjust brightness fusion first, and then adjust the exposure.</p>
<p>Brightness Calculation Weight</p>	<p>Weight0/4 can be selected. The lower the value, the darker and smoother the image is.</p>
<p>Row Convolution Template</p>	<p>Convolution1/2/3/4 can be selected. The larger the value of convolution, the greater the distortion of the laser center point results, and the more severe the laser line edge warping, but the greater the vibration resistance will be.</p> <div style="display: flex; justify-content: space-around; align-items: center;">   </div> <p style="text-align: center;">Figure 9-6 Row Convolution</p>
<p>Col Convolution Template</p>	<p>Convolution1/2/3/4 can be selected. The larger the value of convolution, the stronger the filtering effect, and the weaker the device's ability to distinguish laser line adhesion, and the stronger the noise resistance.</p>

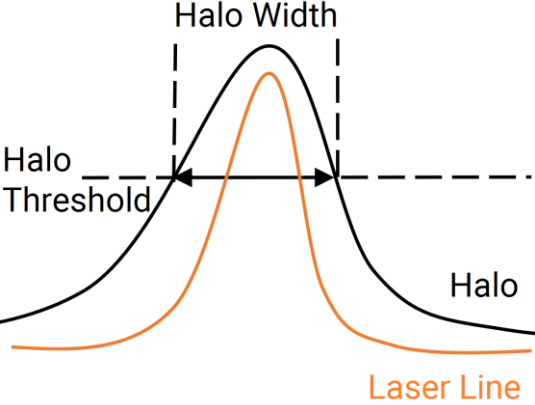
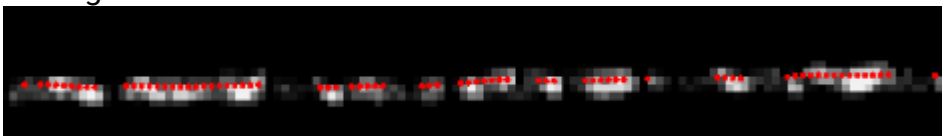
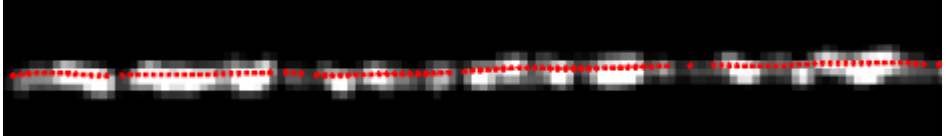
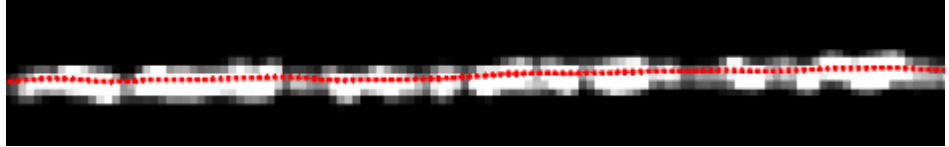
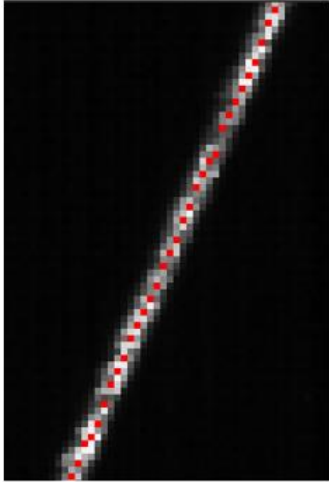
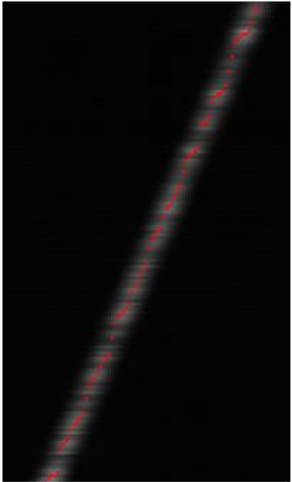
9.2.2 Set Single Frame HDR

After you enable the single frame HDR, multi-exposure fusion, overexposure control, and dynamic range improvement will be executed within a frame.

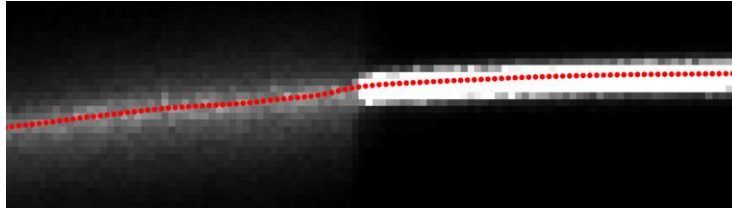

Figure 9-7 Single Frame HDR Disabled

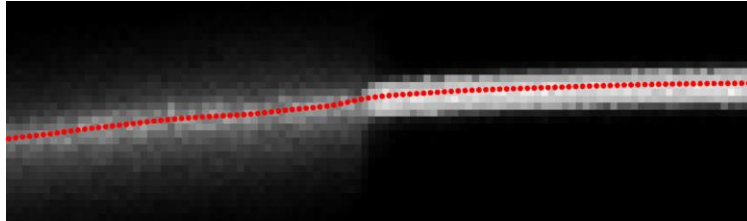

Figure 9-8 Single Frame HDR Enabled

If **Custom** is selected as light intensity, you can go to **Shot Feature** → **Sensitivity Settings** to enable **Single Frame HDR**, and set level of wide dynamic. The higher the level, the stronger the ability for overexposure suppression.

 **Note**

- This function is available for some device models. Refer to the actual device you got.
 - This function is supported when the exposure mode is single.
-

9.2.3 Set Exposure Mode

You can set exposure mode according to the actual demands. Make sure the **Custom** is selected as light intensity.

Go to **Shot Feature** → **Sensitivity Settings** → **Exposure Control**, and set **Exposure Mode**. The device supports 2 types of exposure mode, including single and multiple.

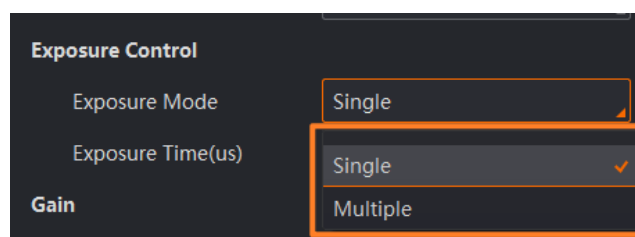

Figure 9-9 Set Exposure Mode

- If **Single** is selected as **Exposure Mode**, you can enter **Exposure Time** according to actual demands.

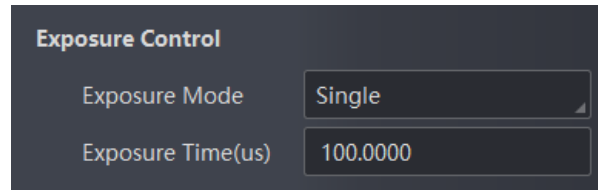

Figure 9-10 Single Exposure Mode

- If **Multiple** is selected as **Exposure Mode**, you can enter 2 sets of exposure time. The device will automatically acquire images based on the parameters you configured.

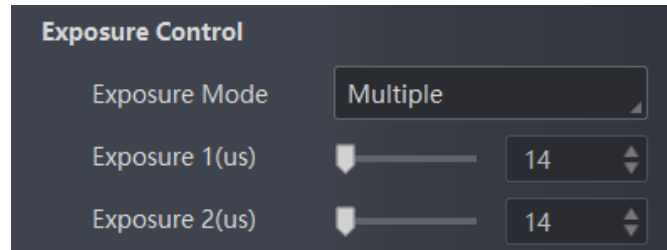

Figure 9-11 Multiple Exposure Mode of DP2000 Series Device

9.2.4 Set Gain

You can select Gain 1x/2x/3x/4x. The higher the gain level, the brighter the image will be. At the same time, the image noise will increase, which will affect the image quality.

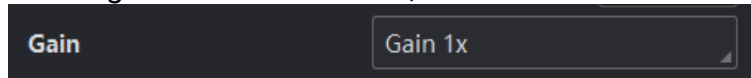

Figure 9-12 Set Gain

9.2.5 Set Light Intensity Control

Caution

The safety class of the device's laser is Class 2, Class 3B or Class 3R. Do not observe the device's laser module to avoid eye damage.

The device's laser is used to send laser lines to the measured object. For normal use of the device, you need to enable the laser.

Go to **Shot Feature** → **Sensitivity Settings** → **Light Intensity Control**, and enable **Laser Enable**. You can also set laser ratio via **Lower Limit** and **Upper Limit**. The laser ratio refers to the percentage of the laser turn-on time to the total laser cycle time.

After adjustment, you can view laser ratio in **Laser Light Current View**.

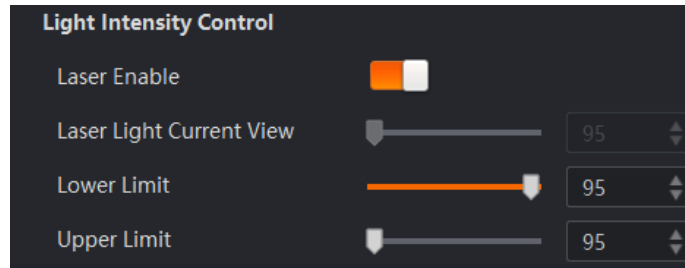

Figure 9-13 Set Laser Ratio

Note

When the exposure mode is **Multiple**, the laser adjustment is not supported.

9.3 Interference Removal

9.3.1 Set Point Select Mode

You can set the following parameters to remove noise.

Table 9-3 Parameters of Interference Removal

Parameters	Description
Point Select Mode	<p>If the device extracts multiple laser points from one column in the image, you can select different point modes to extract effective laser points. Point mode includes Best, Top, Bottom, Widest, Nearest, and Farest.</p> <ul style="list-style-type: none"> • Best: If multiple laser points are extracted from the same column, select the point with the largest average gray level; if the average gray level is the same, select the point with the largest line width; if the average gray level and line width are the same, select the point with the highest pixel brightness; if the average gray level, line width and the brightest value are the same, then select the top point. The Best is recommended for the general scene. • Top: When more than one laser point is extracted from the same column, select the top laser point. • Bottom: When multiple laser points are extracted from the same column, select the bottom laser point. • Widest: When multiple laser points are extracted from the same column, select the point with the largest line width; if the line widths are the same, the brightest point with the same line width is preferred; if the line widths are the same, and the brightest values of the laser lines are also the same, then select the center point of the laser line with the highest average brightness.

	<ul style="list-style-type: none"> ● Nearest: Set Gray Threshold Sub first. If the average gray level of 2 laser points is higher than the threshold, the closest laser point is preferred; if the average gray level of 1 of the laser points is lower than or equal to the threshold, the brighter one is selected. ● Farest: Set Gray Threshold Sub first. If the average gray level of 2 laser points is higher than the threshold, the farthest laser point is preferred; if the average gray level of 1 of the laser points is lower than or equal to the threshold, the brighter one is selected.
Cost Select Point Enable	After the function is enabled, the continuity and integrity of the laser line center point are optimized.

9.3.2 Set Noise Filter

Continuity Filtration

The device supports continuity filtration to remove noise.

Table 9-4 Continuity Filtration Parameters

Parameters	Description
Continuity Open Enable	After the function is enabled, the noise will be removed.
Continuity Mode Selector	<p>You can select Aggressive, Moderate, Mild, and Custom.</p> <ul style="list-style-type: none"> ● Aggressive: Window size: 16 Thick threshold: 3 Height threshold: 1 ● Moderate: Window size: 8 Thick threshold: 3 Height threshold: 2 ● Mild: Window size: 4 Thick threshold: 3 Height threshold: 8 ● Custom: It can segment the laser line by the height difference or line width difference of adjacent points. The laser segments smaller than the window size will be removed.
Continuity Window Size	When Custom is selected as Continuity Mode Selector , you can set the parameter.

	It sets the continuous filtering window size. The laser segments smaller than the window size will be removed.
Continuity Thick Threshold	When Custom is selected as Continuity Mode Selector , you can set the parameter. It sets the continuous filtering thickness threshold. If the line width difference of adjacent laser points is larger than this value, the segmentation will be performed.
Continuity Height Threshold	When Custom is selected as Continuity Mode Selector , you can set the parameter. It sets the continuous filtering height threshold. If the height difference of adjacent laser points is larger than this value, the segmentation will be performed.

Average Gray Calculate Control

The device supports setting two ratios of average gray to improve image brightness.



Figure 9-14 Average Gray Calculate Control

The diagram of two ratios of average gray is shown below. The X-axis refers to the original average gray, and the Y-axis refers to two ratios of average gray.

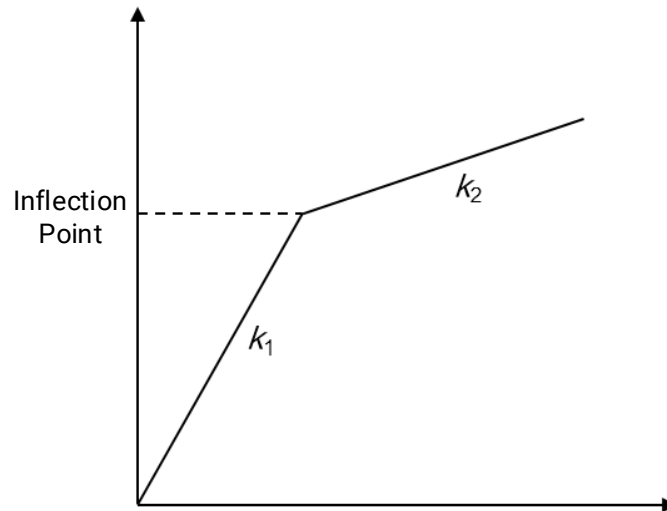

Figure 9-15 Average Gray Calculate Control

Table 9-5 Average Gray Calculate Control Parameters

Parameters	Description
Average Gray Calculate	It refers to the Y-axis of the inflection point of two lines.
Average Gray Main Ratio	It refers to the ratio of the first line (from the original point to the inflection point).
Average Gray Sub Ratio	It refers to the ratio of the second line (from the inflection point to the end point).

9.4 X Axis Invalid Data Process

The device supports center data filling to fill the invalid data.

Table 9-6 Parameters of X Axis Invalid Data Process

Parameters	Description
Invalid Center Data Fill Enable	After this function is enabled, for the invalid data that meet the window and threshold requirements, the data will be filled by connecting the valid laser point lines on both sides.
Invalid Center Data Fill Window Size	It sets the width of the invalid data fill window. The invalid data smaller than this width can be filled.
Invalid Center Data Fill Threshold	It sets the invalid data filling threshold. The invalid data can be filled when the slope of the valid laser lines on both sides is less than this value.

Chapter 10 Amend Feature Parameters

Note

The related parameters may differ by device model and firmware version.

10.1 Image Output Settings

The device supports setting parameters for outputted depth images. Refer to the figure and table below for details.

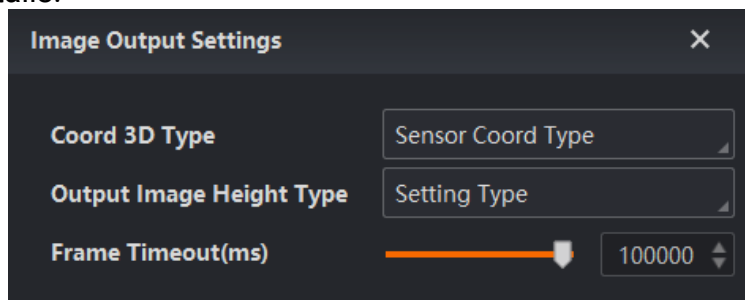



Figure 10-1 Image Output Settings

Table 10-1 Parameters of Image Output Settings

Parameters	Description
Coord 3D Type	<p>It sets the coordinate's three-dimensional type, including sensor coord type, system coord type, and rotation coord type.</p> <ul style="list-style-type: none"> • Sensor coord type: It is a coordinate type that is set from the factory. • System coord type: It is a coordinate type that the line, static, or dynamic calibration are executed for the device. • Rotation coord type: It is a coordinate type that the rotation calibration is executed for the device. <p> Note Before system calibration, you need select Sensor Coord Type as Coord 3D Type.</p>
Output Image Height Type	<p>It selects height output mode for the depth image, including real type and setting type.</p> <ul style="list-style-type: none"> • Real type: After trigger is completed, the device outputs depth images based on actual profile quantity. If the actual profile quantity is larger than the range image height, then the device will output according to the range image height. • Setting type: After trigger is completed, the device outputs

	depth images based on range image height. If the actual profile quantity is larger than range image height, then the device will output according to the range image height. The black-fill will be performed on the exceeding part for outputting. This mode is recommended for the general condition.
Frame Timeout	<p>It sets the device's trigger stopping time.</p> <ul style="list-style-type: none"> • If it is 0, the device will wait for the next trigger signal until the height matches with the range image height, and then output the image. • If it is not 0 and the device does not receive next trigger signal within configured time, the trigger is stopped. At this point, the image will be outputted after black-fill, and the image height is range image height.

10.2 Filter Settings

The device supports setting filter window and filtering profile points.

Table 10-2 Profile Filter Parameters

Parameters	Description
Mean Filter Window Size	<p>It is a mean filter window size. 3/5/7/9 point or OFF can be selected.</p>  <p style="text-align: center;">Figure 10-2 Mean Filter</p>
Median Filter Window	It is a median filter window size. 3/5/7/9 point or OFF can be

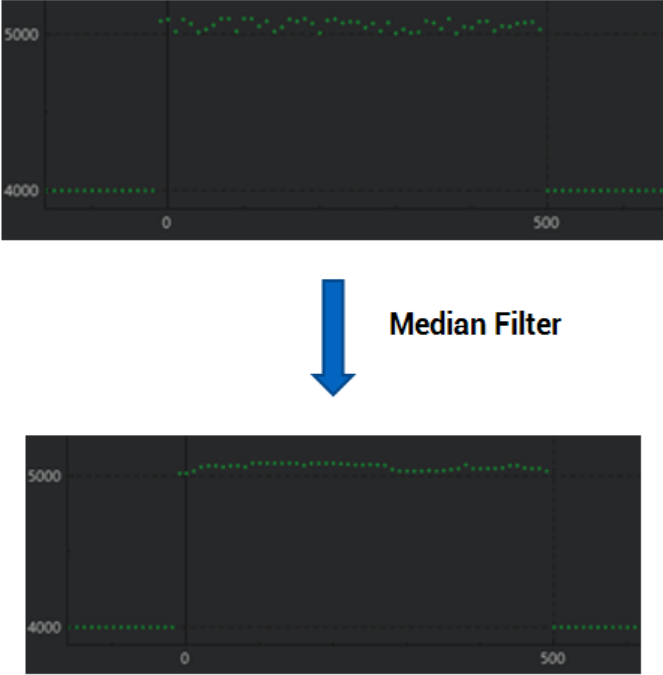
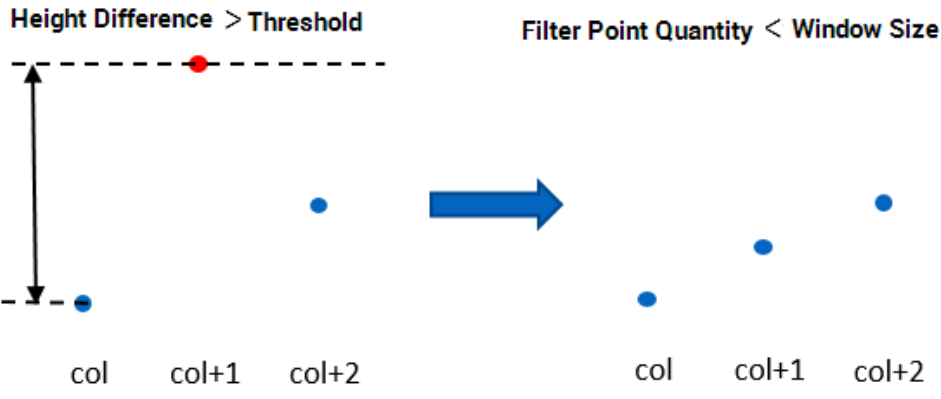
<p>Size</p>	<p>selected.</p>  <p>Figure 10-3 Median Filter</p>
<p>Outliers Filter Window Size</p>	<p>It is an outliers filter window size. 3/5/7/9 point or OFF can be selected.</p> <p>Height Difference > Threshold Filter Point Quantity < Window Size</p>  <p>Figure 10-4 Outliers Filter</p>

Note

For the single frame, the filtering can be executed once. For the multiple frames, the filtering can be executed once in the column direction across frames.

Chapter 11 I/O Electrical Feature and Wiring

11.1 I/O Electrical Feature

11.1.1 Differential Input Circuit

The device's Line 0/3/6 are differential input signals that support single-ended input. The internal circuit of Line 0/3/6 is shown below.

Note

For DP2000/DP3000 V2.0 series devices, only Line3/6 are differential input signals.

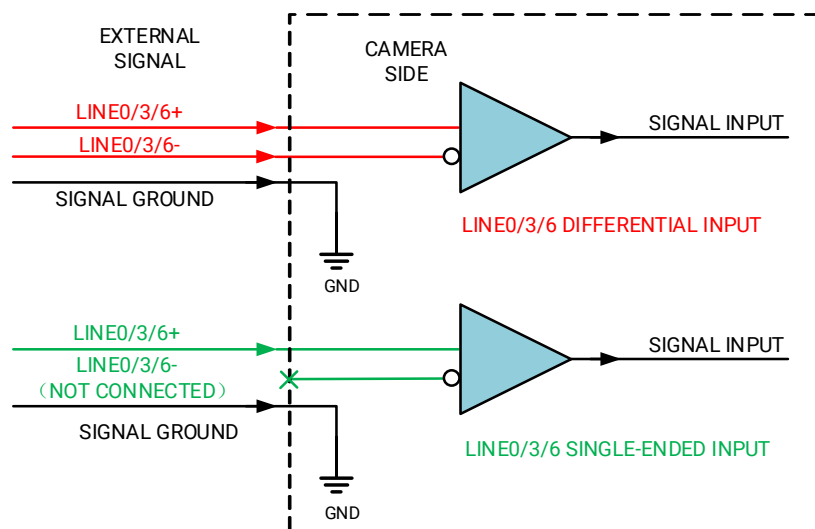

Figure 11-1 Differential Input Circuit

The RS-422 standard and TTL & LVTTTL standard input signal are applied to the differential input.

- RS-422 Standard Input

In order to make sure the normal operation of input circuit, it is required to connect device's ground signal with external ground signal if the differential input adopts RS-422 standard signal.

RS-422 standard defines the connection of the bus structure, and the inputs of several devices can be connected to the RS-422.

Up to 10 devices can be connected at the same time, of which only one device is the main dispenser and other devices are receivers. The circuit length between the receiver and the bus should be as short as possible. The bus must have a 120 Ω terminal resistance.

When the device is the last receiver on the bus structure, the device's terminal resistance

needs to be enabled, and the rest devices' terminal resistance need to be disabled. Multiple terminal resistance should not be enabled on the bus structure, which will reduce signal reliability and may cause damage to the RS-422 device.

- TTL & LVTTTL Standard Input

If the differential input adopts TTL & LVTTTL standard signal, the input terminal's 120 Ω terminal resistance must be disabled, and its input electrical feature requirement is shown below.

Table 11-1 Electrical Feature Requirements

Voltage Range	Definition
0 V to 1.1 V	Level low
3.2 V to 5 V	The voltage is not stable, and it is recommended not to use.
5 V to 24 V	Level high

11.1.2 Differential Output Circuit

The device's Line 1 is differential output signal, and its internal circuit is shown below.

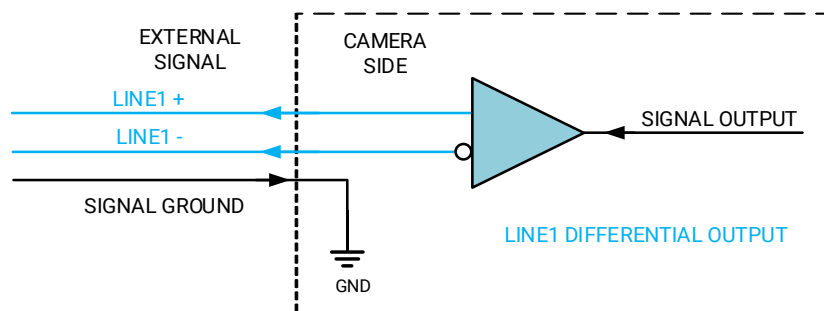

Figure 11-2 Differential Output Circuit

In order to make sure the normal operation of output circuit, it is required to connect device's ground signal with external ground signal. The interface can be connected to the RS-422 bus structure as a main dispenser.

11.1.3 Opto-Isolated Input Circuit

The LineIn 0/9 of the DP2000/DP3000 V2.0 series devices are opto-isolated input signals, and internal circuit is shown below.

 **Note**

- The input voltage is from 5 VDC to 24 VDC.
- The breakdown voltage is 36 VDC. Keep voltage stable.

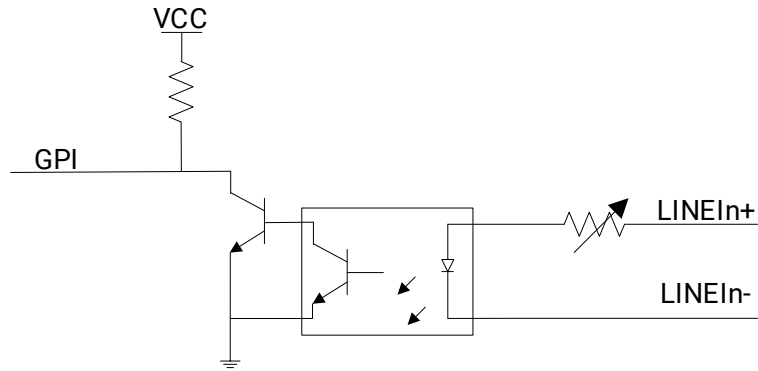

Figure 11-3 Internal Circuit of Input Signal

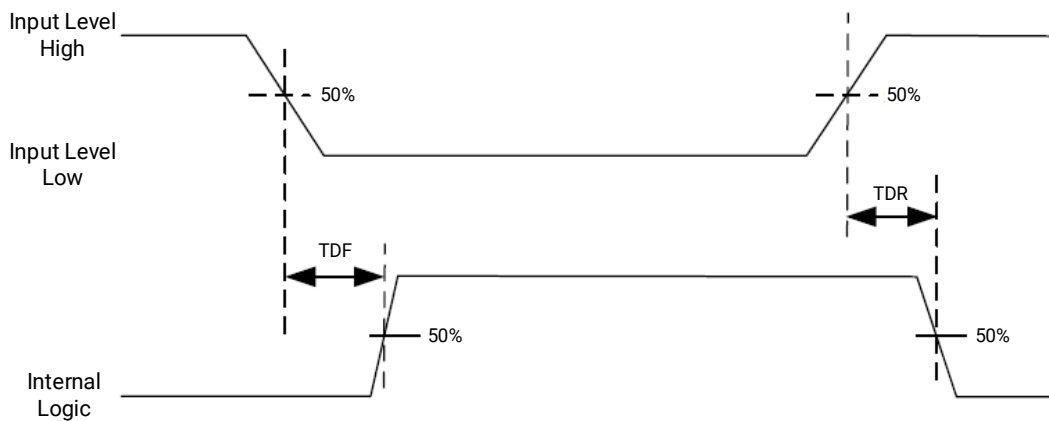

Figure 11-4 Input Logic Level

The electrical features of opto-isolated input is shown below.

Table 11-2 Input Electrical Feature

Parameter Name	Parameter Symbol	Value
Input Logic Level Low	VL	1.5 VDC
Input Logic Level High	VH	4 VDC
Input Falling Delay	TDF	81.6 μ s
Input Rising Delay	TDR	7 μ s

11.2 Device Wiring

11.2.1 Differential Input Wiring

The device can be connected to an encoder via differential input signals to trigger and acquire images. The device's Line 0/3/6 can receive differential signals or single-ended signals.

Note

- For DP2000/DP3000 V2.0 series devices, only Line3/6 are differential input signals.
- When there is a large amount of interference in the field and the I/O signal interference occurs, it is necessary to perform signal grounding of the idle signals.

Differential Signal

The electrical feature and wiring of the differential signal are shown below.

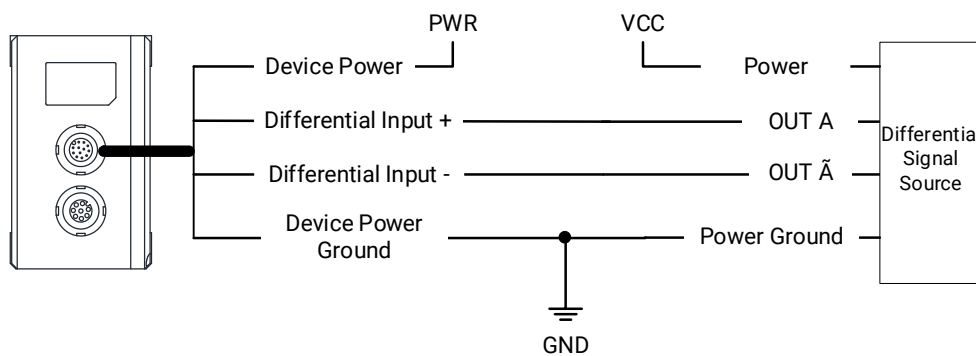

Figure 11-5 Differential Signal Source

Table 11-3 Electrical Feature of Differential Signal

Parameter Name	Description
Max. Voltage	24 V
Level Threshold	Low level: < 0.2 V High level: > 0.2 V

Single-Ended Signal

The electrical feature and wiring of the single-ended signal are shown below.

Table 11-4 Electrical Feature of Single-End Signal

Parameter Name	Description
Max. Voltage	30 V
Level Threshold	Low level: < 1.3 V High level: > 1.7 V

If PNP single-ended signal source provides the differential input signal, and differential input signal is used as single-ended input, its wiring is shown below. The VCC of PNP type single-ended signal source is 5 VDC, 12 VDC, or 24 VDC.

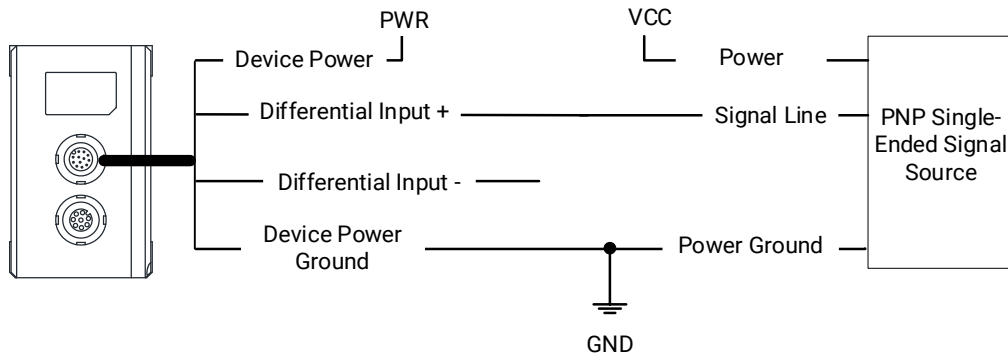

Figure 11-6 PNP Single-Ended Signal

If NPN single-ended signal source provides the differential input signal, and differential input signal is used as single-ended input, its wiring is shown below. The VCC of NPN type single-ended signal source is 5 VDC, 12 VDC, or 24 VDC.

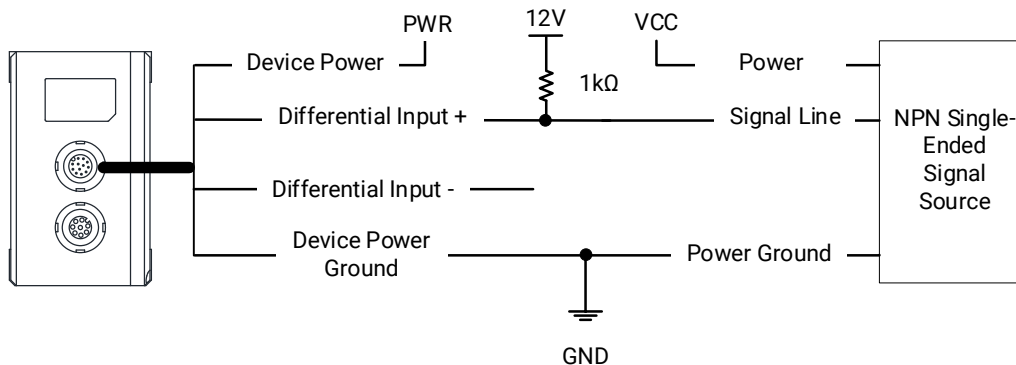

Figure 11-7 NPN Single-Ended Signal

Note

- For single-ended signal, the Differential Input - of the device should be suspended, and it is recommended that the suspended wire should be closed with an insulating cap.
- When VCC of single-ended signal source is 24 V, and it is connected to switch input, a 5.1 KΩ resistor should be added in the power circuit.

11.2.2 Opto-Isolated Input Wiring

The DP2000/DP3000 V2.0 series devices can connect to the external devices via opto-isolated input signal Line 9.

Note

Input signal wiring may differ with different types of external devices.

PNP Device

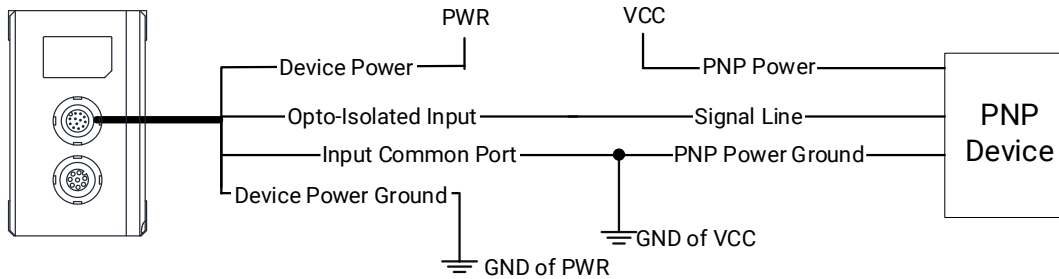

Figure 11-8 Input Signal Connecting to PNP Device

NPN Device

If the VCC of NPN device is 12 VDC or 24 VDC, it is recommended to use a 1 K Ω pull-up resistor with power exceeding 0.2 W.

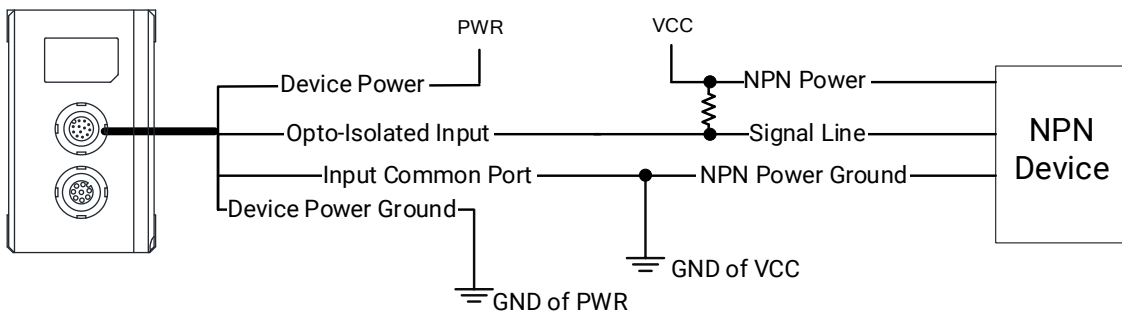

Figure 11-9 Input Signal Connecting to NPN Device (With Pull-Up Resistor)

If no pull-up resistor is used, the wiring is shown below.

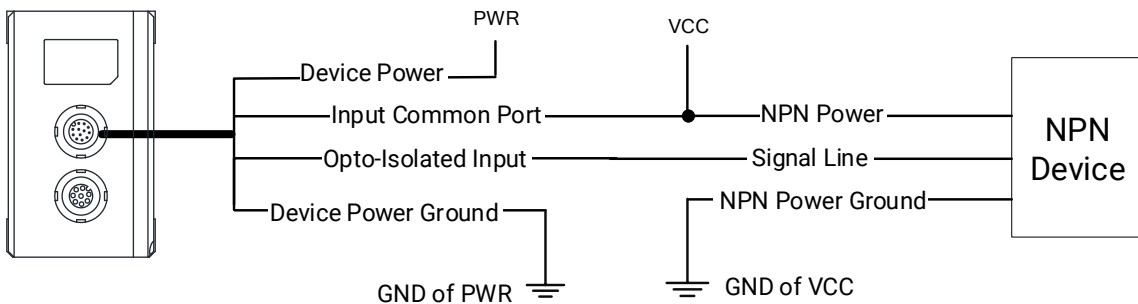

Figure 11-10 Input Signal Connecting to NPN Device (Without Pull-Up Resistor)

Chapter 12 Device Calibration

Errors may occur during the device installation process, which may affect the accuracy of outputted data. These errors can be corrected via system calibration. At the same time, calibrate the scanning direction and speed to get the point cloud data in the system coordinates.

12.1 Preparation

Before performing system calibration, the following preparations should be done.

- Make sure that the profile of laser lines on the measured objects are clearly visible. You can check if the current profile data is correct via the client software.
- Complete the ROI settings, and the horizontal range, min. height and max. height values of measured objects should be within the ROI. At the same time, the ROI should not be too large for the consideration of the device's frame rate. Refer to the section [Set Measurement Range](#) for details.

Note

When performing the dynamic calibration, laser lines on datum plane are not needed. Otherwise, the calibration result may be inaccurate.

12.2 System Calibration

The system calibration can correct the installation deviation and datum plane of the device, and get the three-dimensional data in the system coordinate system.

System calibration is divided into line calibration, static calibration, dynamic calibration, and rotation calibration. For multi-camera scene, dynamic stitching calibration and static stitching calibration are also available. Different calibration methods are suitable for different scenarios.

- **Line calibration** is used to correct the profile and flatten it to Z=0 plane.
- **Static calibration** is applicable for obtaining the surface of the rotating body, that is, the relative position of the device and measured objects is not changed.
- **Dynamic calibration** is applicable for measuring the profile of objects on the linear conveyor belt, that is, the relative position of the device and measured objects is changed.
- **Rotation calibration** is applicable for rotating platform and other motion systems, such as turntable inspection scenes. It can correct the image distortion caused by the inconsistency of the line speed of the object at different positions on the turntable, and further correct the error in the direction of rotation on the basis of static calibration.
- **Dynamic stitching calibration** is used when relative movement exists between the multiple cameras and calibration object, to realize the unification of the coordinate system of multiple cameras based on the physical dimension of the calibration object. Special

calibration object should be used.

- **Static stitching calibration** is used when the profile data of calibration object is obtained by multiple cameras, to realize the unification of the coordinate system of multiple cameras based on the physical dimension of the calibration object. Special calibration object should be used.

Note

- The system calibration has an angle limitation. If the angle is too large, it may result in calibration result error.
 - Refer to the ***3DMVS Client Software User Manual*** for details.
-

Chapter 13 Other Functions

13.1 Feature Save

The device supports 11 sets of parameters, including 1 default set and 10 user sets. The relation among 11 sets of parameters is shown below.



Figure 13-1 Parameter Relation

You can save parameters, load parameters, rename parameters, and set user default as shown below.

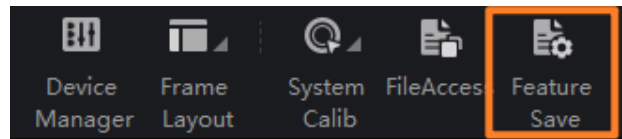

Figure 13-2 Feature Save

Note

After settings, it is recommended to save the parameter and set the parameter as the default to avoid the device restoring to its default settings after restarting.

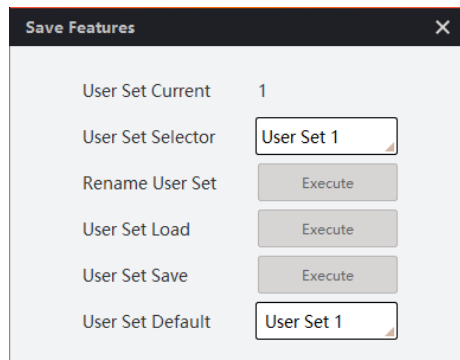

Figure 13-3 Parameters of Feature Save

- **Save Parameters:** Select a user set (Default excluded) in **User Set Selector**, and click **Execute** in **User Set Save** to save parameters. Here we take selecting **User Set 1** as an example.
- **Load Parameters:** Select a user set (Default included) in **User Set Selector**, and click **Execute** in **User Set Load** to load parameters to the device. Here we take selecting **User Set 1** as an example.

Note

Loading parameters is available when connecting to the device but without acquisition.

- **Rename User Set:** Edit the name in **User Set Selector**, and click **Execute** in **Rename User Set** to save the changes.
- **Set User Default:** Select parameter from drop-down list of **User Set Default**.

13.2 Update Firmware

The device supports updating the firmware via the client software.

Note

- Use the firmware package of the corresponding device model for updating.
 - Do not disconnect the device with PC during updating.
 - The device will restart automatically after updating.
-

Before You Start

Make sure the device is not connected and not in use.

Steps

1. Run the client software, and click **Device Manger** on the control toolbar to open the device list window.
 2. Select the device that needs to be updated.
-

Note

Make sure that the device that needs to be updated is in available status.

3. Click **Upgrade** to open the updating window.

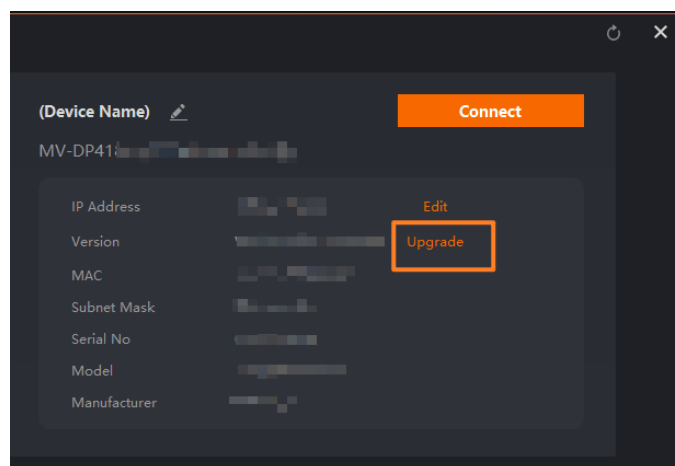



Figure 13-4 Device List Window

4. Click  to select the firmware file (dav format), and click **Upgrade** to update the firmware.

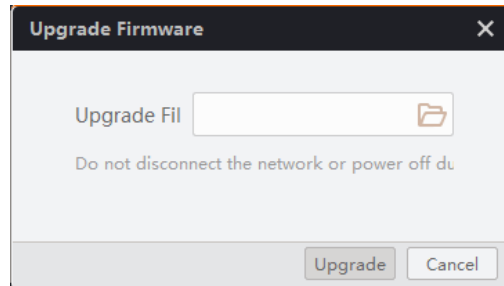

Figure 13-5 Update Firmware

13.3 File Access Control

The file access function can import or export the device's calibration files and save them in mfa format.

The device's calibration files include user set file, sensor calibration file (LSL Sensor Calibrate LUT), system calibration file (LSL System Calibrate), external dependency file (Device Extend Config), device encryption file (Device Enc File), license notice (OpenSource Notice, exporting only), and mapping file (Feature Language Map).

Steps

1. Select a device in the device list, and click **FileAccess** to open the file access dialogue box.

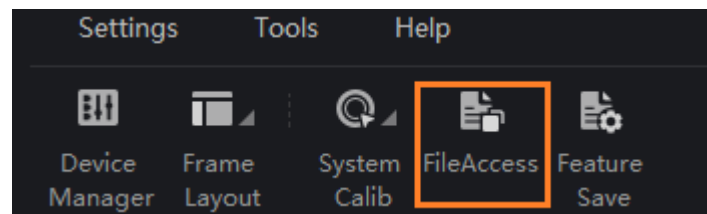

Figure 13-6 File Access

2. Select **Device Feature** and click **Import** or **Export**.

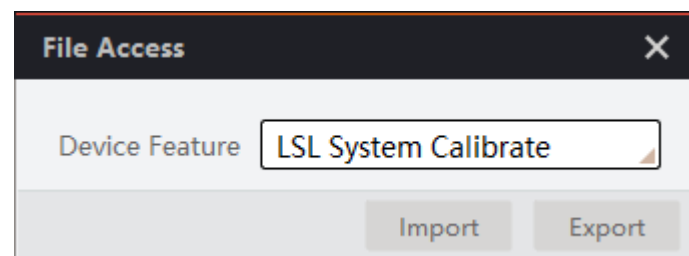

Figure 13-7 Import or Export

3. Select an mfa file from local PC to import or select a saving path and enter file name to save and export.

Chapter 14 FAQ (Frequently Asked Question)

14.1 Why there is no device listed after I run the client software?

Table 14-1 Question 1

Possible Cause	Solution
The device is powered off.	Check the device power connection to make sure the device is powered up normally.
Network exception occurs.	Check the network connection to make sure the device can be connected to the network normally. PC and the device are in the same network segment.

14.2 Why the image is very dark?

Table 14-2 Question 2

Possible Cause	Solution
The laser is not enabled.	Enable the laser.
The values of the exposure and gain are too small.	Increase the exposure and gain properly.

14.3 Why the image quality is very poor during the live view?

Table 14-3 Question 3

Possible Cause	Solution
The network may be Fast Ethernet.	Check if the network transmission speed is 1 Gbps or not.
Packet loss occurs.	Go to Settings → Resend Packet in the menu bar of the client software, enable Resend Packet , and increase Max. Packet

Possible Cause	Solution
	Resending Percent and Timeout Period properly.

14.4 Why the image is black and without the laser line in origin image mode?

Table 14-4 Question 4

Possible Cause	Solution
The position of the laser line exceeds the field of view.	Adjust the height between the device and measured object, and make sure that the object is within the measurement range.

14.5 Why fail to save images or single frame point cloud?

Table 14-5 Question 5

Possible Cause	Solution
The client software has no permission to read and write the system disk (C).	Run the client software as the administrator.
There is no profile data.	Adjust exposure and algorithm parameters.

14.6 Why exception occurs when previewing the point cloud?

Table 14-6 Question 6

Possible Cause	Solution
The configuration of video card is too low.	Use a discrete video card.
The version of video card driver is too old.	Update the video card driver.

14.7 Why depth images cannot be obtained during preview?

Table 14-7 Question 7

Possible Cause	Solution
The device has not obtained profile data.	Adjust exposure and image output parameters, and switch to the depth image after you can view profiles.
Improper parameters of depth images.	Adjust X scale parameters to let the depth image be in the center of the image.

Chapter 15 Revision History

Table 15-1 Revision History

Version	Revision Date	Revision Details
V1.0.0	Aug. 4, 2025	Original version.



HIKROBOT

SHAPE OUR FUTURE INTELLIGENTLY

Hikrobot Co., Ltd.

Tel: 400-989-7998

Website: <https://en.hikrobotics.com/>

UD42488B