

MV-DP2120-01P

3D Laser Profile Sensor



Introduction

With built-in high-accuracy algorithm, image process algorithm of wide dynamic range, and data integration algorithm, MV-DP2120-01P can output high accurate 3D point cloud data in real-time by combining high frame rate chip and accurate laser control. With compact structure, high integration, and easy operation, it is widely applied into consumer electronics, electronics manufacturing, automobile, etc.

Available Model

- MV-DP2120-01P
- MV-DP2120-01P V2.0

Applicable Industry

Consumer electronics, electronics manufacturing, automobile, etc.

Dimension

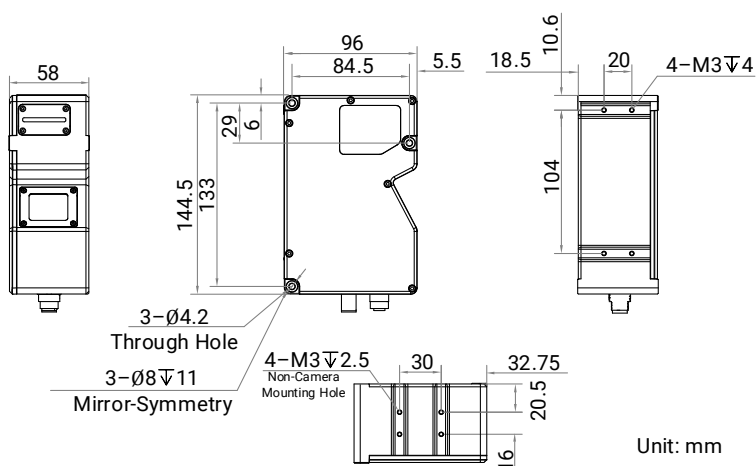

Key Feature

- Built-in high-accuracy algorithm and accuracy is up to submicron level.
- Adopts high frame rate chip with 23.9 kHz scan frame rate.
- Supports multiple exposure modes with good robustness.
- Adopts multiple-frame integration technology to provide complete profiles.
- Provides multiple filter modes with stable data.
- Supports ROI selection and auto setting for easier operation.

Measurement Range Diagram

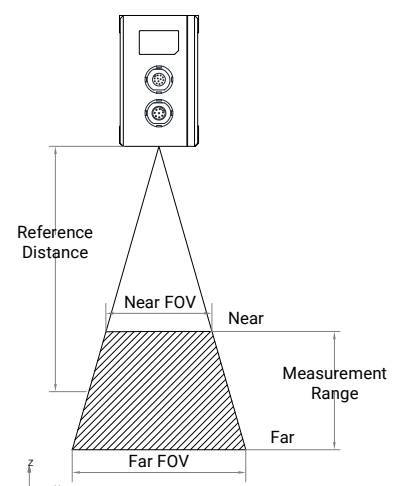

Specification

	Model	MV-DP2120-01P	MV-DP2120-01P V2.0
Parameter		3D Laser Profile Sensor	
Performance			
Data points/profile		2048	3200
Reference distance		120 mm	
Measurement range (Z-axis)		80 mm	
Measurement range (X-axis)		58 mm @ near field of view 76.5 mm @ reference distance 95 mm @ far field of view	
Resolution (Z-axis)		3.66 μm to 8.36 μm	
Repeatability (Z-axis)*		1.48 μm @ data that sensor tests gauge block on optical platform	
Linearity Z-axis (±% of MR)		0.01	
Profile data interval		28.4 μm to 49.6 μm	18.2 μm to 31.7 μm
Scan frame rate		660 Hz (within max. measurement range), max. 10 kHz (in ROI mode)	1.7 kHz to 23.9 kHz (high frame rate mode)
Data output		Original image, profile data, depth image, brightness image	
Trigger mode		Software trigger, hardware trigger (differential encoder)	
Laser safety class		Class 3R	
Wavelength		405 nm	
Electrical feature			
Data interface		Gigabit Ethernet (1000 Mbit/s), compatible with Fast Ethernet (100 Mbit/s)	
Digital I/O		12-pin M12 interface provides power and I/O, including differential input × 3 (Line 0/3/6), differential output × 1 (Line 1), and RS-232 × 1	12-pin M12 interface provides power and I/O, including opto-isolated input × 2 (Line 0/9), differential input × 2 (Line 3/6), and differential output × 1 (Line 1)
Power supply		24 VDC	
Power consumption		Typ. 13.8 W @ 24 VDC	Typ. 15.2 W @ 24 VDC
Mechanical			
Dimension		144.5 mm × 96 mm × 58 mm (5.7" × 3.8" × 2.3")	
Weight		Approx. 950 g (2.1 lb.)	
Ingress protection		IP67	
Temperature		Working temperature: 0 °C to 45 °C (32 °F to 113 °F) Storage temperature: -30 °C to 80 °C (-22 °F to 176 °F)	
Humidity		20% RH to 85% RH (no condensation)	
General			
Client software		3DMVS, VM3D, or third-party software	
Operating system		32/64-bit Windows 7/10, 64-bit Windows 11 (8 GB memory and above, and i5 CPU recommended)	

*This data is obtained via testing gauge blocks in a laboratory, and it is an average from 4096 tests.