

# MV-CS016-11GM

1.6MP 1/2.9" CMOS GigE Area Scan Camera



**GEN*<i>i>*CAM**

**GIG*E***  
VISION

## Introduction

MV-CS016-11GM camera adopts Sony® IMX 273 CMOS sensor to provide high-quality image. It uses GigE interface to transmit non-compressed images in real time, and its max. frame rate can reach 78.2 fps in full resolution.

## Key Feature

- Adopts brand new design to reduce power consumption.
- Supports auto or manual adjustment for gain, exposure time, LUT, Gamma correction, white balance, etc.
- Adopts GigE interface and max. transmission distance of 100 meters without delay.
- Compact design with mounting holes on panels for flexible mounting from 4 sides.
- Compatible with GigE Vision V2.0 Protocol, GenICam Standard, and third-party software based on the protocol and standard.

## Dimension

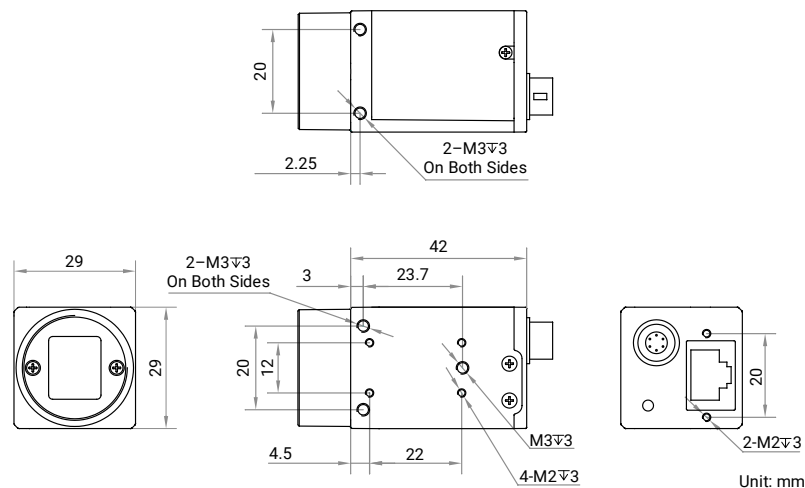

## Available Model

MV-CS016-11GM

## Applicable Industry

Electrical semiconductor, factory automation, food and beverage, pharmaceutical packaging, etc.

## Sensor Quantum

## Efficiency

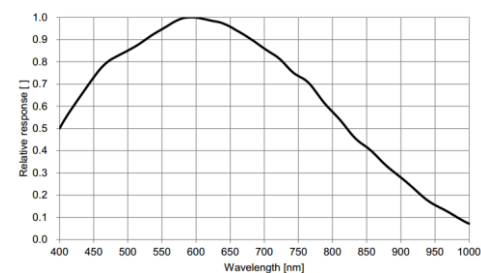

MV-CS016-11GM

## Specification

<b>Model</b>	<b>MV-CS016-11GM</b>
<b>Performance</b>	
<b>Sensor type</b>	CMOS, global shutter
<b>Sensor model</b>	Sony® IMX273
<b>Pixel size</b>	3.45 μm × 3.45 μm
<b>Sensor size</b>	1/2.9"
<b>Resolution</b>	1440 × 1080
<b>Max. frame rate</b>	78.2 fp1440 × 1080 Mono 8
<b>Dynamic range</b>	74 dB
<b>SNR</b>	41 dB
<b>Gain</b>	0 dB to 24 dB
<b>Exposure time</b>	UltraShort exposure mode: 1 μs to 14 μs Standard exposure mode: 15 μs to 10 sec
<b>Exposure mode</b>	Off/Once/Continuous exposure mode
<b>Mono/color</b>	Mono
<b>Pixel format</b>	Mono 8/10/10Packed/12/12Packed
<b>Binning</b>	Supports 1 × 1, 2 × 2
<b>Decimation</b>	Supports 1 × 1, 2 × 2
<b>Reverse image</b>	Supports horizontal and vertical reverse image output
<b>Electrical feature</b>	
<b>Data interface</b>	Gigabit Ethernet (1000 Mbit/s), compatible with Fast Ethernet (100 Mbit/s)
<b>Digital I/O</b>	6-pin P7 connector provides power and I/O, including opto-isolated input × 1 (Line 0), opto-isolated output × 1 (Line 1), bi-directional non-isolated I/O × 1 (Line 2).
<b>Power supply</b>	9 VDC to 24 VDC, supports PoE
<b>Power consumption</b>	Typ. 2.3 W @ 12 VDC
<b>Mechanical</b>	
<b>Lens mount</b>	C-mount
<b>Dimension</b>	29 mm × 29 mm × 42 mm (1.1" × 1.1" × 1.2")
<b>Weight</b>	Approx. 100 g (0.22 lb.)
<b>Ingress protection</b>	IP40 (under proper lens installation and wiring)
<b>Temperature</b>	Working temperature: -30 °C to 60 °C (-22 °F to 140 °F) Storage temperature: -30 °C to 80 °C (-22 °F to 176 °F)
<b>Humidity</b>	20% RH to 95% RH (no condensation)
<b>General</b>	
<b>Client software</b>	MVS or third-party software meeting with GigE Vision Protocol
<b>Operating system</b>	32/64-bit Windows 7/10, 64-bit Windows 11, 32/64-bit Linux
<b>Compatibility</b>	GigE Vision V2.0, GenICam
<b>Certification</b>	CE, RoHS, KC