

Hikrobot Co., Ltd.

CoaXPress Line Scan Camera

User Manual

HIKROBOT

Legal Information

© Hangzhou Hikrobot Co., Ltd. All rights reserved.

About this Document

This Document includes instructions for using and managing the Product. Pictures, charts, images and all other information hereinafter are for description and explanation only. The information contained in the Document is subject to change, without notice, due to firmware updates or other reasons. Please find the latest version in the company website (<https://en.hikrobotics.com/>). Unless otherwise agreed, Hangzhou Hikrobot Co., Ltd. or its affiliates (hereinafter referred to as "Hikrobot") makes no warranties, express or implied. Please use the Document with the guidance and assistance of professionals trained in supporting the Product.

Acknowledgment of Intellectual Property Rights

- Hikrobot owns the copyrights and/or patents related to the technology embodied in the Products described in this Document, which may include licenses obtained from third parties. Any part of the Document, including text, pictures, graphics, etc., belongs to Hikrobot. No part of this Document may be excerpted, copied, translated, or modified in whole or in part by any means without written permission.
- **HIKROBOT** and other Hikrobot's trademarks and logos are the properties of Hikrobot in various jurisdictions. Other trademarks and logos mentioned are the properties of their respective owners.

LEGAL DISCLAIMER

TO THE MAXIMUM EXTENT PERMITTED BY APPLICABLE LAW, THIS MANUAL AND THE PRODUCT DESCRIBED, WITH ITS HARDWARE, SOFTWARE AND FIRMWARE, ARE PROVIDED "AS IS" AND "WITH ALL FAULTS AND ERRORS". HIKROBOT MAKES NO WARRANTIES, EXPRESS OR IMPLIED, INCLUDING WITHOUT LIMITATION, MERCHANTABILITY, SATISFACTORY QUALITY, OR FITNESS FOR A PARTICULAR PURPOSE. THE USE OF THE PRODUCT BY YOU IS AT YOUR OWN RISK. IN NO EVENT WILL HIKROBOT BE LIABLE TO YOU FOR ANY SPECIAL, CONSEQUENTIAL, INCIDENTAL, OR INDIRECT DAMAGES, INCLUDING, AMONG OTHERS, DAMAGES FOR LOSS OF BUSINESS PROFITS, BUSINESS INTERRUPTION, OR LOSS OF DATA, CORRUPTION OF SYSTEMS, OR LOSS OF DOCUMENTATION, WHETHER BASED ON BREACH OF CONTRACT, TORT (INCLUDING NEGLIGENCE), PRODUCT LIABILITY, OR OTHERWISE, IN CONNECTION WITH THE USE OF THE PRODUCT, EVEN IF HIKROBOT HAS BEEN ADVISED OF THE POSSIBILITY OF SUCH DAMAGES OR LOSS.

YOU ACKNOWLEDGE THAT THE NATURE OF INTERNET PROVIDES FOR INHERENT SECURITY RISKS, AND HIKROBOT SHALL NOT TAKE ANY RESPONSIBILITIES FOR ABNORMAL OPERATION, PRIVACY LEAKAGE OR OTHER DAMAGES RESULTING FROM CYBER-ATTACK, HACKER ATTACK, VIRUS INFECTION, OR OTHER INTERNET SECURITY RISKS; HOWEVER, HIKROBOT WILL PROVIDE TIMELY TECHNICAL SUPPORT IF REQUIRED.

YOU AGREE TO USE THIS PRODUCT IN COMPLIANCE WITH ALL APPLICABLE LAWS, AND

YOU ARE SOLELY RESPONSIBLE FOR ENSURING THAT YOUR USE CONFORMS TO THE APPLICABLE LAW. ESPECIALLY, YOU ARE RESPONSIBLE, FOR USING THIS PRODUCT IN A MANNER THAT DOES NOT INFRINGE ON THE RIGHTS OF THIRD PARTIES, INCLUDING WITHOUT LIMITATION, RIGHTS OF PUBLICITY, INTELLECTUAL PROPERTY RIGHTS, OR DATA PROTECTION AND OTHER PRIVACY RIGHTS. YOU SHALL NOT USE THIS PRODUCT FOR ANY PROHIBITED END-USES, INCLUDING THE DEVELOPMENT OR PRODUCTION OF WEAPONS OF MASS DESTRUCTION, THE DEVELOPMENT OR PRODUCTION OF CHEMICAL OR BIOLOGICAL WEAPONS, ANY ACTIVITIES IN THE CONTEXT RELATED TO ANY NUCLEAR EXPLOSIVE OR UNSAFE NUCLEAR FUEL-CYCLE, OR IN SUPPORT OF HUMAN RIGHTS ABUSES.

THE PERFORMANCE DATA IN THIS PUBLICATION IS BASED ON HIKROBOT'S INTERNAL RESEARCH/EVALUATION. ACTUAL DATA MAY VARY DEPENDING ON SPECIFIC CONFIGURATIONS AND OPERATING CONDITIONS AND HIKROBOT SHALL NOT BEAR THE CONSEQUENCES ARISING THEREFROM.

IN THE EVENT OF ANY CONFLICTS BETWEEN THIS MANUAL AND THE APPLICABLE LAW, THE LATTER PREVAILS.

Regulatory Information

Note

These clauses apply only to the products bearing the corresponding mark or information.

EU Conformity Statement



This product and - if applicable - the supplied accessories too are marked with "CE" and comply therefore with the applicable harmonized European standards listed under the Directive 2014/30/EU(EMCD), Directive 2001/95/EC(GPSD) and Directive 2011/65/EU(RoHS).



2012/19/EU (WEEE directive): Products marked with this symbol cannot be disposed of as unsorted municipal waste in the European Union. For proper recycling, return this product to your local supplier upon the purchase of equivalent new equipment, or dispose of it at designated collection points. For more information see: <http://www.recyclethis.info>



Regulation (EU) 2023/1542(Battery Regulation): This product contains a battery and it is in conformity with the Regulation (EU) 2023/1542. The battery cannot be disposed of as unsorted municipal waste in the European Union. See the product documentation for specific battery information. The battery is marked with this symbol, which may include lettering to indicate cadmium (Cd), or lead (Pb). For proper recycling, return the battery to your supplier or to a designated collection point. For more information see: www.recyclethis.info.

Warning: This is a class A product. In a domestic environment this product may cause radio interference in which case the user may be required to take adequate measures.



KC Mark Certification

Class A: The device is advised to note that as a seller or a business user (Class A) Devices and intended for use outside the Home area.

A급 기기: 이 기기는 업무용(A급) 전자파적합기기로서 판매자 또는 사용자는 이 점을 주의하시기바라며, 가정 외의 지역에서 사용하는 것을 목적으로 합니다.

Symbol Conventions

The symbols that may be found in this document are defined as follows.

Symbol	Description
 Danger	Indicates a hazard with a high level of risk, which if not avoided, will result in death or serious injury.
 Caution	Indicates a potentially hazardous situation which, if not avoided, could result in equipment damage, data loss, performance degradation, or unexpected results.
 Note	Provides additional information to emphasize or supplement important points of the main text.

Available Model

This manual is applicable to the CoaXPress Line Scan Camera.

Contact Information

Hangzhou Hikrobot Co., Ltd.

E-mail: global.support@hikrobotics.com

Website: <https://en.hikrobotics.com/>

Contents

Chapter 1 Safety Instruction	1
1.1 Safety Claim.....	1
1.2 Safety Instruction.....	1
1.3 Electromagnetic Interference Prevention	3
Chapter 2 Cleaning Instruction	4
2.1 Device and Lens Cleaning	4
2.1.1 Rubber Dust Air Blower	4
2.1.2 Mirror Brush Cleaning.....	5
2.1.3 Lens Wiping.....	5
2.1.4 Lens Cleaning Paper	6
2.2 Device Housing Cleaning	7
Chapter 3 Overview	8
3.1 Introduction.....	8
3.2 Key Features	8
3.3 Operating Principle.....	8
Chapter 4 Device Hardware	10
4.1 Appearance	10
4.2 Power and I/O Connector.....	11
4.3 Indicator.....	12
4.3.1 Device Indicator.....	13
4.3.2 CoaXPress Linking Indicator.....	13
Chapter 5 Power Supply and Heat Dissipation	15
5.1 Device Power Supply	15
5.1.1 PoCXP Power Supply.....	15
5.1.2 DC Power Supply	15
5.2 Heat Dissipation.....	16
5.2.1 Temperature Parameter	16
5.2.2 Heat Dissipation Measures	18
5.2.3 Low Heat Conduction Material.....	19

Chapter 6 Accessories	21
6.1 Lens	21
6.1.1 Lens Mount	21
6.1.2 Lens Selection	21
6.2 Cable	22
6.2.1 Cable Selection	22
6.2.2 Wiring Principle	22
Chapter 7 Quick Start Guide	25
7.1 Device Installation	25
7.1.1 Installation Preparation	25
7.1.2 Install Device	25
7.2 Install Client Software	27
7.3 Connect Device to Client Software	29
Chapter 8 I/O Electrical Features and Wiring	32
8.1 I/O Electrical Features	32
8.1.1 Differential Input Circuit	32
8.1.2 Differential Output Circuit	33
8.2 Signal Wiring	34
8.2.1 Input Signal Wiring	34
8.2.2 Output Signal Wiring	37
Chapter 9 Trigger Input and Output	39
9.1 Trigger Input	39
9.1.1 Set Trigger Mode	39
9.1.2 Set Trigger Source	40
9.1.3 Set Trigger Related Parameters	50
9.2 Trigger Output	59
9.2.1 Enable Line Inverter	59
9.2.2 Enable Strobe Signal	60
Chapter 10 Image Acquisition	66
10.1 Set Line Rate	66
10.1.1 Line Rate Overview	66
10.1.2 Adjust Line Rate	66

10.2 Set Scan Mode	68
10.3 Set Scan Direction	68
10.4 Set Frame Timeout	69
10.5 Set Line Discard Function	71
Chapter 11 Image Parameter	72
11.1 Set Resolution and ROI	72
11.2 Set Image Reverse	73
11.3 Set Pixel Format	73
11.4 Set Test Pattern	74
11.5 Set Binning	75
11.6 Set Exposure Mode	75
11.7 Set Brightness	76
11.8 Set Black Level	78
11.9 Set Gamma Correction	78
11.10 Set Gain	80
11.10.1 Set Analog Gain	80
11.10.2 Set Digital Gain	81
11.11 Set Sharpness	81
11.12 Set Digital Noise Reduction	81
11.13 Set AOI	82
11.14 Set Sensor Mode	83
11.15 Set Sequence	83
11.16 Set TDI Function	85
11.17 Set Multiple Lights Control	86
11.18 Set LUT	87
11.19 Set Shading Correction	88
11.19.1 Set FPNC Correction	88
11.19.2 Set PRNUC Correction	90
11.20 Set Space Correction	92
11.20.1 Set Line Rate Ratio	93
11.20.2 Set Pixel Shift and Parallax Direction	93

Chapter 12 Other Functions	95
12.1 Device Control	95
12.2 Transport Layer Control	96
12.3 CoaXPress Interface Parameters	96
12.4 Event Control	98
12.5 File Access Control	99
12.6 Update Firmware	100
12.7 User Set Customization	102
12.7.1 Save User Set	102
12.7.2 Load User Set	103
12.7.3 Set User Default	103
Chapter 13 FAQ (Frequently Asked Question)	104
13.1 Why the client software cannot list devices?.....	104
13.2 Why the live view is black?	104
13.3 Why the device cannot be triggered although the live view is normal?.....	104
13.4 Why images required by algorithm cannot get although the live view and trigger signal are normal?	105
Chapter 14 Revision History	106
Appendix A Device Parameter Index	107
A.1 Device Control	107
A.2 Image Format Control.....	108
A.3 Acquisition and Transfer Control	109
A.4 Advanced Processing	110
A.5 Shading Correction.....	111
A.6 I/O Control	112
A.7 Event Control	114
A.8 User Set Control	114

Chapter 1 Safety Instruction

The safety instructions are intended to ensure that the user can use the device correctly to avoid danger or property loss. Read and follow these safety instructions before installing, operating and maintaining the device.

1.1 Safety Claim

- To ensure personal and device safety, when installing, operating, and maintaining the device, follow the signs on the device and all safety instructions described in the manual.
- The note, caution and danger items in the manual do not represent all the safety instructions that should be observed, but only serve as a supplement to all the safety instructions.
- The device should be used in an environment that meets the design specifications, otherwise it may cause malfunctions, and malfunctions or component damage caused by non-compliance with relevant regulations are not within the scope of the device's quality assurance.
- Our company will not bear any legal responsibility for personal safety accidents and property losses caused by abnormal operation of the device.

1.2 Safety Instruction

Caution:

- Do not install the device if it is found that the device and accessories are damaged, rusted, water ingress, model mismatch, missing parts, etc., when unpacking.
- Avoid storage and transportation in places such as water splashing and rain, direct sunlight, strong electric fields, strong magnetic fields, and strong vibrations.
- Avoid dropping, smashing or vigorously vibrating the device and its components.
- It is forbidden to install the indoor device in an environment where it may be exposed to water or other liquids. If the device is damp, it may cause fire and electric shock hazard.
- Place the device in a place out of direct sunlight and ventilation, away from heat sources such as heaters and radiators.
- In the use of the device, you must be in strict compliance with the electrical safety regulations of the nation and region.
- Use the power adapter provided by the official manufacturer. The power adapter must meet the Limited Power Source (LPS) requirements. For specific requirements, please refer to the device's technical specifications.
- Do not cover the device's plug or outlet for disconnecting power supply.
- It is strictly forbidden to wire, maintain, and disassemble the device is powered on.

Otherwise, there is a danger of electric shock.

- If the device emits smoke, odor or noise, please turn off the power and unplug the power cord immediately, and contact the dealer or service center in time.
- It is strictly forbidden to touch any terminal of the device when operating it. Otherwise there is a danger of electric shock.
- It is strictly forbidden for non-professional technicians to detect signals during device operation, otherwise it may cause personal injury or device damage.
- It is strictly forbidden to maintain the device is powered on, otherwise there is a danger of electric shock.
- Avoid aiming the lens at strong light (such as lighting, sunlight, or laser beams, etc.), otherwise the image sensor will be damaged.
- Keep clean of the device's image acquisition window. It is recommended to use cleaning water (not the alcohol-based corrosive solutions) to wipe off the dust. When the device is not in use, please add a dust cover to protect the image acquisition window.
- If the device does not work properly, please contact your dealer or the nearest service center. Never attempt to disassemble the device yourself (we shall not assume any responsibility for problems caused by unauthorized repair or maintenance).
- Please dispose of the device in strict accordance with the relevant national or regional regulations and standards to avoid environmental pollution and property damage.

Note:

- Check whether the device's package is in good condition, whether there is damage, intrusion, moisture, deformation, etc. before unpacking.
- Check the surface of the device and accessories for damage, rust, bumps, etc. when unpacking.
- Check whether the quantity and information of the device and accessories are complete after unpacking.
- Store and transport the device according to the storage and transport conditions of the device, and the storage temperature and humidity should meet the requirements.
- It is strictly prohibited to transport the device in combination with items that may affect or damage the device.
- Quality requirements for installation and maintenance personnel:
 - Qualification certificate or working experience in weak current system installation and maintenance, and relevant working experience and qualifications. Besides, the personnel must possess the following knowledge and operation skills.
 - The basic knowledge and operation skills of low voltage wiring and low voltage electronic circuit connection.
 - The ability to comprehend the contents of this manual.
- Please read the manual and safety instructions carefully before installing the device.
- Please install the device strictly according to the installation method in this manual.
- The case of the device may be overheated, and it needs to be powered off for half an hour before it can be touched.
- The device should not be placed with exposed flame sources, such as lighted candles.

1.3 Electromagnetic Interference Prevention

- Make sure that the shielding layer of cables is intact and 360° connected to the metal connector when using shielded cables.
- Do not route the device together with other equipment (especially servo motors, high-power devices, etc.), and control the distance between cables to more than 10 cm. Make sure to shield the cables if unavoidable.
- The control cable of the device and the power cable of the industrial light source must be wired separately to avoid bundled wiring.
- The power cable, data cable, signal cable, etc. of the device must be wired separately. Make sure to ground them if the wiring groove is used to separate the wiring and the wiring groove is metal.
- During the wiring process, evaluate the wiring space reasonably, and do not pull the cables hard, so as not to damage the electrical performance of the cables.
- If the device is powered on and off frequently, it is necessary to strengthen the voltage isolation, and consider adding a DC/DC isolation power supply module between the device and the adapter.
- Use the power adapter to supply power to the device separately. If centralized power supply is necessary, make sure to use a DC filter to filter the power supply of the device separately before use.
- The unused cables of the device must be insulated.
- When installing the device, if you cannot ensure that the device itself and all equipment connected to the device are well grounded, you should isolate the device with an insulating bracket.
- To avoid the accumulation of static electricity, ensure that other equipment (such as machines, internal components, etc.) and metal brackets on site are properly grounded.
- During the installation and use of the device, high voltage leakage must be avoided.
- Use a figure-eight bundle method if the device cable is too long.
- When connecting the device and metal accessories, they must be connected firmly to maintain good conductivity.
- Use a shielded network cable to connect to the device. If you use a self-made network cable, make sure that the shielding shell at the aviation head is well connected to the aluminum foil or metal braid of the shielding cable.

Chapter 2 Cleaning Instruction

2.1 Device and Lens Cleaning

Four ways are available to clean the device and lens when they have dust or stains. Refer to the following table for different devices and their supported cleaning methods.

Table 2-1 Device and Cleaning Method

Cleaning Method	Device	
	Camera	Lens
Rubber Dust Air Blower	Support	Support
Mirror Brush Cleaning	Not Support	Support
Lens Wiping	Support	Support
Lens Cleaning Paper	Not Support	Support

2.1.1 Rubber Dust Air Blower

You can use a rubber dust air blower to clean the dust on the surface of the device filter and lens. The specific operation steps are as follows:

Steps

1. Blow the rubber dust air blower downward several times to blow out the dust inside.
2. Hold the device or lens and tilt it down so that the air blower port and the device lens are at an angle of 45 degrees.
3. Blow to clean the dust on the surface of the device filter and lens.



Figure 2-1 Cleaning by Rubber Dust Air Blower

Note

- Do not go too far into the device's lens mount and avoid direct contact with the dust glass when cleaning.
 - It is strictly forbidden to blow the lens directly from the mouth, and avoid spattering saliva particles onto the glass surface, causing serious secondary pollution.
-

2.1.2 Mirror Brush Cleaning

If the dust on the surface of the lens cannot be cleaned by rubber dusk air blower, use a mirror brush to gently remove the dust on the surface of the lens.

Note

Do not touch the bristles directly with your hands.

2.1.3 Lens Wiping

For the stubborn stains on device filter or lens surface, such as finger marks, liquid stains, etc., it is recommended to use a fat-free cotton swab or dust-free cloth with high purity alcohol to wipe clean. Take the fat-free cotton swab as an example, and the specific operation steps are as follows:

Steps

1. Take a clean fat-free cotton swab, and dip it in proper amount of alcohol or cleaning liquid.
-

Note

Do not touch the head of the cotton swab by fingers.

2. Tilt the fat-free cotton swab about 60 degrees, resist the device filter or lens surface, clean from left to right, turn cotton swab over one side, and clean again from right to left.
3. Take another fat-free cotton swab that is not stained with alcohol or cleaning liquid and swipe the device filter or lens to absorb the remaining alcohol or cleaning liquid.
4. Check whether there is still a stain. If the stain changes position, repeat steps above, until the stain is cleaned.



Figure 2-2 Lens Wiping

Note

If the stains on the lens cannot be wiped or clean, please clean by using lens cleaning paper. For specific operation steps, please refer to the next section.

2.1.4 Lens Cleaning Paper

For lens stains that cannot be cleaned by a fat-free cotton swab or dust-free cloth, use lens cleaning paper to clean them.

Before You Start

- Use lens paper purchased from a regular, professional photography store.
- Use freshly opened lens cleaning paper in a wet state.
- Make sure there is no hard dust on the lens.

Tear off the outer package of the lens cleaning paper, fold the pre-moistened paper to a suitable wiping state, and slowly spiral wipe it in the same direction from the center of the lens outward.

Note

- Do not use hard paper, paper towels, or napkins to clean the lens. These products contain scratching wood pulp, which will seriously damage delicate coating on the lens.
 - Do not press the lens surface hard when cleaning it the lens cleaning paper. Otherwise, the fragile coating on the lens surface will be wiped off.
-

After completing the lens cleaning, no dust or water stains should be visible from all directions on the lens. If stains still exist, please contact us to return the device for cleaning.

2.2 Device Housing Cleaning

When cleaning the device, try to clean it in a closed room to avoid a large amount of dust in the environment. The specific operation steps are as follows:

Steps

1. Disconnect the device's power supply.
2. Take a soft lint-free cloth that will not cause static electricity during cleaning and soak it with a neutral detergent.
3. Wipe the device's housing with a soaked, lint-free cloth as appropriate.
4. Wait for the residual moisture to evaporate after wiping. When the moisture has completely evaporated, you can reconnect the device to the power supply.

Note

Do not use compressed air to accelerate evaporation.

After inspecting and confirming that the device lens and its housing are cleaned, install the device lens cap with the mount facing downwards, or store the lens properly.

Chapter 3 Overview

3.1 Introduction

The CoaXPress (CXP) line scan camera transmits non-compressed images via CoaXPress interface in real time, and it acquires images and sets parameters via client software or SDK based on CoaXPress frame grabber. It is applicable to new energy, screen detection, consumer electronics, PCB, semiconductor, etc.

3.2 Key Features

- Provides high dynamic range, signal noise ratio (SNR), and high-quality image.
- Supports auto and manual adjustment for gain, exposure time, LUT, Gamma correction, etc.
- Adopts CoaXPress interface to transmit data.
- Compatible with CoaXPress Protocol and GenICam Standard.

Note

- The specific functions may differ by device models.
 - Refer to the device's specifications for specific parameters.
-

3.3 Operating Principle

The onboard block diagram of the device is shown below. After the image sensor receives the image data, it completes the image data processing through various built-in ISP image-processing algorithms, and finally completes the high-speed transmission of image data through the CoaXPress protocol.

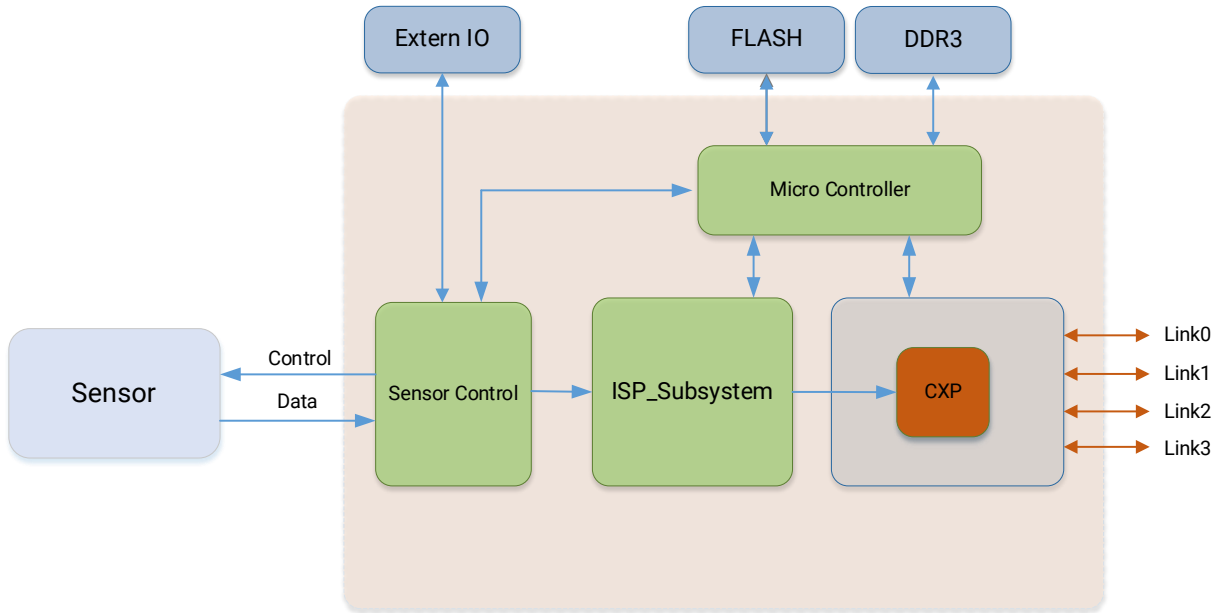

Figure 3-1 Operating Principle

Chapter 4 Device Hardware

4.1 Appearance

Refer to the figure below for device appearance and the table below for component description.

Note

- The device's appearance may differ by device models. The image below is for reference only. For specific appearance and dimension, please refer to the device's specification for details.
- The appearance is subject to change, and the actual device you purchased shall prevail.

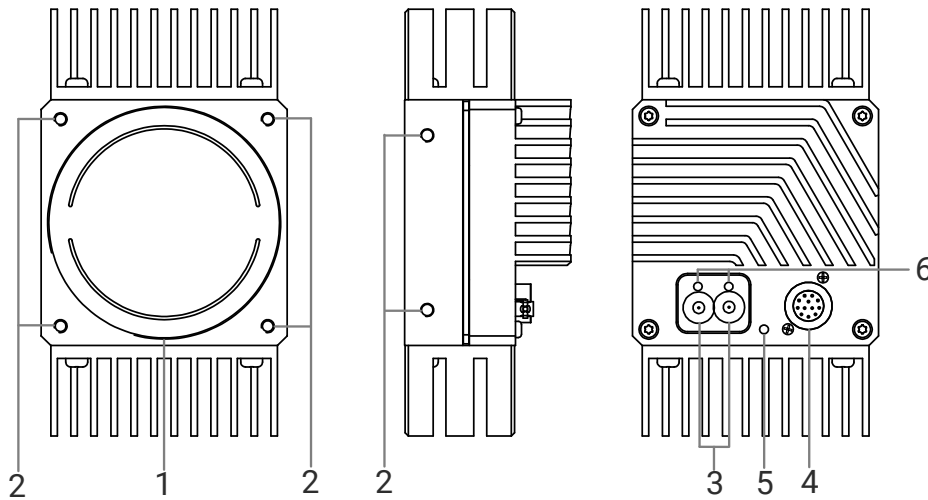

Figure 6-1 Appearance (Type I)

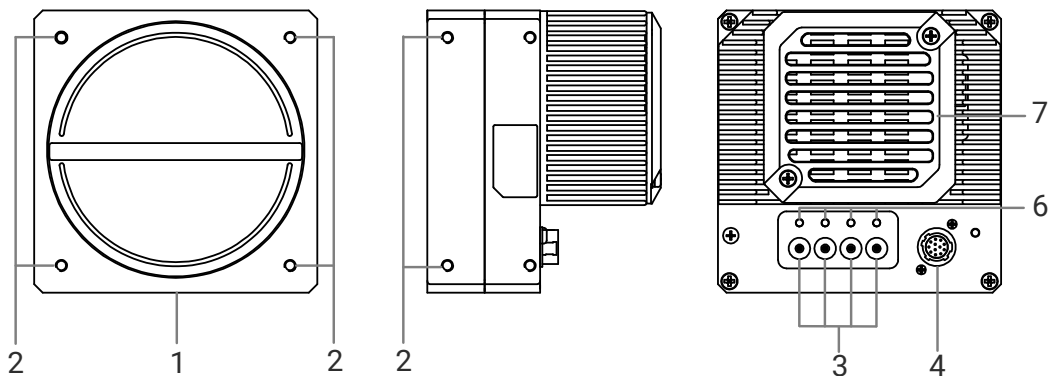

Figure 6-2 Appearance (Type II)

Table 4-1 Component Description

No.	Component	Description
1	Lens Mount	It is used to install lens. Refer to the device's specification for details.
2	Screw Hole	It is used to fix the device to the installation position. Refer to the device's specification for details.
3	CoaXPress Interface	It is a Micro-BNC interface and used for transmitting data. The device has 2 to 4 CoaXPress interfaces on the back of the device. You can use 1/2/3/4 CoaXPress cable(s). The data bandwidth varies with the number of interfaces. Refer to the device's specification for details.
4	Power and I/O Connector	It provides power supply, I/O, and serial port function. It refers to a 12-pin P10 connector. Refer to the device's specification and section Power and I/O Connector for details.
5	Device Indicator	It indicates the device's status. See section Device Indicator for details.
6	CoaXPress Linking Indicator	It indicates CoaXPress linking connection status via CoaXPress cable. It has 2 to 4 LEDs. See section CoaXPress Linking Indicator for details.
7	Fan	It is used to cool the device to ensure its normal operation.

4.2 Power and I/O Connector

The device has a 12-pin P10 connector serving as the power and I/O connector that provides power supply, I/O, and serial port function, as shown below.

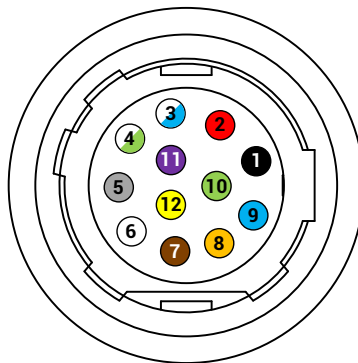

Figure 6-3 12-Pin P10 Connector

Table 4-2 Pin Definitions

No.	Color	Signal	I/O Signal Source	Description
1	Black	GND	--	Power supply ground
2	Red	DC_PWR	--	DC power supply+
3	White/Blue	LINE0_P	Line 0+	Differential input/output I/O 0+
4	White/Green	LINE0_N	Line 0-	Differential input/output I/O 0-
5	Gray	GND	--	Power supply ground
6	White	LINE3_P	Line 3+	Differential input/output I/O 3+
7	Brown	LINE3_N	Line 3-	Differential input/output I/O 3-
8	Orange	LINE4_P	Line 4+	Differential input/output I/O 4+
9	Blue	LINE1_P	Line 1+	Differential input/output I/O 1+
10	Green	LINE1_N	Line 1-	Differential input/output I/O 1-
11	Purple	DC_PWR	--	DC power supply+
12	Yellow	LINE4_N	Line 4-	Differential input/output I/O 4-

 **Note**

- Refer to the table below and the label attached to the power and I/O cable to wire the device.
- The wire cores shown in figure and table are only the wire sequence and the corresponding wire core color of the cables sold by our company. If the cables are not purchased from our company, please refer to the actual wire sequence and the corresponding wire core color.

4.3 Indicator

The device has two kinds of LED indicators, including device indicator and CoaXPress linking indicator.

 **Note**

- When the indicator is flashing very rapidly, flashing rapidly, or flashing slowly, its unlit interval is 0.08 sec, 0.2 sec, and 1 sec respectively.
- The indicator sometimes may show a purple color when red and blue colors flashing at the same time.

4.3.1 Device Indicator

The device indicator indicates the device's operation status. Refer to the table below for device indicator description.

Table 4-3 Device Indicator Description

No.	Indicator Color	Status	Device Status Description
1	Red	Solid	The device exception occurs.
2	Blue	Solid	There is no data transmission, or data transmission exception occurs after device starts up.
3	Blue	Unlit	The device is powered off.
4	Blue	Flashing rapidly	The device is acquiring images in continuous mode.
5	Blue	Flashing slowly	The device is acquiring images in trigger mode.
6	Red and blue	Flashing alternatively	The device is updating firmware.

4.3.2 CoaXPress Linking Indicator

The CoaXPress linking indicator indicates the CoaXPress linking connection status via the CoaXPress cable. Refer to the table below for the description of the CoaXPress linking indicator.

Table 4-4 CoaXPress Linking Indicator Description

No.	Indicator Color	Status	Device Status Description
1	Unlit		The device is not powered on, CoaXPress wiring is incorrect, or linking is not locked.
2	Orange	Solid	The device is being powered on.
3	Red	Flashing slowly	The device is powered on, CoaXPress wiring is incorrect, and linking is locked, but the client software cannot list the device.
4	Green	Solid	The device is connected to the PC, but no data is being transferred.
5	Green	Flashing very rapidly	The device is acquiring images in continuous mode.
6	Orange	Flashing very rapidly	The device is connected to the PC, and data is being transferred.

CoaXPress Line Scan Camera User Manual

No.	Indicator Color	Status	Device Status Description
7	Orange	Flashing slowly	The device is acquiring images in trigger mode.

Chapter 5 Power Supply and Heat Dissipation

5.1 Device Power Supply

The device provides two ways of power supply: PoCXP power supply and external DC power supply.

When the external DC power supply and PoCXP power supply are executed at the same time, the DC power supply takes priority. If the DC power supply is disconnected, the device will switch to PoCXP power supply and may restart.

5.1.1 PoCXP Power Supply

The device will be powered via Power over CoaXPress (PoCXP). The number of power supply channels depends on the device model. Please refer to the actual one you got.

5.1.2 DC Power Supply

Connect the external DC power supply to the I/O connector through the I/O cable to power the device. Refer to the device's label for the specific voltage range of power supply.

Note

- Using a DC power supply that exceeds the specified voltage range may cause damage or abnormal operation of the device.
 - Inserting a connector that does not match the I/O connector may cause damage or abnormal operation of the device. Refer to section [Power and I/O Connector](#) for details.
 - Do not short-circuit the power supply and ground.
-

You can use an industrial power supply to provide DC power supply for the device. When using it, please observe the following precautions:

- Before carrying out any installation or maintenance work, make sure that the power supply is disconnected from the AC power and that there is no risk of accidental reconnection due to human negligence or wiring issues.
- Do not install the power supply in a humid environment, near liquid, in high-temperature conditions, in direct sunlight, or near flame sources.
- The industrial power supply has exposed high-voltage terminals. Please install it in an enclosed case or cabinet to prevent accidental contact by personnel.
- Maintain sufficient insulation distance between the internal components of the power supply and the screws.
- Ensure that the cooling fan and holes for heat dissipation are unobstructed. If adjacent equipment generates heat, keep it at least 10 cm to 15 cm away from the power supply.
- Make sure the power supply is properly grounded before use.

- When using the power supply, do not exceed the upper limit of its output current and output power. Refer to the power supply's nameplate for specific parameters.
- Non-standard installations or using the power supply in high-temperature environments will increase the temperature of the internal components, potentially reducing output power.
- The power supply contains high-voltage circuits that pose a risk. If any abnormalities occur, disconnect the power first and have it inspected by a technician with professional electrical qualifications. Do not attempt to open the casing yourself.
- Avoid touching the power supply terminals within 5 minutes after the power has been cut off to prevent the risk of electric shock.

5.2 Heat Dissipation

The device contains photosensitive components. If the device's temperature rises, it will have a certain impact on the quality of the acquired image. Based on the above situation, this section will introduce the temperature parameters and installation suggestions to achieve better heat dissipation effect and improve the image quality and reliability of the device.

5.2.1 Temperature Parameter

Working Temperature

The temperature of the key components of industrial cameras is a key factor affecting image quality, operation stability and long-term reliability. The upper limit of the working environment temperature in the specification of the industrial camera refers to the maximum ambient temperature that the device can meet without any additional heat dissipation measures. Running within the working temperature can meet the temperature requirements on the electronic components and ensure the reliable operation of the device.

The monitoring point of the working environment temperature of the device is 80 mm away from the main housing of the device, as shown below. In the space where the device and the temperature measuring point are located, there is no object in the middle and the temperature is evenly distributed.

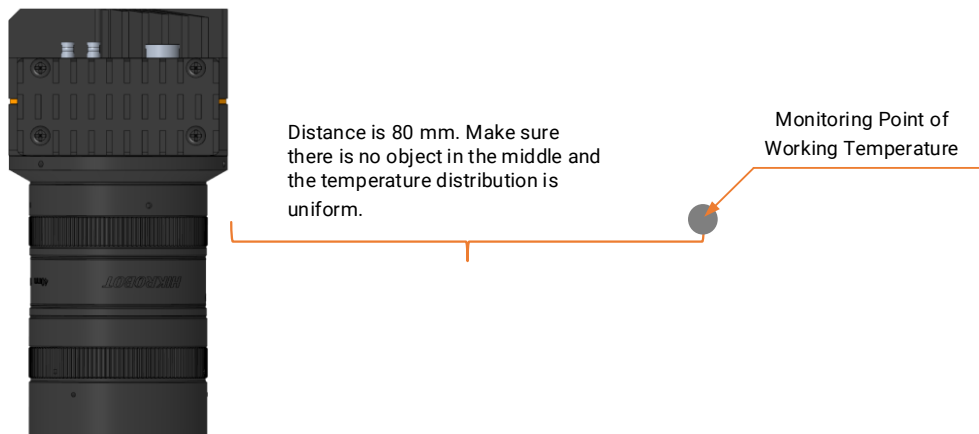

Figure 5-1 Monitoring Point of Working Temperature

Housing Temperature

After the heat generated by the electronic components is conducted to the device's housing, if the device does not have any additional heat dissipation measures, the heat is dissipated to the external environment in the form of convection and radiation through the device's housing.

The temperature of the device's housing will gradually rise during the heat dissipation process, and when the thermal equilibrium state is finally reached, the temperature tends to be stable. Therefore, we often feel that the device's housing has a certain temperature, or feel hot, which is a normal phenomenon of device heat dissipation.

The temperature of the internal electronic components is a key factor affecting image quality, device operating stability, and long-term reliability. Therefore, better image quality and reliability can be obtained by lowering the temperature of the housing and the internal electronic components.

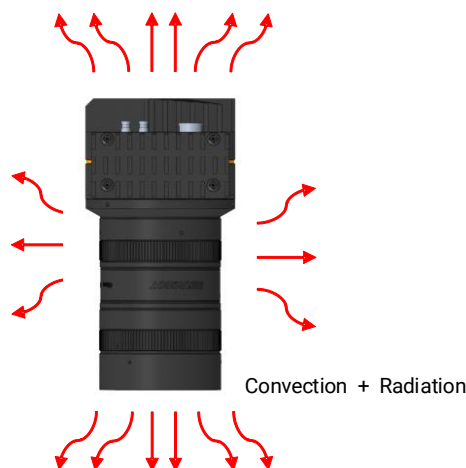

Figure 5-2 Housing Temperature

5.2.2 Heat Dissipation Measures

The temperature of the device housing is influenced by the power consumption, the device size, the environment, and additional heat dissipation measures. By designing the camera to be mounted in the field, additional camera cooling measures can quickly dissipate the heat from the housing to the outside environment.

In the industrial field, the heat of the camera housing can be dissipated through the mounting parts and fixed platforms, and the cooling effect of such cooling measures depends on the thermal conductivity of the material and the mounting parts. This section will be respectively on the material and mounting methods to do specific instructions.

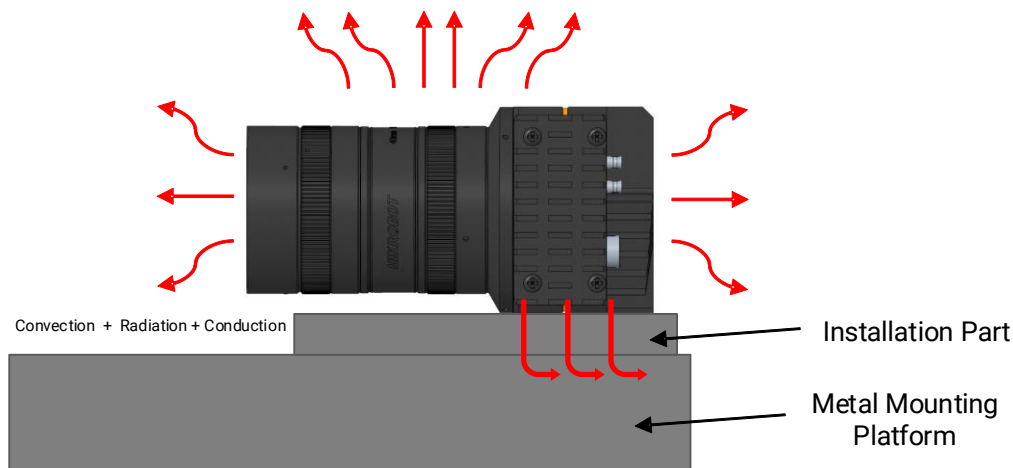

Figure 5-3 Heat Dissipation via Installation Part

- **Installation Part Material**

- Use materials with high heat conduction, such as aluminum and copper, which can quickly transfer heat away.
- Minimize the use of materials with low heat conduction, such as plastic and rubber.

 **Note**

The heat dissipation mentioned in the following part (heat conduction path and contact area) is for materials with high heat conductivity.

- **Heat Conduction Path**

- The heat conduction path of the installation part should be as short as possible to improve the heat conduction efficiency.
- The thickness, length, and bending of the installation part will affect the heat conduction path distance of the device.

As shown in the installation method 1 and 2 in the figure below, the thickness of the installation part should be reduced as much as possible to shorten the heat conduction path from the device to the metal mounting platform via the installation part.

As shown in the installation method 3 and 4 in the figure below, the extension of the length of the installation part and the use of bent metal will lead to the lengthening of the heat conduction path of the device.

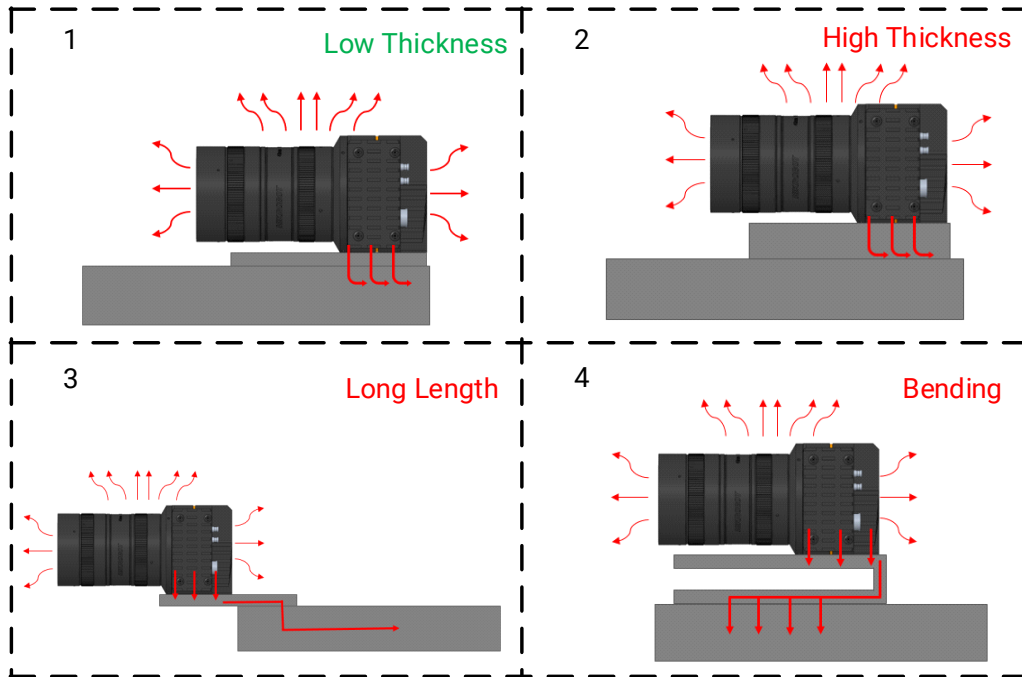

Figure 5-4 Heat Conduction Path of Different Installation Methods

● **Contact Area**

Surface contact should be used among the device, installation parts and the mounting platform, and the contact area between installation surfaces should be increased as much as possible to improve the heat dissipation of the device. The flatness of the installation part should be within 0.1 mm, in case the actual contact surface is not completely close, affecting the heat dissipation effect.

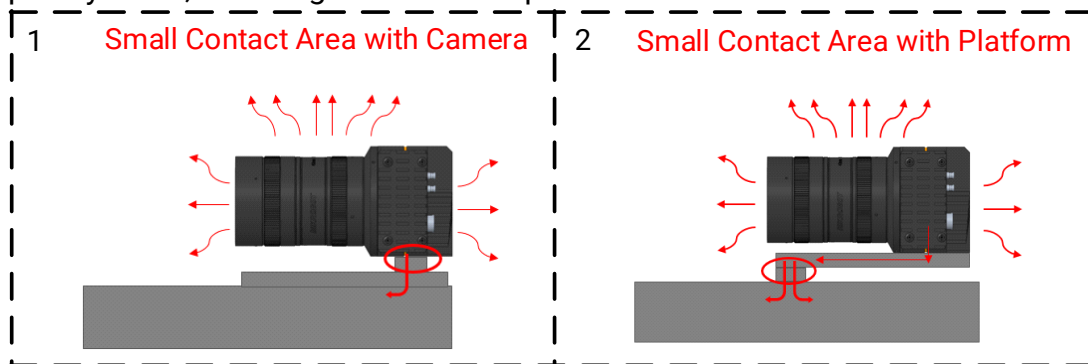

Figure 5-5 Contact Area

5.2.3 Low Heat Conduction Material

If the installation part is made of plastic, rubber, or other materials with poor heat conduction, the application of ventilation equipment such as fans or air conditioners can increase the airflow over the device's surface. This reduces the ambient air temperature around the device, enhancing heat dissipation through convection and thereby reducing the temperature of housing. As a result, the image quality and reliability of the device are

improved.

If the mounting platform is made of materials with very poor heat conduction such as plastic and wall, heat dissipation can be improved in the following ways:

- Increase the surface area of the installation part.
If the installation part is in good contact with the device, it can be regarded as a part of the device's housing. The larger the heat dissipation area of the housing, the better the heat dissipation effect. Therefore, the larger the surface area of the installation part, the better the heat dissipation effect.
- The installation part can be made into a metal heat dissipation tooth shape, or a large area flat plate to improve the heat dissipation effect.

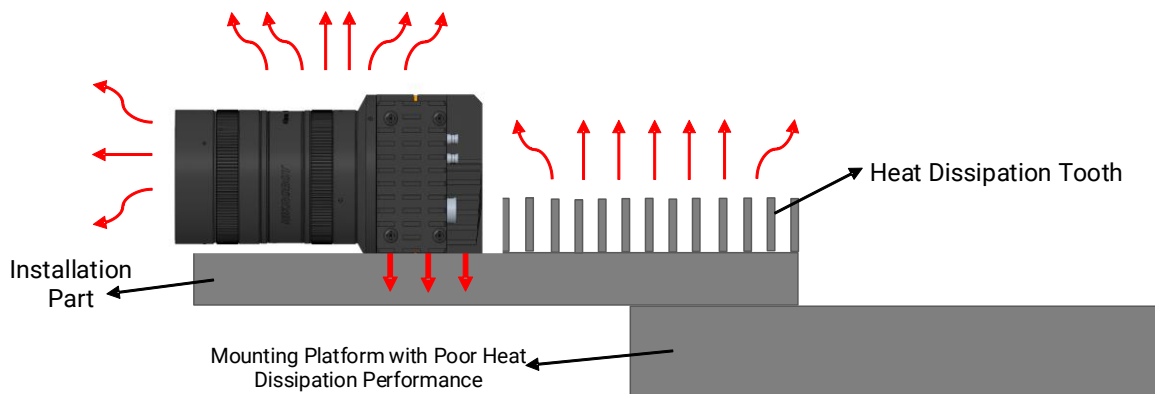

Figure 5-6 Add Heat Dissipation Tooth

- While increasing the heat dissipation area of the installation part, painting and oxidation can be used to increase the radiation heat exchange of the installation part to the external environment and strengthen the heat dissipation of the device.

Chapter 6 Accessories

6.1 Lens

6.1.1 Lens Mount

The device supports standard M72-mount and M90-mount lenses which can be connected to F-mount via the adapter ring. The thread depth of the M72-mount and M90-mount lenses is not less than 5 mm.

6.1.2 Lens Selection

In order to meet the image acquisition needs of industrial cameras, our company provides a variety of lenses with high performance, high definition, low distortion rate, and other features. You should consider following factors when selecting a lens:

- Lens mount: The device supports standard M72-mount and M90-mount lenses. When selecting lens, select lens with the same mount. When the mounts of the device and the lens are different, part of the lens mounts may be connected by using the corresponding adapter ring.
- Flange back length: The flange back length of different lenses is varied. It is necessary to select the lens with the matched flange back length.
- Sensor size: Make sure that the target surface of the lens is larger than or equal to the size of the device's sensor size.
- Resolution: It represents the ability of the lens to record the details of an object. It is generally measured in the number of line pairs that can be distinguished per millimeter: line pairs/millimeter (lp/mm). The higher the resolution of the lens, the clearer the image. Make sure that the accuracy required by the system is less than the resolution of the lens when selecting the lens.
- Working distance: It refers to the distance from the first working surface of the lens to the measured object. Make sure that the working distance is greater than the minimum object distance of the lens when selecting a lens.
- Focal length: The distance from the center point of the lens to the clear image formed on the focal plane. The smaller the focal length value is, the larger the field of view of the image captured by the digital camera is. According to the focal length of the lens, the appropriate working distance can be set up, or the appropriate lens can be selected according to the requirements of the working distance.

Note

In order to better provide a suitable lens model, you can go to the official website of our company (<https://en.hikrobotics.com/>): **Products** → **Lens** → **Lens Selector** to enter

your application parameters, and you will find a suitable lens model. If you have any problems, please contact our technical support.

6.2 Cable

6.2.1 Cable Selection

According to the cable performance, it can be divided into standard, flexible, high flexible and super flexible cables. You need to select cables according to different scenarios.

- Standard cable: It is applicable to static scenario only.
- Flexible cable: It can withstand 100,000 times of drag chain or bending movement.
- High flexible cable: It can withstand 5 million times of drag chain movement.
- Super flexible cable: It can withstand 10 million times of drag chain movement, 3 million times of bending movement or 5 million times of twisting movement.

6.2.2 Wiring Principle

Regarding the power and I/O cable and CoaXPress cable, attention should be paid to the application requirements of scenarios such as high-frequency communication and high-frequency motion. In such scenarios, if the cables are arranged in an inappropriate manner, various problems may be caused in use, such as cable skin wear, internal conductor breakage, and device packet loss. Based on the above situation, this section introduces the basic wiring principles and precautions of sports cables to help you install and use related products correctly and improve the overall healthy operating life of the system.

- The minimum bending radius of the chain rail during wiring should be controlled at more than 10 to 12 times the wire diameter (the larger the bending radius, the longer the cable movement life).
- Make sure that the cable does not spin in the chain rail, and the cable should be spread horizontally along the chain rail.
- If the cable is laid too tightly, the cable sheath and the chain rail will produce friction during the movement, which will cause the sheath to wear. Therefore, in the wiring process, the laying tension on the cable should be avoided.
- If the cable is fixed at the moving part of the chain rail, stress concentration will occur at the fixed position during the movement. Therefore, both ends of the cable can be fixed, but not at the middle moving section.
- Multiple cables may interfere with each other when moving in the chain rail. At this time, the chain rail with sufficient width should be selected to ensure that there is still a certain space after the cables are laid horizontally. The use of spacers is also an effective way to avoid interference. Note that there should also be at least 2 mm clearance between the spacer and the cable. Do not drain cables without spacers.
- Please keep the space factor occupied by the cable after laying within 30%, as shown

below.

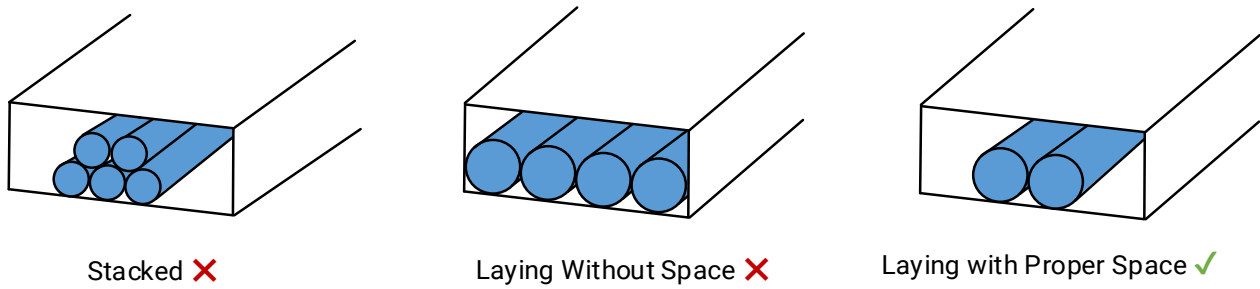

Figure 6-1 Cable Laying

- In the same chain rail, if there are cables with different thicknesses and diameters, the cables with small outer diameter are easily squeezed to the bottom by the cables with large outer diameter. In this case, use spacers for classification and isolation, as shown below.

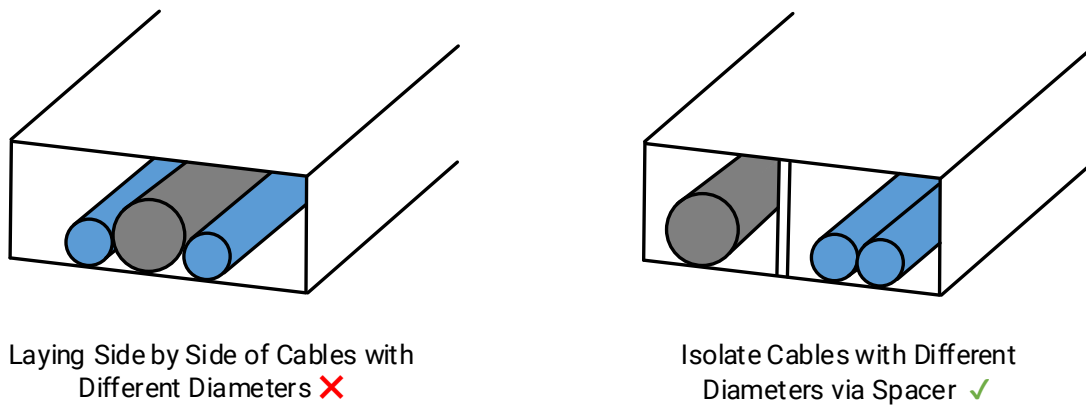

Figure 6-2 Isolated via Spacer

- If the wiring is in the same track as the hard object such as the air pipe, use a spacer to isolate it.
- If the chain rail is damaged, replace the chain rail and cable at the same time, because the damaged chain rail may aggravate the damage to the cable.
- Do not bend the cable vertically on the fixed point.

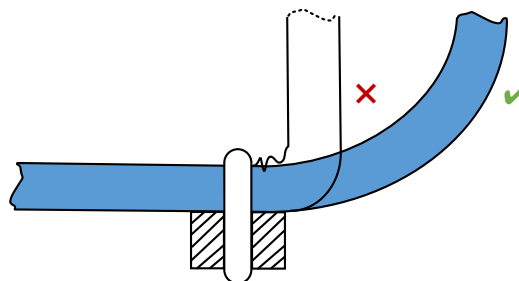

Figure 6-3 Vertically Bended Prohibited

- Make sure to reserve a suitable bending length for the cable.

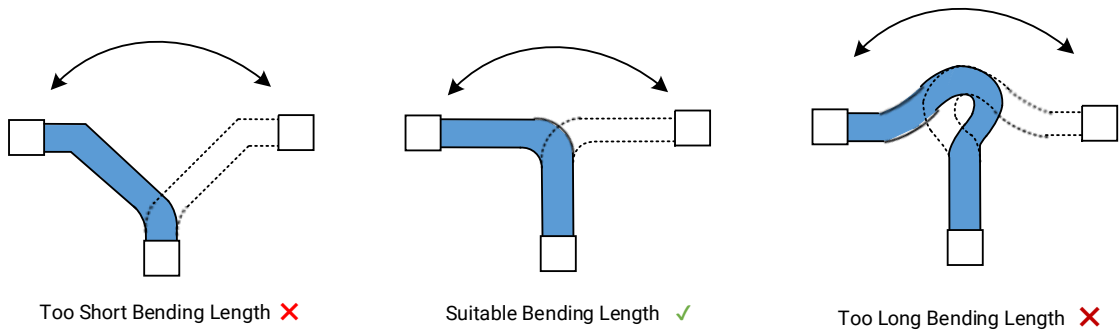

Figure 6-4 Suitable Bending Length

- Please keep a sufficient bending radius.

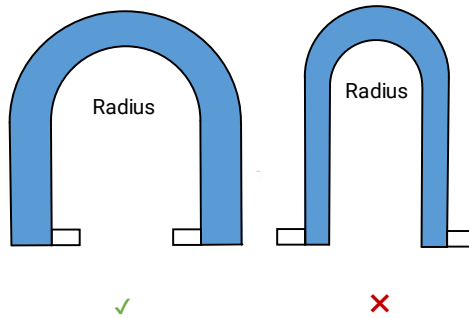

Figure 6-5 Sufficient Bending Radius

- When assembling the connector, please fix it on the connector net tail instead of the cable body.

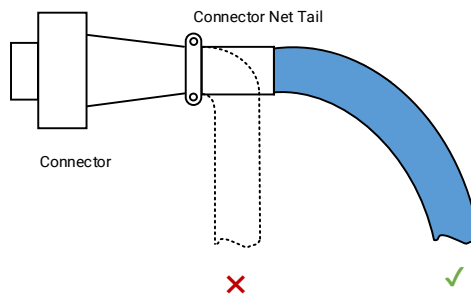

Figure 6-6 Assemble Connector

- Do not bind cables of different diameters together.

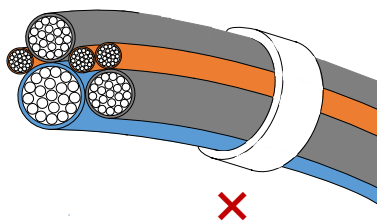

Figure 6-7 Improper Binding

Chapter 7 Quick Start Guide

7.1 Device Installation

7.1.1 Installation Preparation

You need to prepare following accessories before device installation.

Table 7-1 Accessories

No.	Name	Quantity	Description
1	Power and I/O Cable (Required)	1	It refers to the 12-pin power and I/O cable. You need to purchase separately.
2	DC Power Supply (Required)	1	You should select an appropriate power adapter or switch power supply according to the device power supply and consumption. You need to purchase separately.
3	Frame Grabber (Required)	1	It refers to the CoaXPress frame grabber. You need to purchase separately.
4	CoaXPress Cable(s) (Required)	1/2/3/4	It refers to the CXP-12 cable. You can use 1/2/3/4 CoaXPress cable(s) to transmit data. You need to purchase separately in accordance with device's CoaXPress interface type, cable protocol, and frame grabber model.
5	Lens (Required)	1	It refers to the lens that is suitable for the device. You need to purchase separately.
6	Lens Adapter (Optional)	1	If the lens you used does not match with lens mount of the device, you need to use a lens adapter. You need to purchase separately.

7.1.2 Install Device

The topology diagram of the device is shown below.

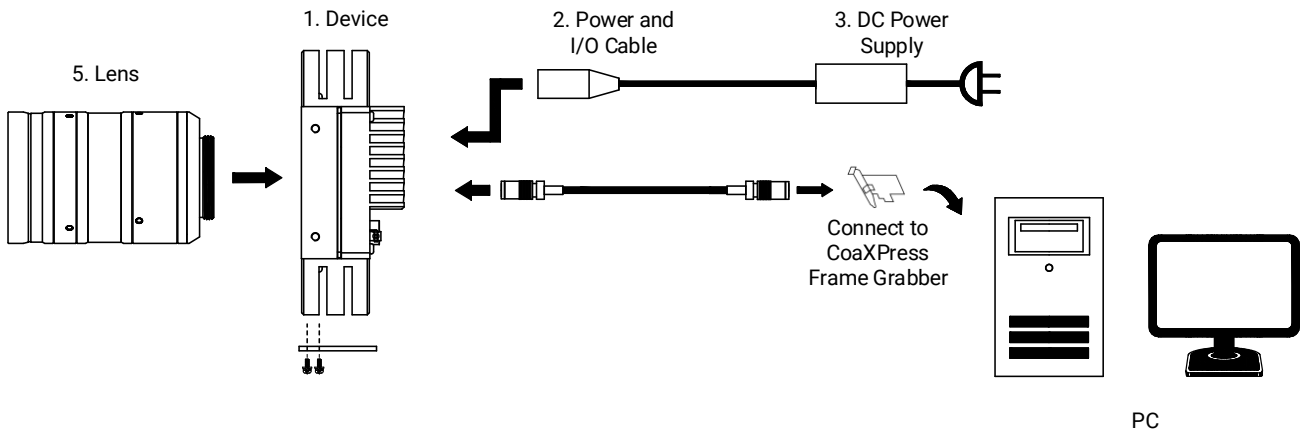

Figure 7-1 Topology Diagram

Note

The topology diagram is for reference only.

Before You Start

- Make sure the device in the package is in good condition and all the assembly parts are included.
- Make sure all the related equipment is powered off during the installation.

Steps

1. Fix the device to the installation position, select an appropriate lens, and install on the device.
-

Note

During device installation, heat dissipation measures of installation parts can be taken to improve the efficiency of heat dissipation. Refer to section [Heat Dissipation Measures](#) for details.

2. Connect the device to the CoaXPress frame grabber via the CoaXPress cable.
-

Note

- You need to select the CoaXPress cable in accordance with device's CoaXPress interface type, cable protocol, and frame grabber model.
 - The device has 1 or 2 CoaXPress interfaces, and it can transmit data via 1 or 2 CoaXPress cable(s). The data bandwidth and device interface vary with the number of interfaces.
-

Table 7-2 Device Interface and Link Configuration

Used Interface Quantity	Device Interface	Link Configuration
1	CXP0	1 Link 3.125 Gbps, 1 Link 6.25 Gbps, 1 Link 12.5 Gbps
2	CXP0, CXP1	1 Link 3.125 Gbps, 1 Link 6.25 Gbps, 1 Link 12.5 Gbps, 2 Link 3.125 Gbps, 2 Link 6.25 Gbps, 2 Link 12.5 Gbps
3	CXP0, CXP1, CXP2	1 Link 3.125 Gbps, 1 Link 6.25 Gbps, 1 Link 12.5 Gbps, 2 Link 3.125 Gbps, 2 Link 6.25 Gbps, 2 Link 12.5 Gbps, 3 Link 3.125 Gbps, 3 Link 6.25 Gbps, 3 Link 12.5 Gbps
4	CXP0, CXP1, CXP2, CXP3	1 Link 3.125 Gbps, 1 Link 6.25 Gbps, 1 Link 12.5 Gbps, 2 Link 3.125 Gbps, 2 Link 6.25 Gbps, 2 Link 12.5 Gbps, 3 Link 3.125 Gbps, 3 Link 6.25 Gbps, 3 Link 12.5 Gbps, 4 Link 3.125 Gbps, 4 Link 6.25 Gbps, 4 Link 12.5 Gbps

3. Connect the device to an applicable power adapter or switching power supply via power and I/O cable. Refer to section [Power and I/O Connector](#) for details.

7.2 Install Client Software

MVS client software is used to connect and set device's parameters, and upgrade firmware.

Note

- The MVS client software is compatible with 32/64-bit Windows 7/10/11, 32/64-bit Linux, and Android 4.4 to 9.0 operating systems. Here we take Windows as an example.
- The CoaXPress line scan camera can be connected to the client software with version 3.4.0 and later.
- The graphic user interface may differ by different versions of the client software you use.
- The client software has integrated driver required by hardware, and no need to download and install other drivers.
- You can download the client software from en.hikrobotics.com.

Steps

1. Double click the MVS installation package.
2. Select the language.
3. Read and check **Terms of the License Agreement**.

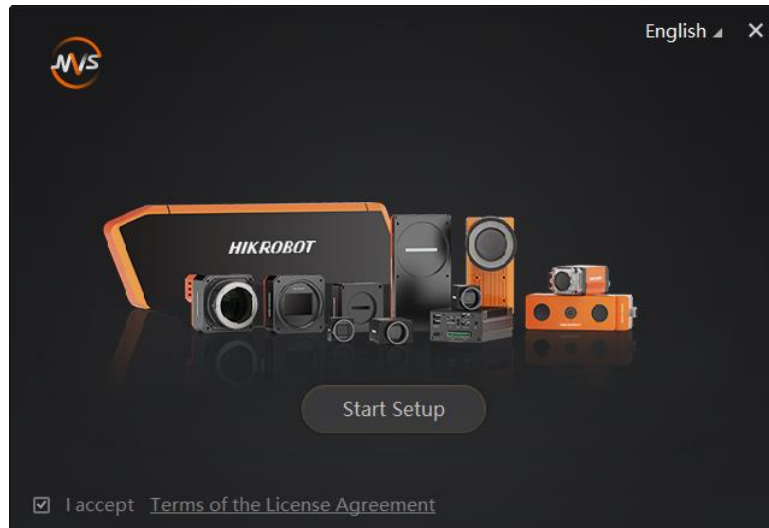

Figure 7-2 Installation Interface

4. Click **Start Setup**.
5. Select installation directory, driver and others.
 - **Select Driver:** You can check **GIGE**, **USB 3.0** and **PCIE** according to actual demands.
 - **Others:** Check **Enable built-in debug features** to make it easier to use breakpoints while the device is connected and streaming images. Check **Enable Jumbo Frame for All NICs** to enhance network transmission performance. Check **PCie-CML**, **PCie-CXP**, **PCIE-GEV**, **PCIE-XoF** to enumerate the corresponding frame grabbers.

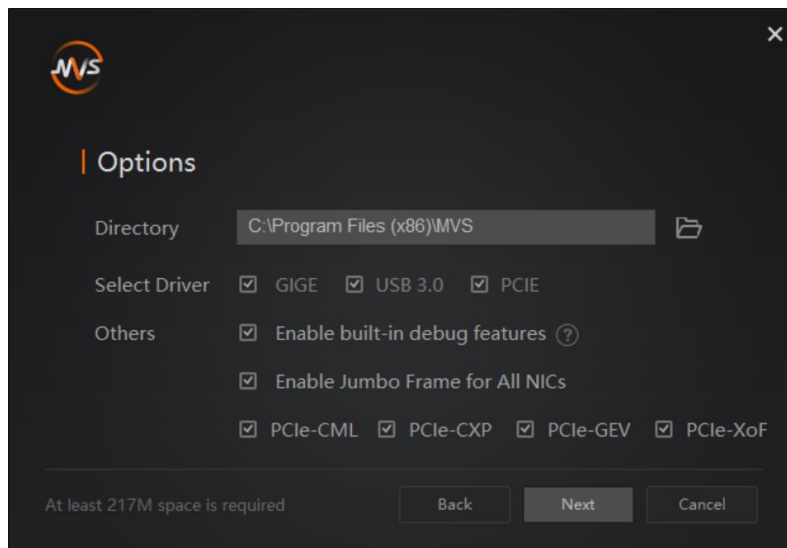

Figure 7-3 Installation Options

Note

- Regarding options, it is recommended to keep default settings.
 - **PCie-CML**, **PCie-CXP**, **PCIE-GEV**, **PCIE-XoF** can be checked only when **PCIE** is checked.
 - **PCie-CML**, **PCie-CXP**, **PCIE-GEV**, **PCIE-XoF** supports frame grabbers developed by our company only.
-



6. Click **Next** to install.
7. Finish the installation process according to the prompts.

7.3 Connect Device to Client Software

Steps

Note

Refer to the user manual of the device and client software for detailed operations.

1. Run the MVS client software.
2. Click  in **PCIe** in the device list, and the client software will enumerate the frame grabber automatically.
3. Click  in the specific frame grabber name to connect it. The client software will enumerate and connect the device under the frame grabber automatically.

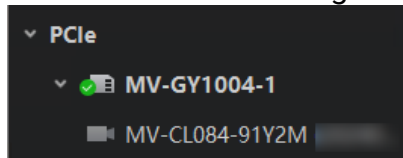

Figure 7-4 Connect Device to MVS Client Software

Note

The image is for reference only.

The client software displays the device's information after connecting, as shown below.

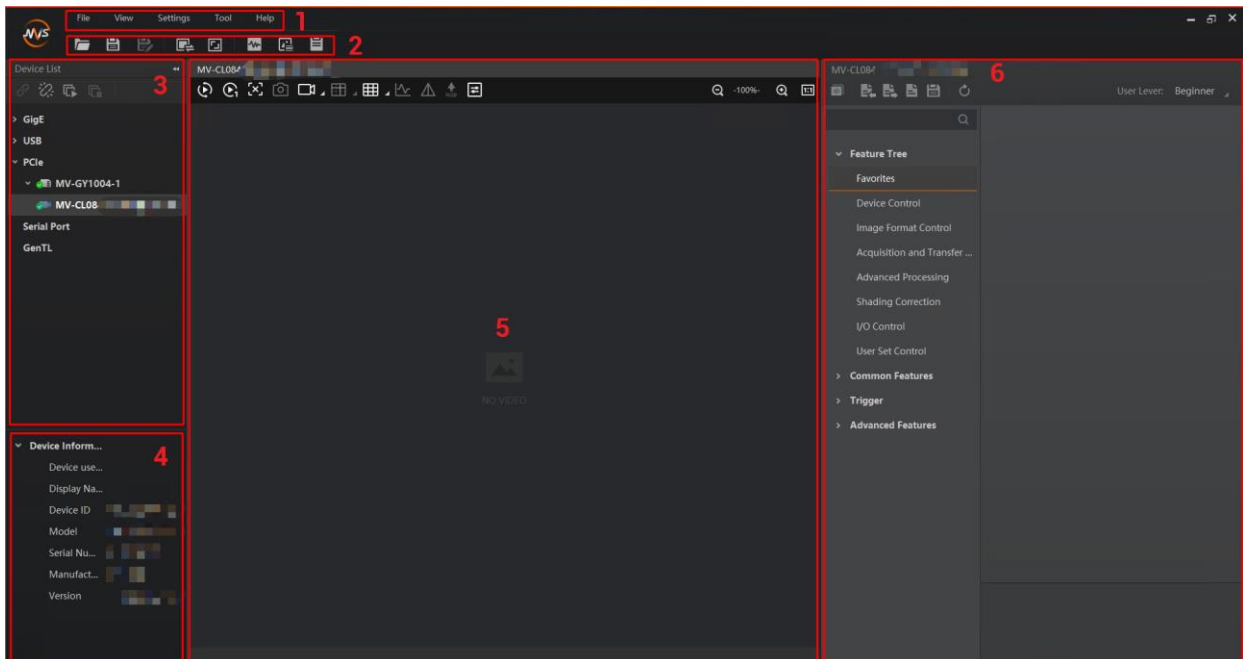



Figure 7-5 Main Window

 **Note**

For specific main window of the client software, please refer to the actual one you got.

Table 7-3 Main Window Description

No.	Name	Description
1	Menu Bar	The menu bar displays function modules, including File, View, Settings, Tool, and Help .
2	Control Toolbar	The control toolbar provides quick operations for the device, such as file function, window division, and viewing of device status, embedded information, and log.
3	Device List Panel	This panel displays the list of devices, and you can connect or disconnect device.
4	Device Information Panel	This panel displays the detailed information of connected device.
5	Display Window	This area displays the acquired images in real time. Currently, the Camera Link cameras does not support.
6	Feature Panel	This panel displays the device's parameters, and you can configure them according to actual demands.

4. Set the device's pixel format, exposure time, etc., in the feature panel.
5. Click  in the display window to acquire images continuously.
6. Set flat field correction according to the needs.
7. In the client software, capture an image and check if the image brightness is normal. If the image is too bright or too dark, you may add an additional light source, or adjust the lens aperture to improve the brightness.
8. Check whether the captured image is in focus. If not, you may perform the following steps:
 - 1) Place a legend with clear edges that can distinguish between dark and bright, and make sure the legend is in the range of the camera's field of view.
 - 2) Adjust the focus knob on the lens to ensure the dark and bright edges can be clearly distinguished.
 - 3) If the edges occupies within 3 pixels in width, it means that the image is in focus.

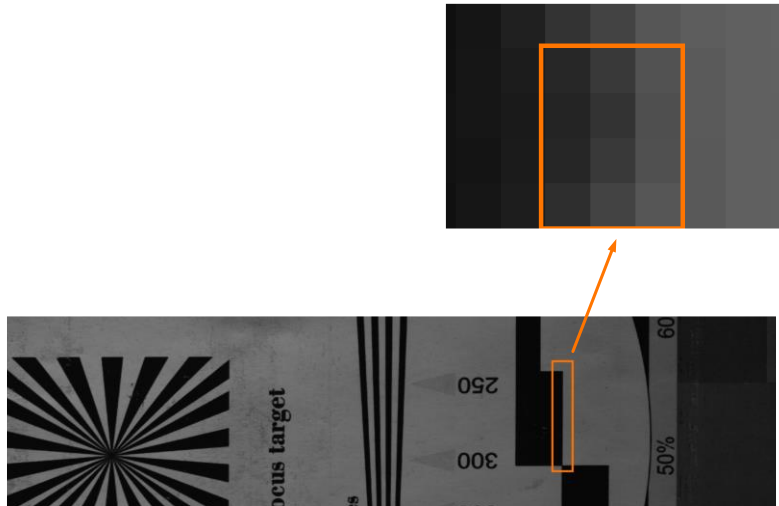

Figure 7-6 Legend

9. (Optional) Set the device's other parameters in the feature panel.

Note

The device's feature panel and parameters may differ by device models.

Chapter 8 I/O Electrical Features and Wiring

The device has 4 configurable input or output lines (Line 0/1/3/4), and these lines can be configured as differential input/output or single-ended input/output according to actual demands.

8.1 I/O Electrical Features

8.1.1 Differential Input Circuit

The differential input signal in I/O signals supports the single-ended input, and its internal circuit is shown below.

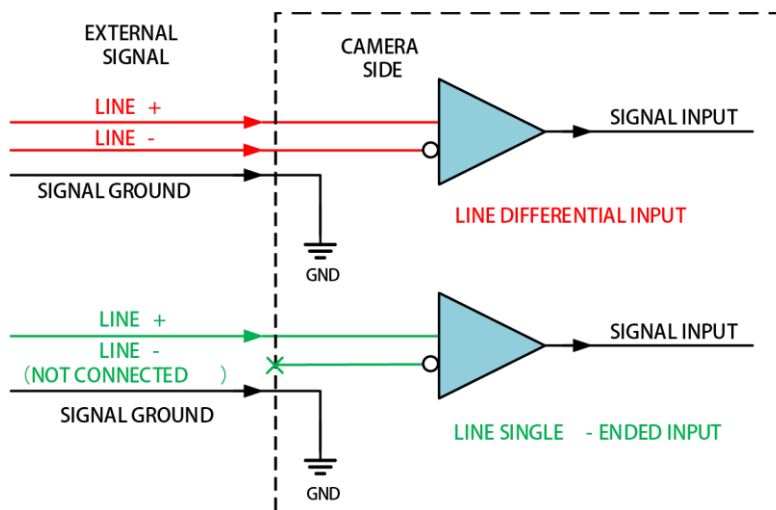

Figure 8-1 Internal Circuit of Differential Input

The RS-422 standard, RS-644 standard, and TTL & LVTTTL standard input signal are applied to the differential input.

RS-422 Standard Input

In order to make sure the normal operation of input circuit, it is required to connect device's ground signal with external ground signal if the differential input adopts RS-422 standard signal.

RS-422 standard defines the connection of the bus structure, and the inputs of several devices can be connected to the RS-422. Up to 10 devices can be connected at the same time, of which only one device is the main dispenser (D) and other devices are receivers (R). The circuit length between the receiver and the bus should be as short as possible. The bus must have a 120 Ω terminal resistance (RT).

When the device is the last receiver on the bus structure, the device's terminal resistance

needs to be enabled, and the rest device's terminal resistances need to be disabled. Multiple terminal resistance should not be enabled on the bus structure, which will reduce signal reliability and may cause damage to the RS-422 device.

RS-644 Standard Input

If the differential input adopts RS-644 standard signal, the input terminal's 120 Ω terminal resistance should be enabled.

TTL & LVTTTL Standard Input

If the differential input adopts TTL & LVTTTL standard signal, the input terminal's 120 Ω terminal resistance should be disabled, and its input electrical feature requirement is shown below.

Table 8-1 Electrical Feature Requirement of TTL & LVTTTL

Voltage Range	Description
0 V to 1 V	Level low
1 V to 3 V	Unstable voltage, and it is not recommended to use it.
3.3 V to 24 V	Level high

8.1.2 Differential Output Circuit

The internal circuit of differential output signal in I/O signals is shown below.

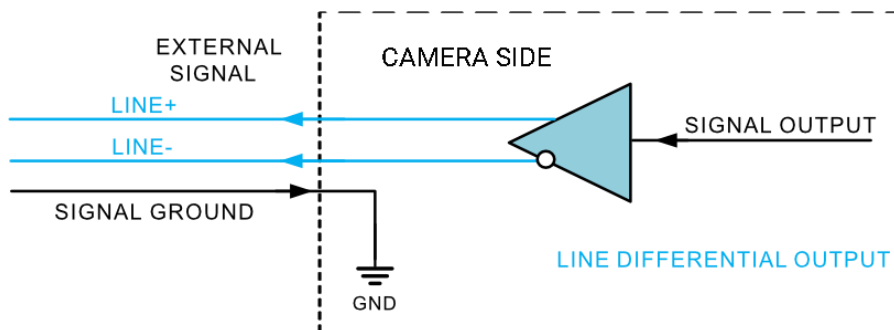

Figure 8-2 Internal Circuit of Differential Output

The RS-422 standard and RS-644 standard are applied to the differential output.

RS-422 Standard Output

In order to make sure the normal operation of output circuit, it is required to connect device's ground signal with external ground signal. The output interface can be connected to the RS-422 bus structure as a main dispenser.

RS-644 Standard Output

The device adopting RS-422 standard output signal cannot directly connect to RS-644 standard. When connecting RS-644 standard output, it is required to add a resistance network in device's output location. In order to make sure the normal operation of output circuit, it is required to connect device's ground signal with external ground signal.

8.2 Signal Wiring

8.2.1 Input Signal Wiring

The device can receive input signals via the hardware trigger to acquire images. The input signals include differential signal and single-ended signal.

 **Note**

- Make sure that the hardware trigger signals have been configured as input signal.
 - Signal source means the device that is directly connected to the device's I/O.
 - It is recommended to connect Line 1 and Line 3 if the device uses line trigger mode.
 - It is recommended to connect Line 0 if the device uses frame trigger mode.
-

The wiring is shown below if the differential signal source provides trigger signal.

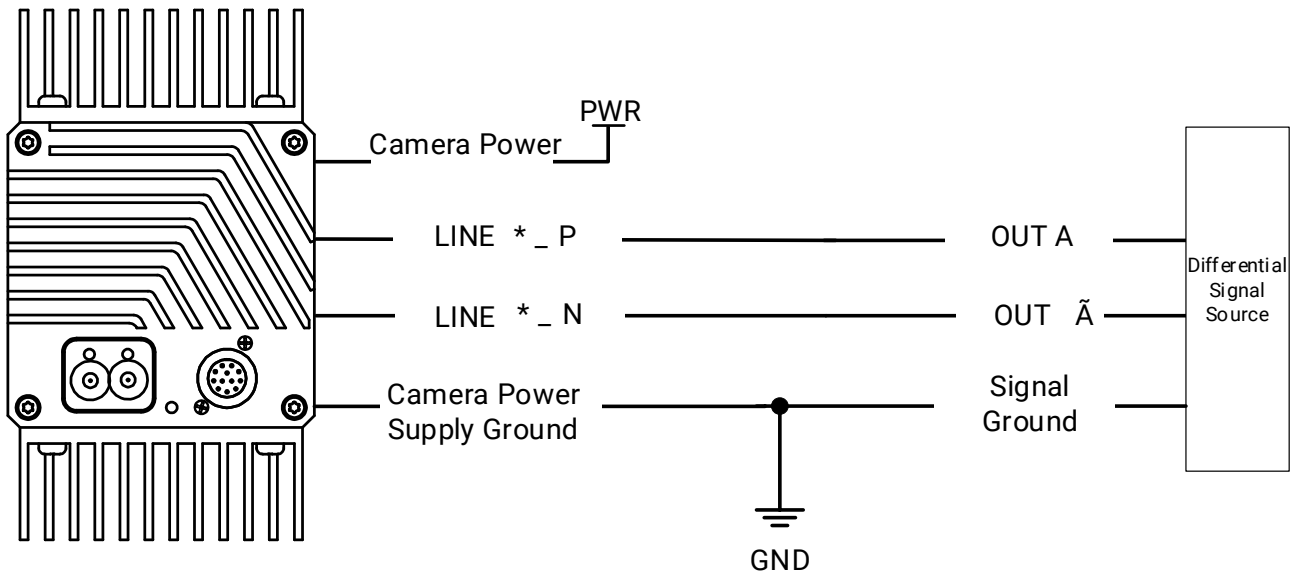

Figure 8-3 Differential Input Wiring

Note

The device's power supply ground should connect the signal ground of the differential signal source if the differential signal source provides signal.

If the PNP single-ended signal source provides signal, there are two different wirings as shown below.

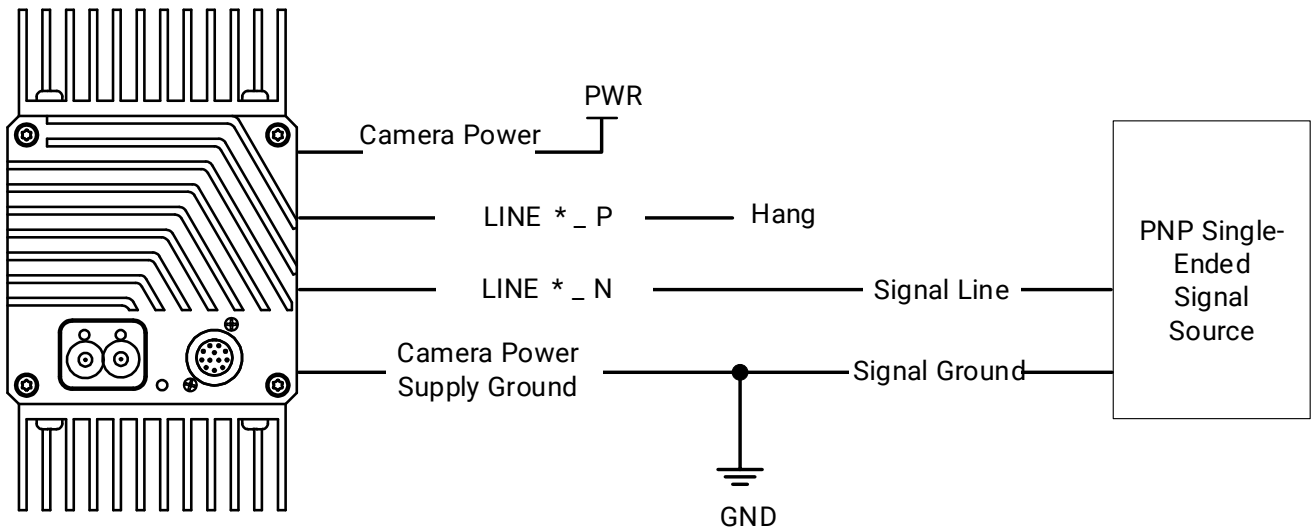

Figure 8-4 PNP Single-Ended Input Wiring Without Pull-Down Resistor

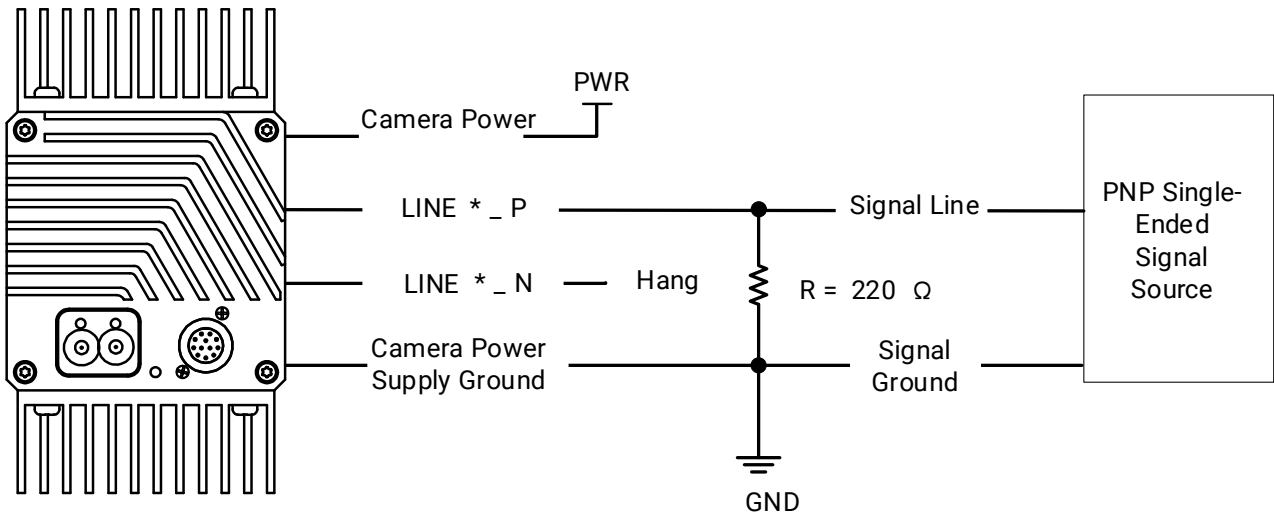

Figure 8-5 PNP Single-Ended Input Wiring with Pull-Down Resistor

If the NPN single-ended signal source provides signal, there are two different wirings as shown below.

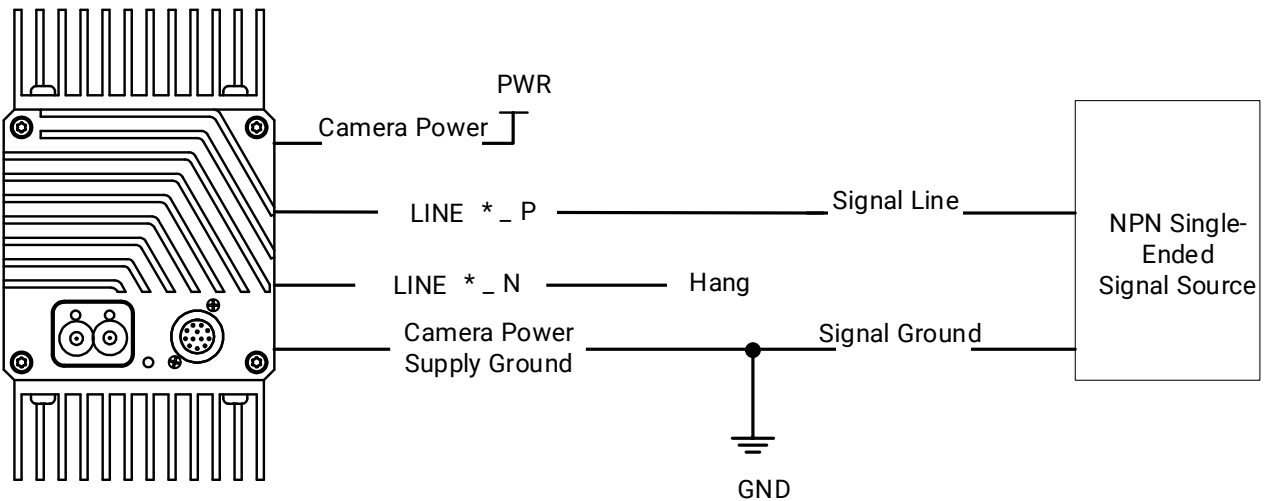

Figure 8-6 NPN Single-Ended Input Wiring Without Pull-Up Resistor

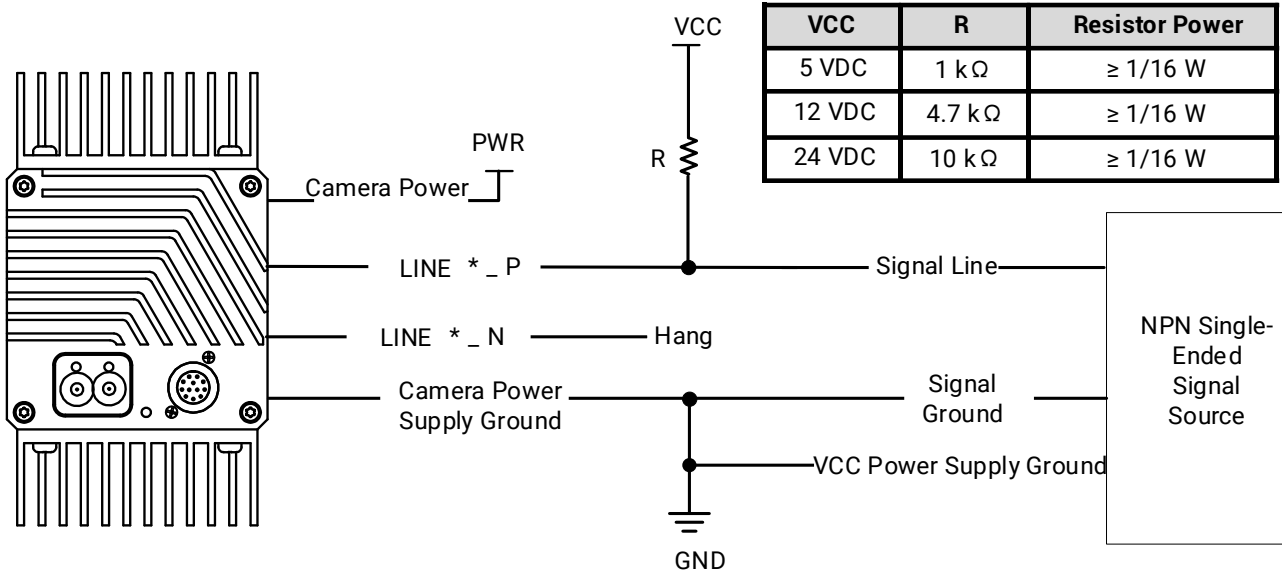

Figure 8-7 NPN Single-Ended Input Wiring with Pull-Up Resistor

Note

The power range of R is $\geq 1/16$ W.

8.2.2 Output Signal Wiring

The device's 4 configurable lines can be configured to output signal to trigger other devices.

Note

Wiring varies depending on I/O signal is configured as differential output or single-ended output.

If I/O signals are used as differential output, the wiring is shown below.

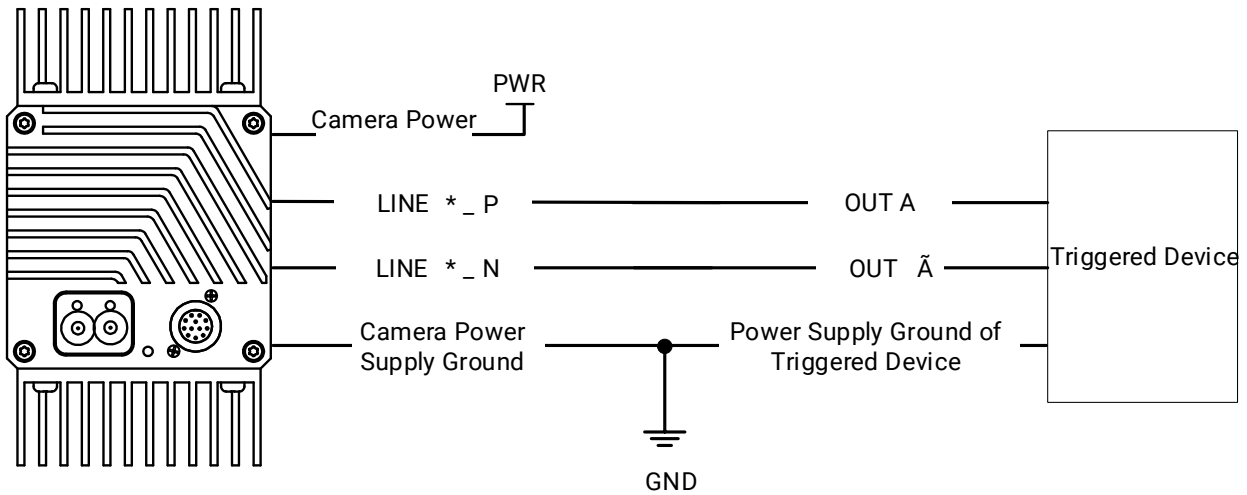

Figure 8-8 Differential Output Wiring

If I/O signals are used as single-ended output, the triggered device needs to be triggered at a LVTTTL level of 3.3 VDC or more. At this time, a pull-up resistor of 1 kΩ to 10 kΩ needs to be added.

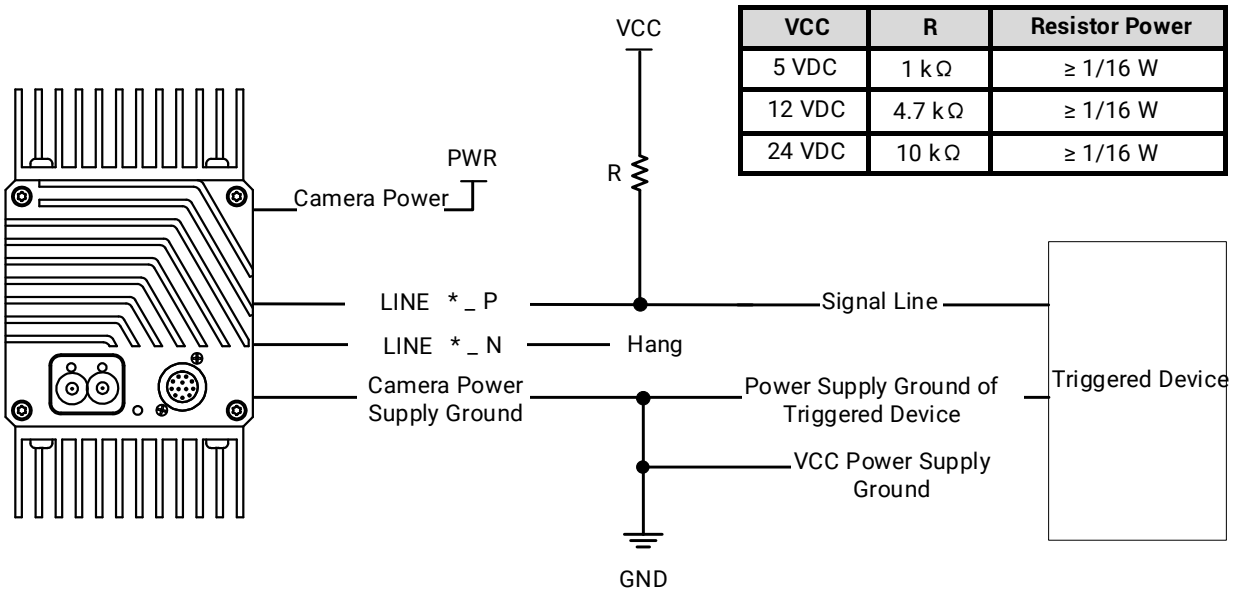

Figure 8-9 Single-Ended Output Wiring with Pull-Up Resistor

Note

- The power range of R is $\geq 1/16$ W.
- The VCC voltage value should match the required trigger voltage value.
- It is recommended that VCC use device power or triggered device power. If a third-party power supply is used, the power supply should be shared with the device power supply and the triggered device power supply.

Chapter 9 Trigger Input and Output

9.1 Trigger Input

9.1.1 Set Trigger Mode

The device has 4 types of trigger modes, including internal trigger mode, line trigger mode, frame trigger mode, and line + frame trigger mode. The trigger mode is controlled by **Scan Mode** in **Acquisition and Transfer Control**, **FrameTrigger Mode** in **Frame Trigger Control**, and **LineTrigger Mode** in **Line Trigger Control**.

Note

The **Frame Trigger Control** can be set only if the **Frame Scan** is selected as **Scan Mode**.

Table 9-1 Trigger Mode Description

Trigger Mode	Scan Mode Parameter	FrameTrigger Mode Parameter	LineTrigger Mode Parameter	Description
Internal Trigger	Line Scan	/	Off	The device acquires images per lines via its internal signal and outputs images per frames according to configured parameters.
	Frame Scan	Off	Off	
Line Trigger	Line Scan	/	On	The device acquires images per lines via the external signal and outputs images per frames according to configured parameters.
	Frame Scan	Off	On	
Frame Trigger	Frame Scan	On	Off	The device acquires images after receiving the external signal, and acquires images per lines via its internal signal.
Line + Frame Trigger	Frame Scan	On	On	The device acquires images after receiving the external signal, and acquires images per lines via another external signal.

9.1.2 Set Trigger Source

The device’s trigger source includes software trigger, hardware trigger, shaft encoder control, frequency converter control, anyway mode, and link trigger. Refer to the tables below to see the trigger source under frame trigger mode or in line trigger mode.

 **Note**

- The specific trigger source may differ by device models.
- The trigger sources in the tables below are valid for frame trigger mode, line trigger mode, or line + frame trigger mode.
- In line + frame trigger mode, when the trigger source selected by the frame trigger and the line trigger and the trigger-related parameters are the same, the first signal of trigger source will be used as the frame trigger signal to make the device start to acquire images, and the subsequent signals as line trigger signal to acquire images per lines until the processing of one frame of image is completed, and then the processing of the next frame of image is performed.

Table 9-2 Trigger Source Description in Frame Trigger Mode

External Trigger Source	Path	Parameter	Description
Software Trigger	Acquisition and Transfer Control → Frame Trigger Control → FrameTrigger Source	Software	The software sends trigger signal to the device via CoaXPress interface to acquire images.
Hardware Trigger		Line *	External device connects to the device via device I/O interface. External device sends trigger signal to device to acquire images.
Frequency Converter Control		Frequency Converter	This trigger source sends trigger signal to the device through frequency conversion to acquire images.
Anyway Mode		Anyway	This trigger source uses trigger sources mentioned above to send trigger signal to the device to acquire images.
Link Trigger		Link Trigger*	The frame grabber sends trigger signal to the device to acquire images.

Table 9-3 Trigger Source Description in Line Trigger Mode

External Trigger Source	Path	Parameter	Description
Hardware Trigger	Acquisition and Transfer Control →	Line *	External device connects to the device via device I/O interface. External device sends trigger signal to device to acquire images.

External Trigger Source	Path	Parameter	Description
Shaft Encoder Control	Line Trigger Control → LineTrigger Source	Encoder Module Out	This trigger source sends trigger signal to the device through shaft encoder module to acquire images.
Frequency Converter Control		Frequency Converter	This trigger source sends trigger signal to the device through frequency conversion to acquire images.
Anyway Mode		Anyway	This trigger source uses trigger sources mentioned above to send trigger signal to the device to acquire images.
Link Trigger		Link Trigger*	The frame grabber sends trigger signal to the device to acquire images.

Set and Execute Software Trigger

The software trigger is valid when the frame trigger is enabled.

Steps

1. Go to **Acquisition and Transfer Control** → **Scan Mode**, and select **Frame Scan**.
2. Enable **FrameTrigger Mode** in **Acquisition and Transfer Control** → **Frame Trigger Control**.
3. Select **Software** as **FrameTrigger Source**.
4. Click **Execute** in **FrameTrigger Software**.

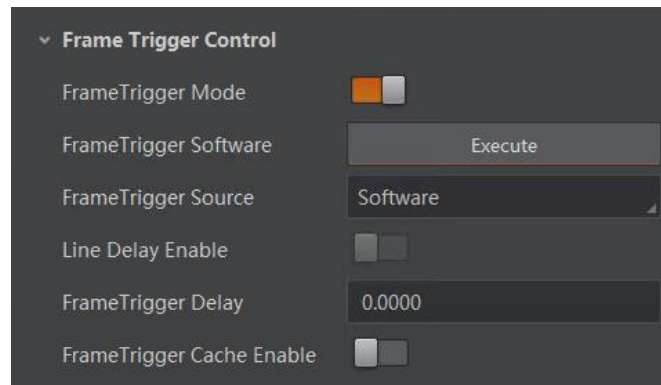

Figure 9-1 Set and Execute Software Trigger

Note

Refer to section [Set Trigger Related Parameters](#) for parameters that can be configured in the trigger source.

Set and Execute Hardware Trigger

The hardware trigger is valid when the frame trigger or line trigger is enabled. In hardware trigger, external device sends trigger signal to the device to acquire images via I/O connector.

Steps

1. Go to **Acquisition and Transfer Control** → **Scan Mode**, and select **Frame Scan** or **Line Scan**.
 2. Enable **FrameTrigger Mode** in **Frame Trigger Control** or **LineTrigger Mode** in **Line Trigger Control**.
-

Note

The **Frame Trigger Control** can be set only if the **Frame Scan** is selected as **Scan Mode**.

3. Select **Line *** as **FrameTrigger Source** or **LineTrigger Source** according to actual demands.

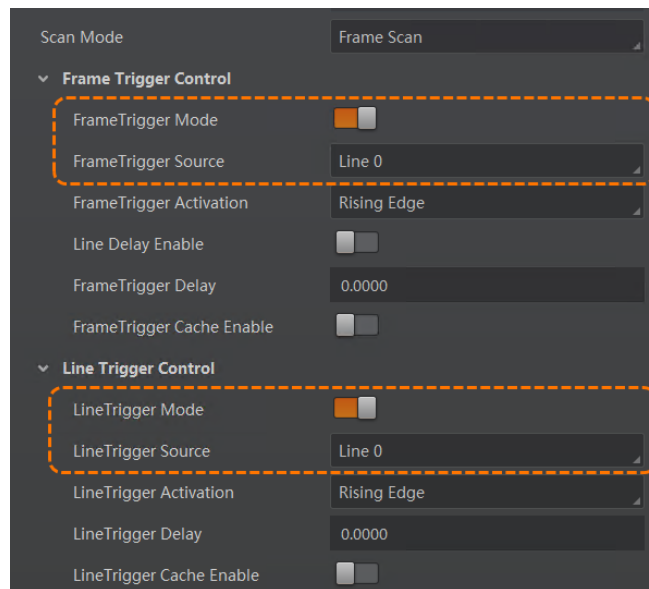

Figure 9-2 Set and Execute Hardware Trigger

Note

Refer to section [Set Trigger Related Parameters](#) for parameters that can be configured in the trigger source.

When selecting bi-directional configurable line as the hardware trigger source, you need to make sure that its line mode is input. Go to **I/O Control**, select specific line as **Line Selector**, and **Input** as **Line Mode**.

Note

Here we take Line 1 as an example to introduce how to set bi-directional configurable line as the hardware trigger source. Refer to the device you got for the actual condition.

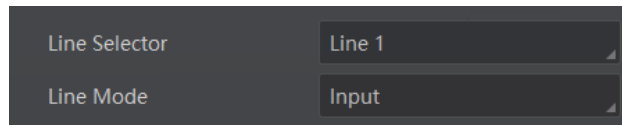

Figure 9-3 Line Selector

You can also set the signal type for the selected bi-directional configurable line. Go to **I/O Control**, and set **Line Format** according to actual demands.

- **SingleEnded**: It can receive single-ended input signal.
 - **Differential**: It can receive TTL & LVTTTL standard input signal.
-

Caution

You need to select line format according to the external device connected. Otherwise, I/O may be damaged.

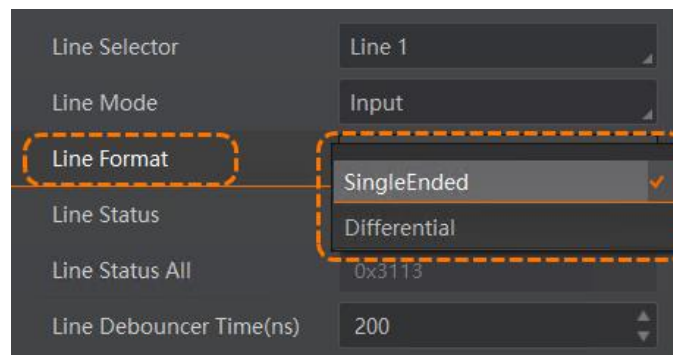

Figure 9-4 Set Line Format

Set and Execute Shaft Encoder Control

If the device enables the line trigger, you can select shaft encoder control as trigger source. At this time, the device will receive signal A and signal B with phase difference. The function demonstration of shaft encoder module is shown below.

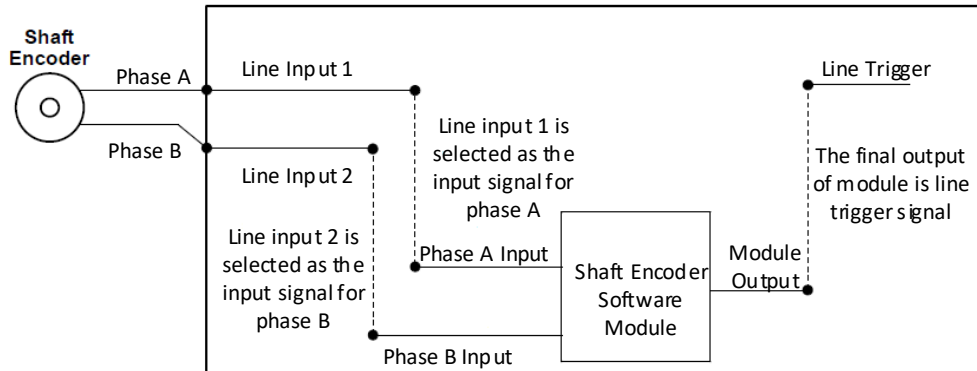

Figure 9-5 Function Demonstration

The advantages of shaft encoder are as follows:

- Encoder output pulse frequency is proportional to rotating speed.
- The output pulse acts as a trigger signal for line scan device.
- Synchronize acquisition speed and sample movement of device.
- Non-uniform motion can also be a perfect match.
- A trigger signal can be set as acquiring multiple lines or multiple frames with adjustable ratio.

Follow steps below to set shaft encoder control.

Steps

1. Click **Encoder Control**, and set **Encoder Source A** and **Encoder Source B** according to actual demands.

Note

It is recommended to select different signal sources for source A and source B. If the same signal source is selected for A and B, the shaft encoder will not output the signal.

2. Set **Encoder Trigger Mode**.

- **Any Direction** means that both forward and backward direction will trigger.
- **Forward Only** mean that only forward direction will trigger.
- **Backward Only** mean that only backward direction will trigger.

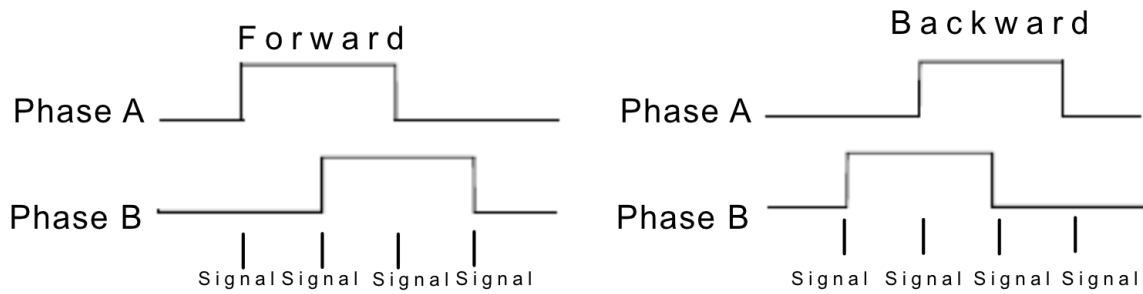

Figure 9-6 Process Logic

Note

Phase A and phase B of the encoder corresponds 4 signals each, as shown below.

3. Set **Encoder Counter Mode**.

- **Ignore Direction** means that both forward and backward direction will count.
- **Follow Direction** means that the forward direction is valid, and **Encode Counter** will increase.
- **Backward Direction** means that the backward direction is valid, and **Encode Counter** will increase.

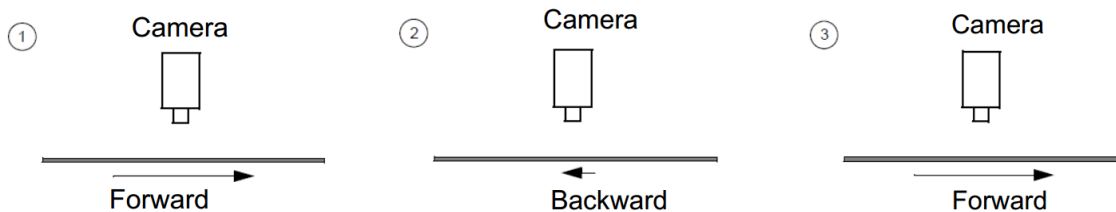

Figure 9-7 Counter Description

4. (Optional) Set max. counter value in **Encoder Counter Max**.

Note

- The range of **Encoder Counter Max**. may differ by device models.
- After reaching the max. value, it will be cleared automatically or you can clear manually by clicking **Encoder Counter Reset**.

5. (Optional) Set **Encoder Max Reverse Counter** to avoid outputting images if the object moves backward accidentally during measurement, and click **Execute** in **Encoder Reverse Counter Reset** to let the device to output images again.

Set and Execute Frequency Converter Control

If the device enables the frame trigger or the line trigger, you can select Frequency Converter as trigger source. The hardware signal trigger or shaft encoder control signal can be converted into the signal frequency of frame trigger or line trigger by device's frequency converter module.

The frequency converter module includes PreDivider, Multiplier, and PostDivider.

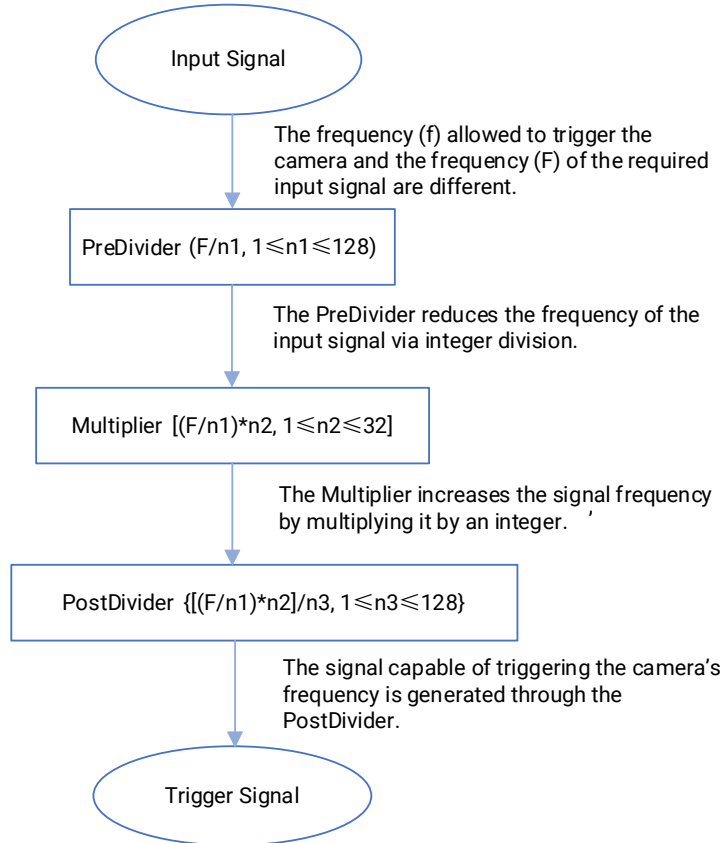

Figure 9-8 Encoder Frequency Converter Control

PreDivider

The input signal first enters the PreDivider module, which reduces source signal frequency via integer division, and then the signal is sent to the Multiplier module.

The PreDivider module reduces periodic jitter on the input signal, and signals above 100 kHz must go through the PreDivider module to reduce the frequency for the Multiplier can only receive signals in the range of 10 Hz to 100 kHz frequency range. The periodic jitter of shaft encoder signal is accepted.

Multiplier

After the signal is processed by the PreDivider, it is sent to the Multiplier. The Multiplier multiplies the signal by an integer to increase its signal frequency, and then the signal is sent to the PostDivider.

Parameter can be set as rising or falling edge. If a rising edge is set, each rising edge of

the signal coming from the PreDivider will be locked to match the signal of the rising edge, and vice versa.

During this process, make sure do not increase signal frequency via too larger multipliers to avoid trigger signal frequency beyond the max. line rate of the device. Even if a smaller multiplier is selected, an excessively high frequency may be generated in the frequency adjustment, exceeding the max. line rate of the device.

PostDivider

PostDivider reduces signal frequency via an integer factor, and uses the newly generated frequency signal as the device's trigger signal.

Follow steps below to set frequency converter control.

Steps

1. Click **Frequency Converter Control**, and select specific line, **Encoder Module Out** or **N/A** as **Input Source** according to actual demands.

Note

N/A means that the signal source is not selected.

2. Set **Rising Edge** or **Falling Edge** as **Signal Alignment** according to actual demands.
3. Set **PreDivider**, **Multiplier** and **PostDivider**.

The device supports displaying trigger line rate.

Note

- Parameters of trigger line rate and resulting trigger line rate may differ by device models.
 - Make sure that line trigger is enabled and input source value of frequency converter control and trigger source value of acquisition control is the same before viewing trigger line rate.
 - The trigger line rate is valid when the external trigger source is selected as the **Input Source**. If N/A is selected, the trigger line rate is 0.
-
- **Trigger Line Rate:** It refers to the external trigger raw line rate after filtering, and it only involves external trigger signals.
 - **Resulting Trigger Line Rate:** It refers to the external trigger frequency devices received after the external trigger raw line rate is calculated via frequency converter control. It only involves external trigger signals.
-

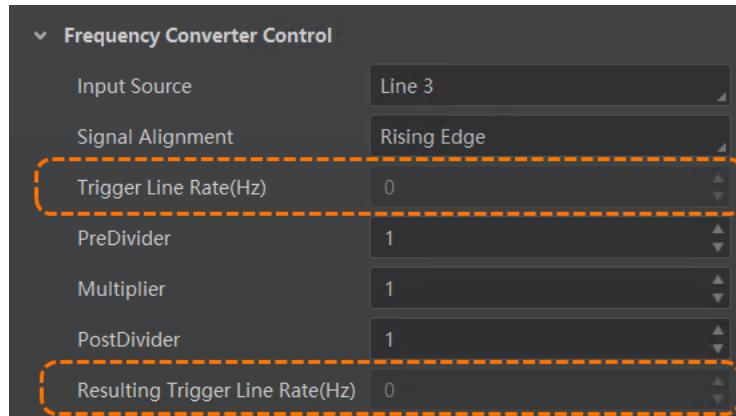

Figure 9-9 View Trigger Line Rate

Set and Execute Anyway Mode

When the device enables the frame trigger or the line trigger, you can select Anyway as trigger source. In anyway mode, the device can receive all trigger source signals to acquire images.

Steps

1. Go to **Acquisition and Transfer Control** → **Scan Mode**, and select **Frame Scan** or **Line Scan**.
2. Enable **FrameTrigger Mode** in **Frame Trigger Control** or **LineTrigger Mode** in **Line Trigger Control**.
3. Select **Anyway** as **FrameTrigger Source** or **LineTrigger Source**.

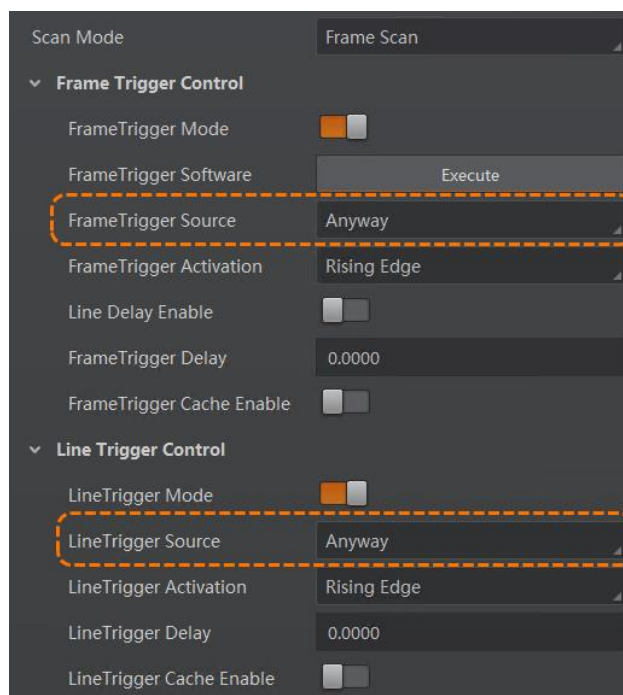

Figure 9-10 Set and Execute Anyway Mode

Note

Refer to section [Set Trigger Related Parameters](#) for parameters that can be configured in the trigger source.

Set and Execute Link Trigger

When the device enables the frame trigger or the line trigger, you can select **Link Trigger*** as trigger source. In link trigger, the CoaXPress frame grabber sends trigger signal to the device to acquire images.

Steps

1. Go to **Acquisition and Transfer Control** → **Scan Mode**, and select **Frame Scan** or **Line Scan**.
2. Enable **FrameTrigger Mode** in **Frame Trigger Control** or **LineTrigger Mode** in **Line Trigger Control**.
3. Select **Link Trigger*** as **FrameTrigger Source** or **LineTrigger Source**.

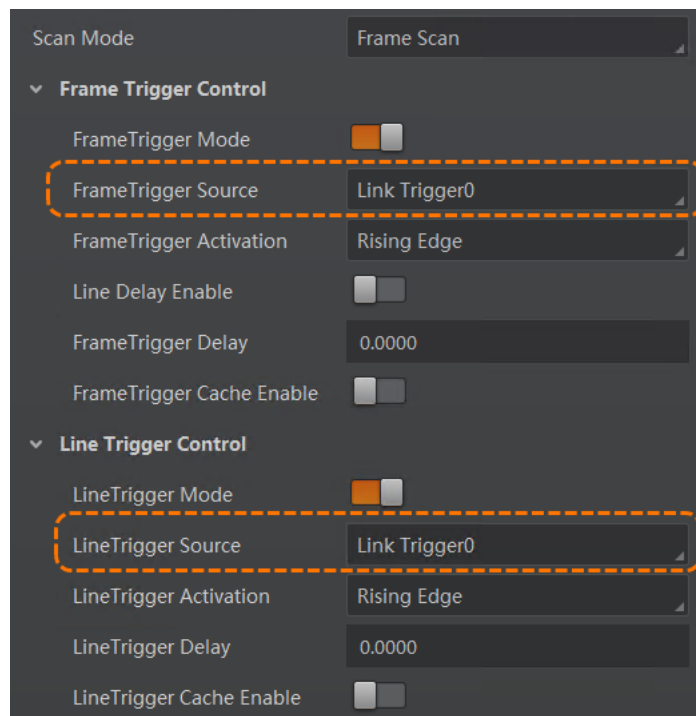

Figure 9-11 Set and Execute Link Trigger

Note

- Refer to section [Set Trigger Related Parameters](#) for parameters that can be configured in the trigger source.
 - Refer to frame grabber user manual for frame grabber trigger.
-

9.1.3 Set Trigger Related Parameters

When the line trigger mode or frame trigger mode is enabled, you can set some related parameters, including acquisition burst frame count, trigger delay, trigger cache, trigger activation, and trigger debouncer.

 **Note**

- Different trigger sources and trigger modes can set various parameters.
- Frame trigger cache and line trigger cache may differ by device models.
- √ is supported, and × is not supported.

If the frame trigger is enabled, the relation between trigger source and trigger related parameters is shown below.

Table 9-4 Trigger Source and Trigger Related Parameters in Frame Trigger Mode

Trigger Source Trigger Parameters	Software Trigger	Hardware Trigger	Frequency Converter Control	Anyway Mode	Link Trigger
Acquisition Burst Frame Count	√	√	√	√	√
Frame Trigger Activation	×	√	√	√	√
Frame Trigger Cache	√	√	√	√	√
Trigger Debouncer	×	√	×	×	×

If the line trigger is enabled, the relation between trigger source and trigger related parameters is shown below.

Table 9-5 Trigger Source and Trigger Related Parameters in Line Trigger Mode

Trigger Source Trigger Parameters	Hardware Trigger	Shaft Encoder Control	Frequency Converter Control	Anyway Mode	Link Trigger
Line Trigger Activation	√	√	√	√	√
Line Trigger Cache	√	√	√	√	√
Trigger Debouncer	√	×	×	×	×

Note

When the frame trigger mode and the line trigger mode are enabled at the same time, the trigger delay is supported for all frame trigger sources and line trigger sources.

Set Acquisition Burst Frame Count

In frame trigger mode, you can set acquisition burst frame count. Go to **Acquisition and Transfer Control** → **Acquisition Burst Frame Count**, and enter **Acquisition Burst Frame Count** according to actual demands.

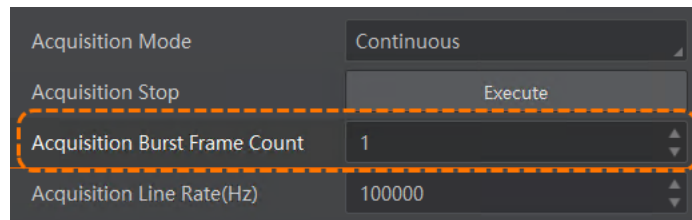

Figure 9-12 Set Acquisition Burst Frame Count

Note

- The range of **Acquisition Burst Frame Count** is from 1 to 1023.
- If **Acquisition Burst Frame Count** is 1, the device is in single frame trigger mode. If **Acquisition Burst Frame Count** is larger than 1, the device is in multi-frame trigger mode.
- If **Acquisition Burst Frame Count** is n, when input 1 trigger signal to the device, the device stops acquiring images after exposing n times and outputting n frame images.
- The sequence diagram below uses rising edge as trigger activation.
- The sequence diagram above uses rising edge as trigger activation, and the device's height parameter is 4.

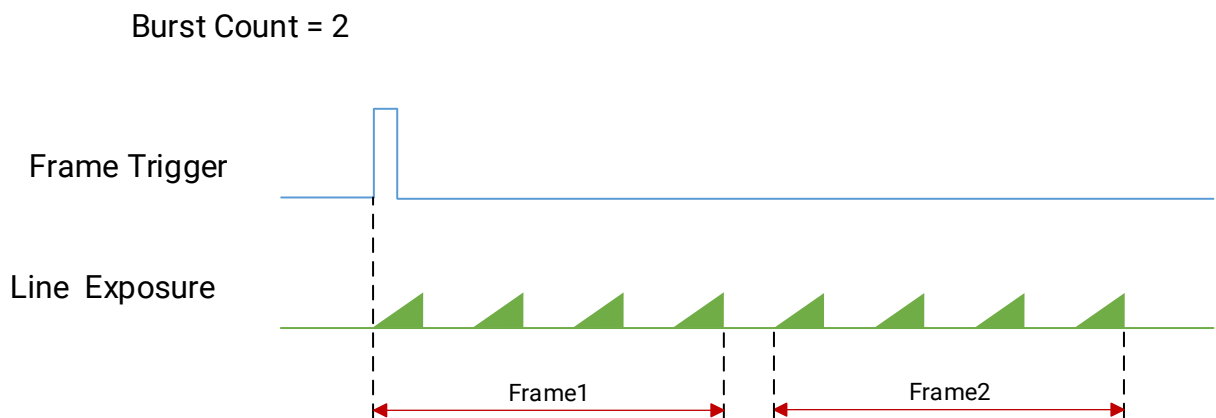

Figure 9-13 Sequence Diagram of Acquisition Burst Frame Count

Set Trigger Activation

The device supports triggering image acquisition in the rising edge, falling edge, level high, level low, or any edge of the external signal.

- **Rising Edge:** It means that when the level signal sent by external device is in rising edge, the device receives trigger signal and starts to acquire images.
- **Falling Edge:** It means that when the level signal sent by external device is in falling edge, the device receives trigger signal and starts to acquire images.
- **Any Edge:** It means that when the level signal sent by external device is in rising or falling edge, the device receives trigger signal and starts to acquire images.
- **Level High:** The level high of the trigger signal is valid. As long as the trigger signal is in level high, the device is in image acquisition status.
- **Level Low:** The level low of the trigger signal is valid. As long as the trigger signal is in level low, the device is in image acquisition status.

Note

The setting method for trigger activation is different in frame trigger and line trigger.

Set Trigger Activation in Frame Trigger

Go to **Acquisition and Transfer Control** → **Frame Trigger Control**, and set **FrameTrigger Activation** according to actual demands.

- When rising edge, falling edge, or any edge is selected as **FrameTrigger Activation**, you can set trigger delay. When **Line Delay Enable** is enabled, set the number of trigger lines for delay in the **FrameTrigger Delay**, or when the **Line Delay Enable** is disabled, set the trigger time for delay in the **FrameTrigger Delay**.

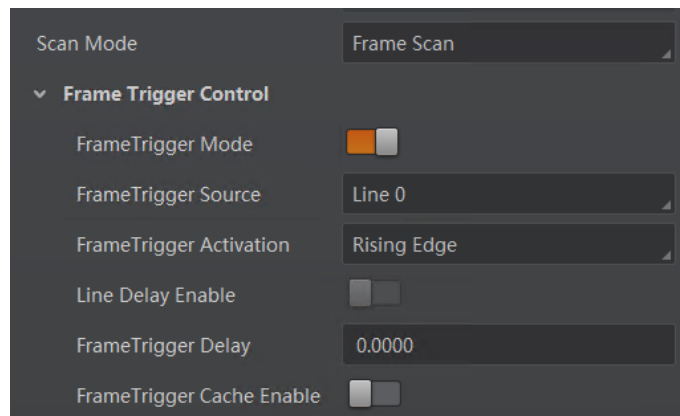

Figure 9-14 Set Trigger Activation in Frame Trigger

Note

The **Line Delay Enable** is valid only when the line trigger mode is enabled.

- When level high or level low is selected as **FrameTrigger Activation**, the device will be triggered according to selected method.

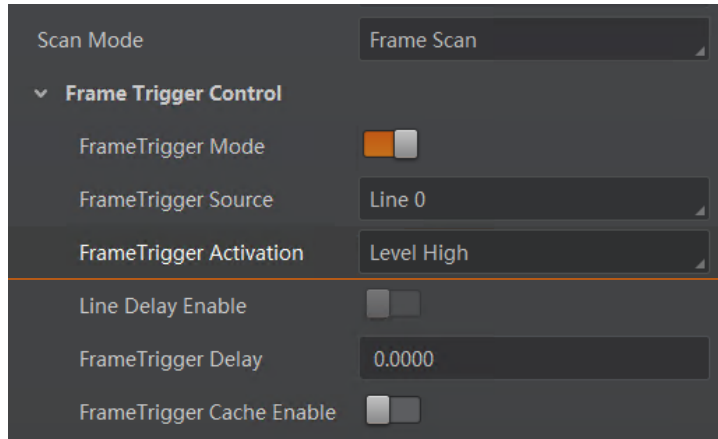

Figure 9-15 Level Trigger in Frame Trigger

Note

When Line 0/1/3 is selected as the trigger source in the frame trigger mode, the images are output during the level high by default.

Set Trigger Activation in Line Trigger

Go to **Acquisition and Transfer Control** → **Line Trigger Control**, and set **LineTrigger Activation** according to actual demands.

In the line trigger mode, the trigger activation is related with **Exposure Mode**.

- When you select **Rising Edge**, **Falling Edge**, or **Any Edge** as **LineTrigger Activation**, you can select **Timed** as **Exposure Mode** only, and **Exposure Auto** and **Exposure Time** determine the exposure time.
- When you select **Level Low** or **Level High** as **LineTrigger Activation**, you can select **Timed** or **Trigger Width** as **Exposure Mode**. Exposure time is determined by the duration of the level signal only if **Trigger Width** is selected.

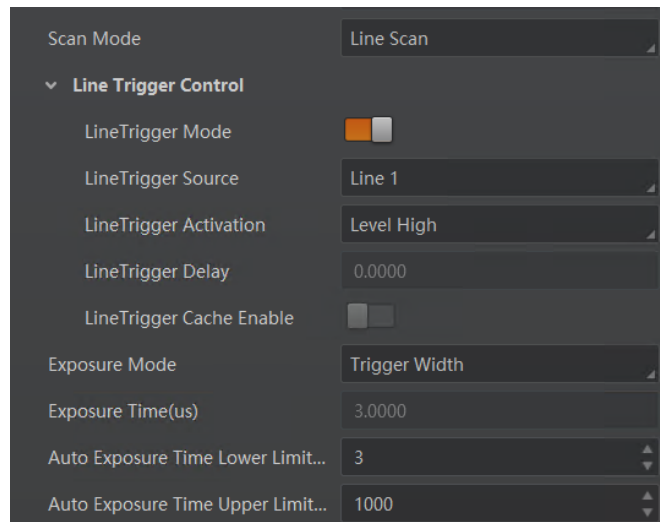

Figure 9-16 Set Trigger Activation in Line Trigger

Note

The trigger width function may differ by device models.

Set Trigger Cache

Note

- The trigger cache in frame trigger or line trigger modes may differ by device models.
 - The setting method for trigger cache is different in frame trigger and line trigger.
-

If the device enables the frame trigger or line trigger, it has the frame/line trigger cache function. During the triggering process, if the device receives new trigger signal, it will save and process the signal if you enable this function. Trigger cache enable can save up to 3 trigger signals.

Set Trigger Cache in Frame Trigger

Go to **Acquisition and Transfer Control** → **Frame Trigger Control**, and enable **FrameTrigger Cache Enable**.

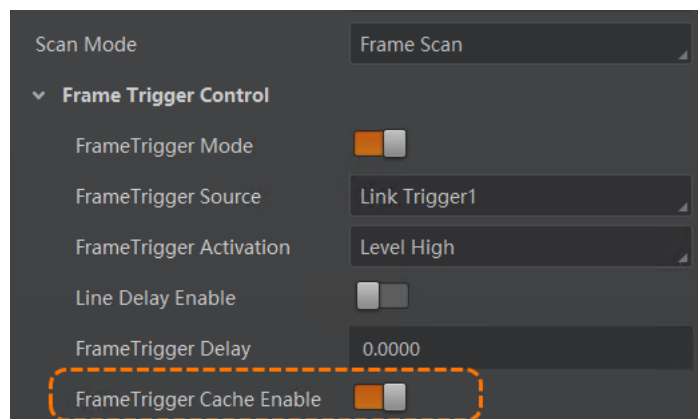

Figure 9-17 Set Trigger Cache in Frame Trigger

If the device receives the 1st trigger signal first, and the device receives the 2nd trigger signal during processing the 1st trigger signal.

- Disable Trigger Cache Enable: the 2nd trigger signal will be filtered without processing.

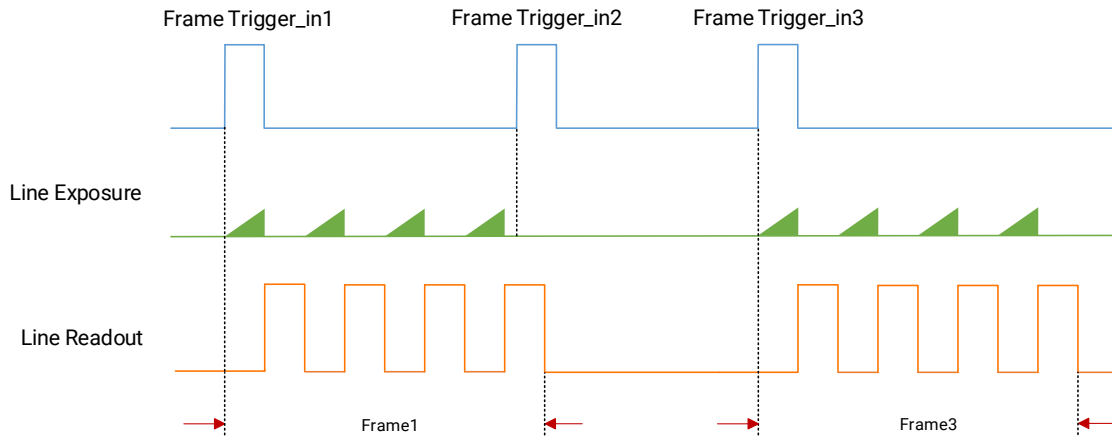

Figure 9-18 Second Frame Filtered

- Enable Trigger Cache Enable: the 2nd trigger signal will be saved. If the 1st frame image's exposure time of the 2nd trigger signal is not earlier than the device's last frame creation time of the 1st trigger signal, and then the 2nd trigger signal's 1st frame image is created normally.

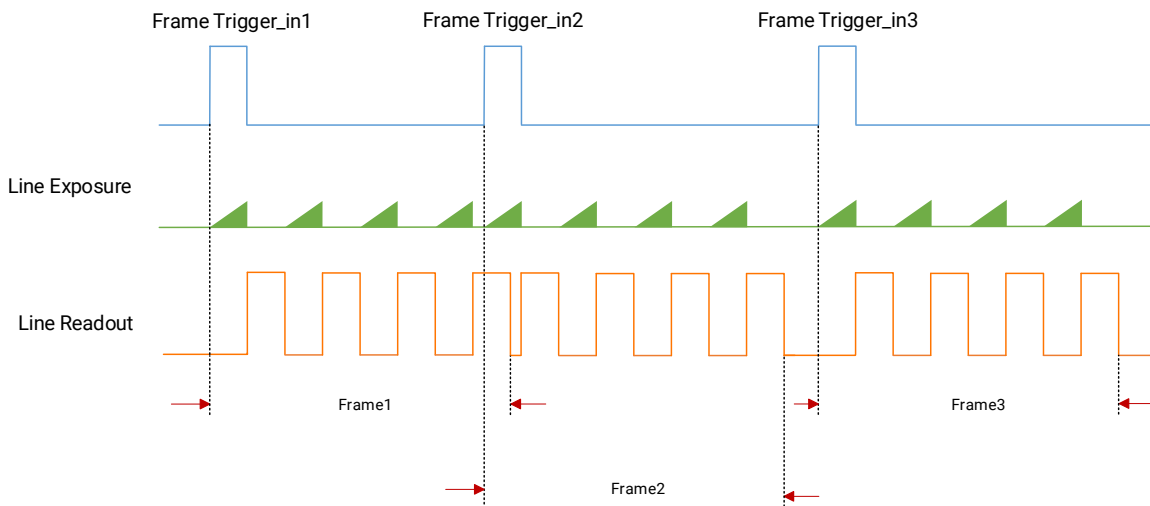

Figure 9-19 Second Frame Created Normally

If the 1st frame image's exposure time of the 2nd trigger signal is earlier than the device's last frame creation time of the 1st trigger signal, and then the device will delay this exposure time. Make sure this exposure time is not earlier than the device's last frame creation time of the 1st trigger signal.

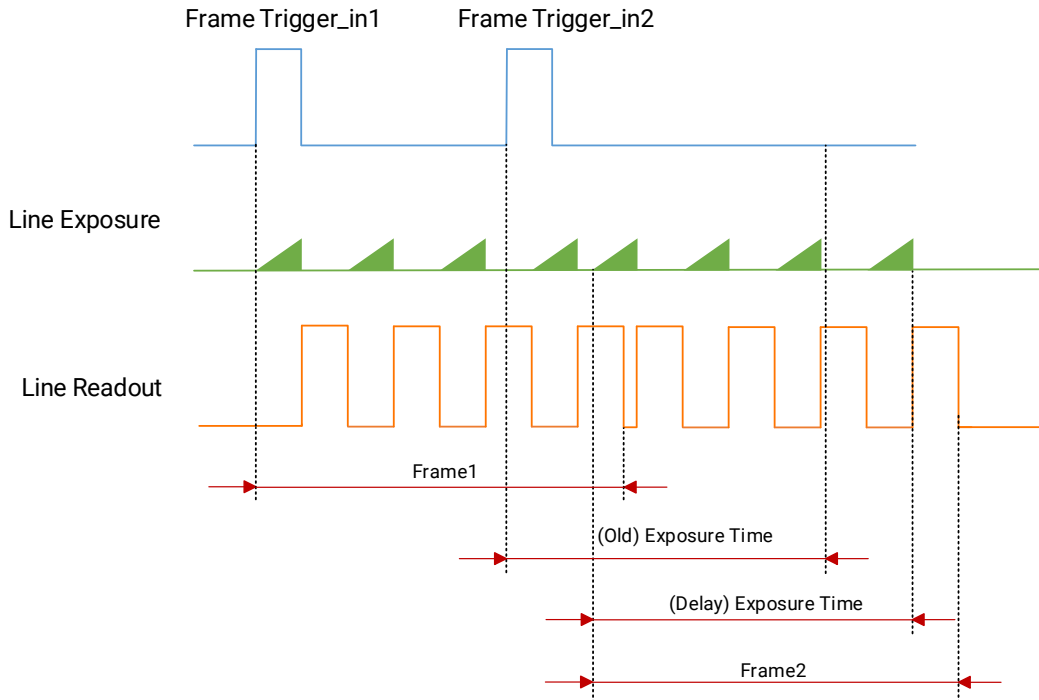

Figure 9-20 Sequence Diagram

Note

The three sequence diagrams above use rising edge as trigger activation, and the device's height parameter is 4.

Set Trigger Cache in Line Trigger

Go to **Acquisition and Transfer Control** → **Line Trigger Control**, and enable **LineTrigger Cache Enable**.

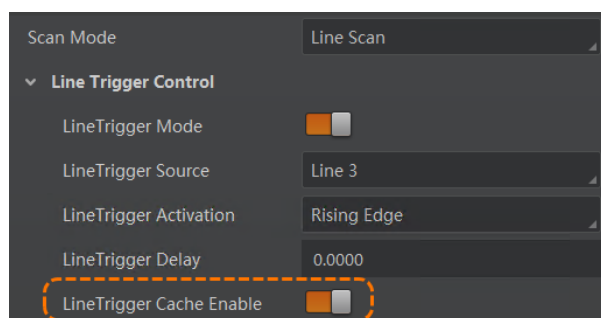

Figure 9-21 Set Trigger Cache in Line Trigger

Set Trigger Debouncer

The trigger debouncer function allows the device to filter out unwanted short external trigger signal that is input to the device.

Go to **I/O Control** → **Line Debouncer Time**, and enter **Line Debouncer Time** according to actual demands. The range of **Line Debouncer Time** is from 0 μ s to 1000000 μ s, and the step is 100 ns.

Note

If the **Line Debouncer Time** you set is greater than the time of trigger signal, this trigger signal will be ignored.

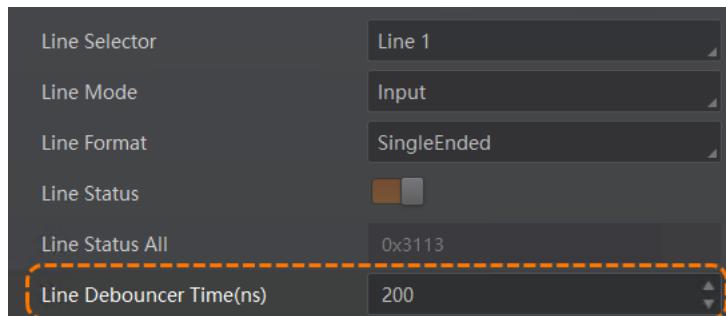

Figure 9-22 Set Trigger Debouncer

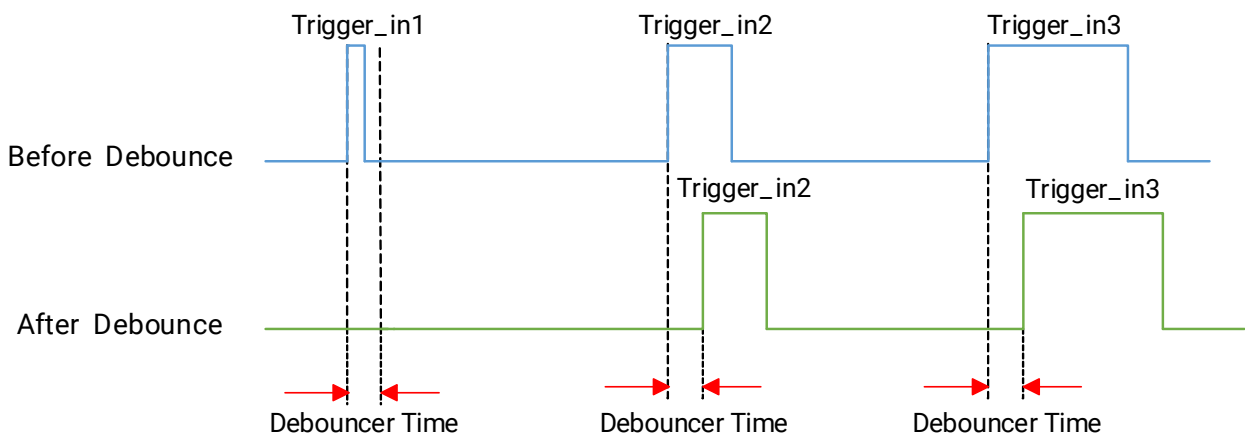

Figure 9-23 Sequence Diagram of Trigger Debouncer

Note

The sequence diagram above uses rising edge as trigger activation.

Set Trigger Delay

The trigger delay function allows the device to add a delay between the receipt of trigger signal and the moment the trigger becomes active.

Go to **Acquisition and Transfer Control** → **Frame Trigger Control**, and enable **Line Delay Enable** and set **FrameTrigger Delay**.

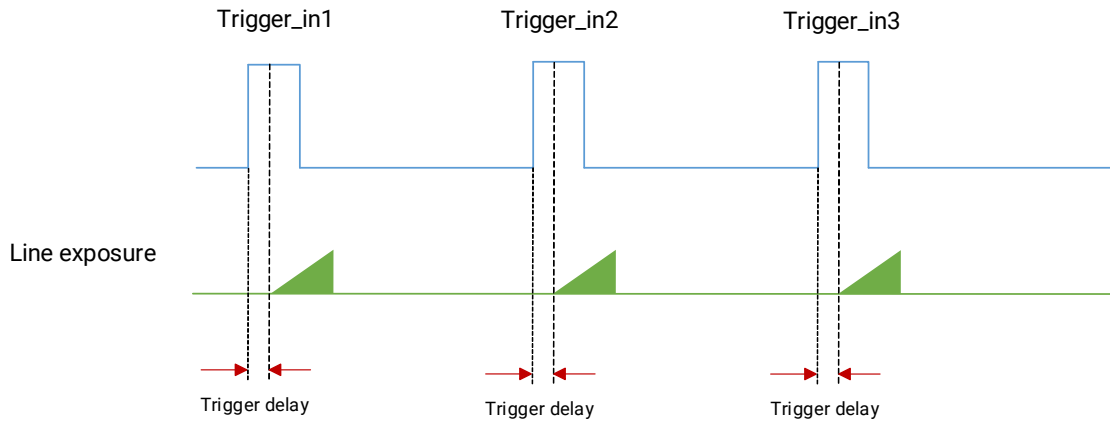

Figure 9-24 Sequence Diagram of Trigger Delay

Note

- The sequence diagram above uses rising edge as trigger activation.
- When **Line Delay Enable** is enabled, set the number of trigger lines for delay in the **FrameTrigger Delay**, or when the **Line Delay Enable** is disabled, set the trigger time for delay in the **Trigger Delay**.
- The **Line Delay Enable** is valid only when the line trigger mode is enabled.

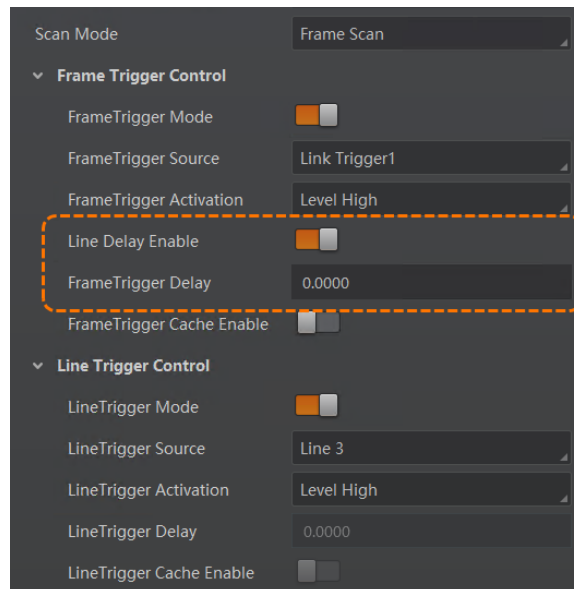

Figure 9-25 Set Trigger Delay

9.2 Trigger Output

The device has multiple bi-directional configurable lines. The method of setting bi-directional configurable line as output line as follows:

Steps

1. Go to **I/O Control**, and select specific line as **Line Selector**.
2. Set **Strobe** as **Line Mode**.
3. Set **Line Format** according to actual demands.

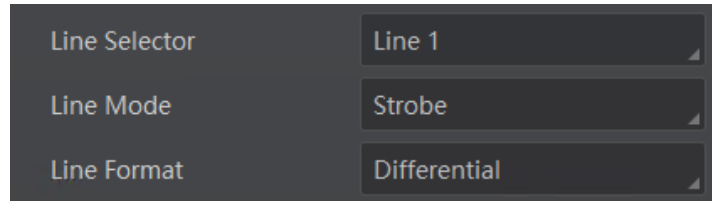

Figure 9-26 Select Output Signal

Note

- Differential stands for the differential signal.
- If a bi-directional configurable line signal is selected as **Line Selector** and **Line Mode** is **Input** currently, but you cannot set **Strobe** as **Line Mode**. The reason is that the bi-directional configurable line signal is selected as trigger source in one of line trigger/frame trigger/shaft encoder control/ frequency converter control settings. You should set other line signals as trigger source in line trigger/frame trigger/shaft encoder control/ frequency converter control settings all.

The output signal of the device is switch signal that can be used to control external devices such as light source, PLC, etc. There are two ways to set output signal, including line inverter and strobe signal.

9.2.1 Enable Line Inverter

The line inverter function allows the device to invert the electrical signal level of an I/O line. Go to **I/O Control** → **Line Inverter**, and enable it.

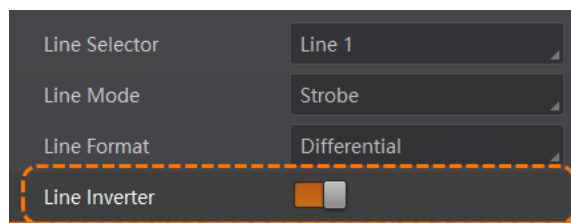

Figure 9-27 Enable Line Inverter

Note

The line inverter function is disabled by default.

9.2.2 Enable Strobe Signal

The strobe signal is used to directly output I/O signal to external devices when the device's event source occurs.

If you need to let the device output signals when it outputs one frame image, follow steps below to set it.

Steps

1. Click **I/O Control**, and set **Exposure Start Active** as **Line Source**.
2. Select **Frame Mode** as **Strobe Source Selector**.
3. Enable **Strobe Enable**.

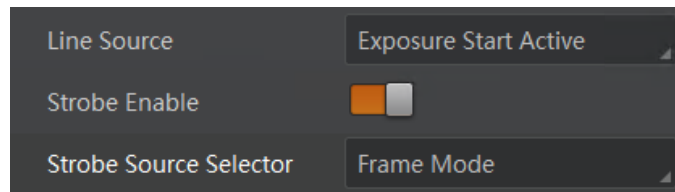

Figure 9-28 Select Frame Mode as Strobe Source Selector

Note

When the **Scan Mode** is **Frame Scan**, the **Frame Mode** can be selected as **Strobe Source Selector**.

If you need to let the device output signals when event sources occur that are corresponding to each line image, follow steps below to set it.

Steps

1. Click **I/O Control**, and select **Line Mode** as **Strobe Source Selector**.
2. Set **Line Source** according to actual demands.
3. Enable **Strobe Enable**.

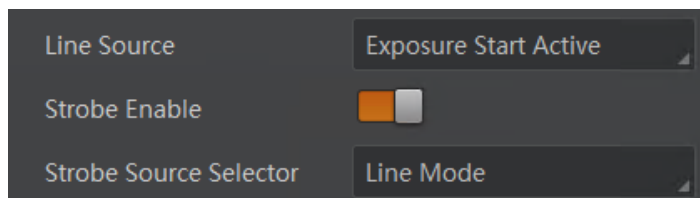

Figure 9-29 Select Line Mode as Strobe Source Selector

After selecting a specific line source, an event information will be generated, and the device will output a Strobe signal at the same time. The supported line sources are as follows:

 **Note**

The specific line sources may differ by device models.

Table 9-6 Line Source Description

Line Source	Description
Exposure Start Active	The device outputs signals to external devices when it starts exposure.
Frame Burst Start Active	The device outputs signals to external devices when the device's frame burst starts.
Frame Burst End Active	The device outputs signals to external devices when the device's frame burst stops.
Soft Trigger Active	The device outputs signals to external devices when it has a software trigger.
Hard Trigger Active	The device outputs signals to external devices when it has a hardware trigger.
Counter Active	The device outputs signals to external devices when it has a counter trigger.
Timer Active	The device outputs signals to external devices when it has a timer trigger.
Frame Start Active	The device outputs signals to external devices when it starts doing the capture of a frame.
Frame End Active	The device outputs signals to external devices when it stops doing the capture of a frame.

When you select **Hard Trigger Active** as the **Line Source**, you should set **Hardware Trigger Source** and **Hardware Trigger Activation**.

- **Hardware Trigger Source:** Select **Line*** in **Hardware Trigger Source**. It is available only when **Line*** is set as **Input**.
- **Hardware Trigger Activation:** Select **Rising Edge** or **Falling Edge**. The device will receive the signal and start to acquire images when **Rising Edge**, **Falling Edge** or **Any Edge** is selected.

When **Counter Active** is selected as **Line Source**, you can go to **Counter and Timer Control** and set specific parameters according to actual demands.

Table 9-7 Description of Counter and Timer Control

Parameter	Read/Write	Description
Counter Selector	Read and write	It selects counter source. Counter 0 is available only at present.
Counter Event Source	Read and write	It selects the signal source of counter trigger, and Off, Line * or Link Trigger * is available. It is disabled by default. It is available only when Line* is set as Input .
Counter Event Activation	Read and write	It selects the activation mode of the selected counter event source, including rising edge, falling edge, and any edge.
Counter Reset Source	Read and write	It selects the signal source of resetting counter. Software is available only. It is disabled by default.
Counter Reset	Write is available under certain condition	It resets counter and it can be executed when selecting Software as Counter Reset Source .
Counter Value	Read and write	It is the counter value with the range of 1 to 4294967295. Note The specific range of counter value may differ by device models.
Counter Current Value	Read only	It displays the number of executed external trigger.

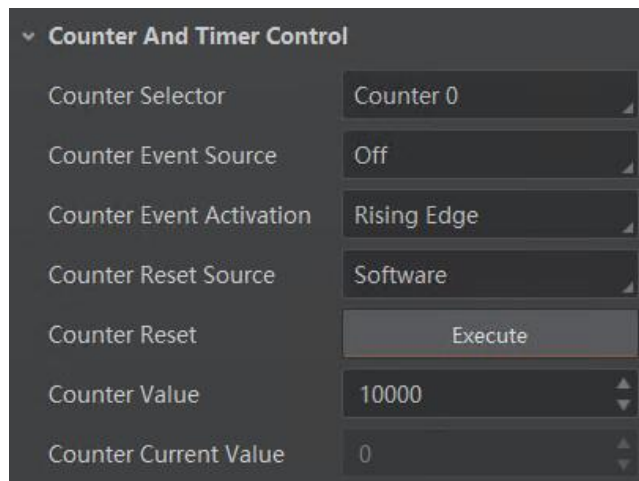

Figure 9-30 Counter and Timer Control

If **Timer Active** is selected as **Line Source**, you can set **Strobe Line Duration** and **Strobe Line Delay**, and the device will output signal correspondingly after click **Execute** in **Line Trigger Software**.

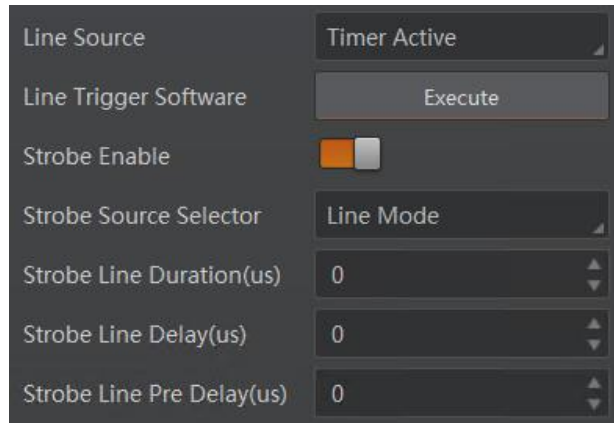

Figure 9-31 Timer Active Parameter

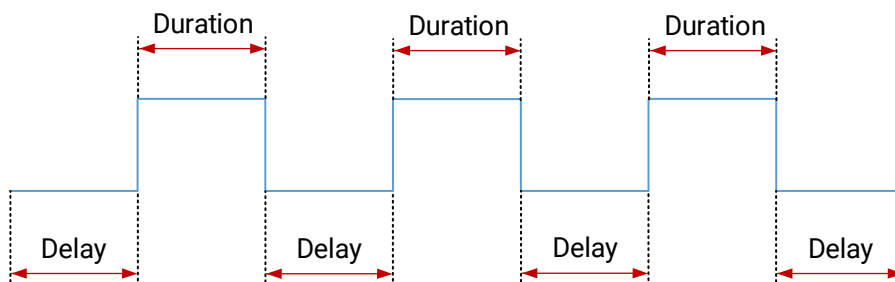

Figure 9-32 Sequence Diagram of Timer Active

Set Strobe Line Duration

After enabling strobe signal, you can set its duration. The unit is μs . Go to **I/O Control** → **Strobe Line Duration**, and enter it according to actual demands.

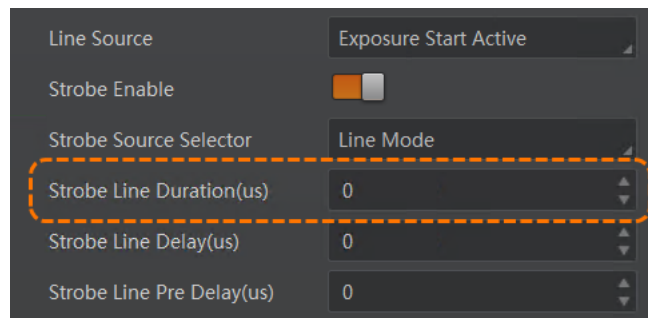

Figure 9-33 Set Strobe Line Duration

Note

- When the **Strobe Line Duration** value is 0, the strobe duration is equal to the exposure time.
- When the **Strobe Line Duration** value is not 0, the strobe duration is equal to **Strobe Line Duration** value.

Set Strobe Line Delay

The device supports setting strobe line delay to meet actual demands. When exposure starts, the strobe output does not take effect immediately. Instead, the strobe output will delay according to the strobe line delay setting.

Go to **I/O Control** → **Strobe Line Delay**, and enter **Strobe Line Delay** according to actual demands. The sequence diagram of strobe line delay is shown below.

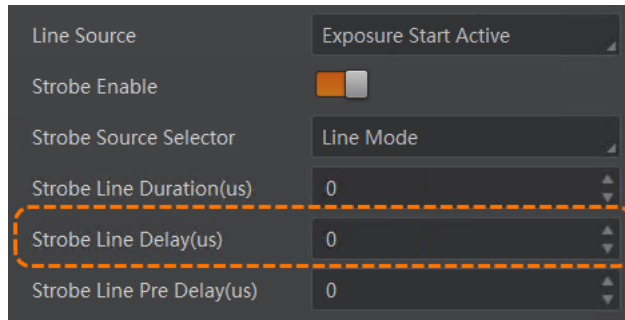

Figure 9-34 Set Strobe Line Delay

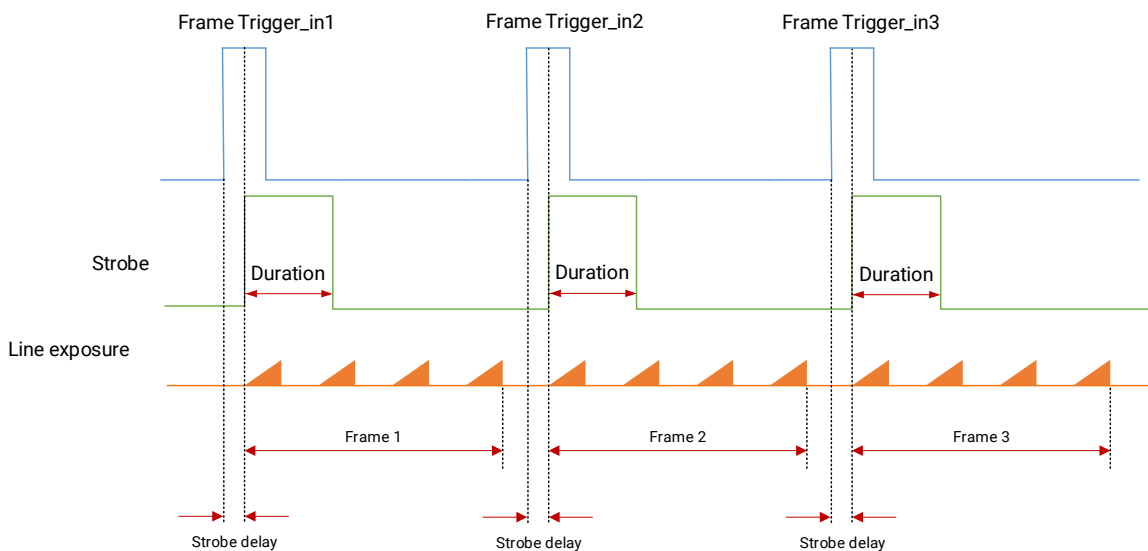

Figure 9-35 Sequence Diagram of Strobe Line Delay

Note

- The device's height parameter is 4 in the sequence diagram above.
- The range of the strobe line delay is from 0 to 10000, and the unit is μs .

Set Strobe Line Pre Delay

The device also supports the function of strobe line pre delay, which means that the strobe signal takes effect early than exposure. This function is applied to the external devices that have slow response speed.

Go to **I/O Control** → **Strobe Line Pre Delay**, and enter **Strobe Line Pre Delay** according to actual demands. The sequence diagram of strobe line pre delay is shown below.

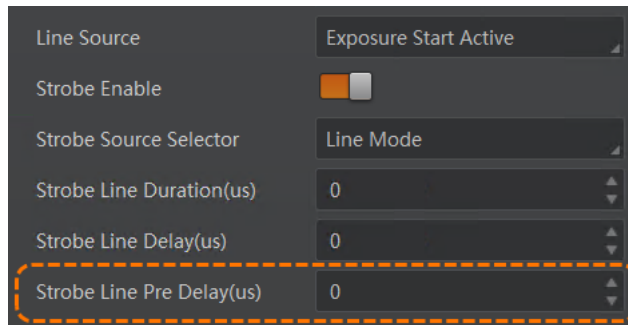

Figure 9-36 Set Strobe Line Pre Delay

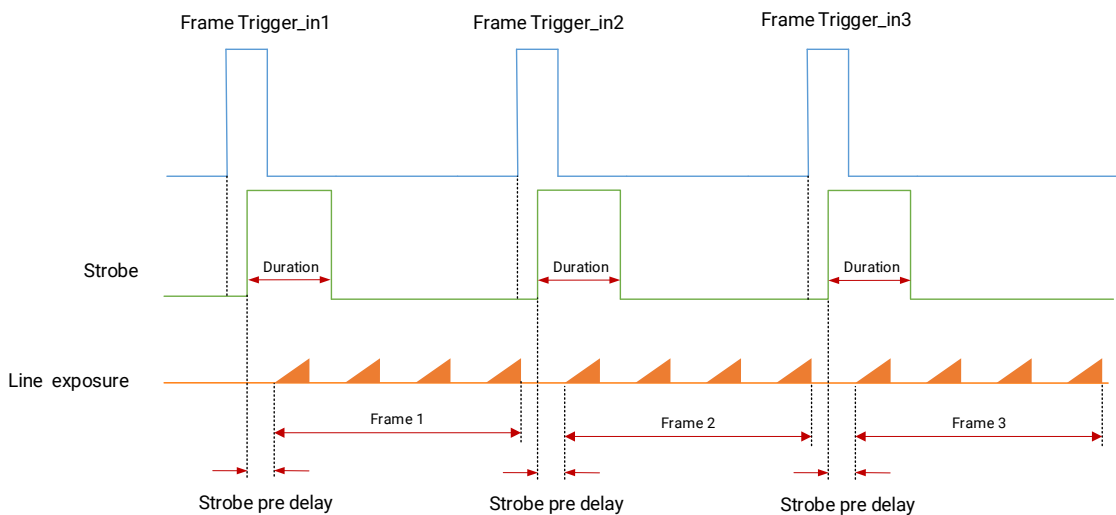

Figure 9-37 Sequence Diagram of Strobe Line Pre Delay

Note

- The device's height parameter is 4 in the sequence diagram above.
- The range of the strobe line delay is from 0 to 10, and the unit is μs .

Chapter 10 Image Acquisition

10.1 Set Line Rate

10.1.1 Line Rate Overview

Line rate refers to the number of image lines that is output by the device per second. The frame rate of the device is proportional to its line rate, and is inversely proportional to the image height, that is, $Fps = Lps \text{ (line rate)} / \text{Height (image height)}$.

The following factors determine the device's line rate in real time.

- Readout time: The less the readout time and the higher the line rate will be.
- Exposure time: The less the exposure time, the higher the line rate will be.
- Pixel format: The more bytes pixel format occupy, the lower the line rate will be.
- Link quantity: The more CoaXPress cables are used, the larger transmitted data and the higher the line rate will be.

Steps

1. Go to **Acquisition and Transfer Control** → **Acquisition Line Rate(Hz)**, and enter the value.
2. Enable **Acquisition Line Rate Control Enable**.

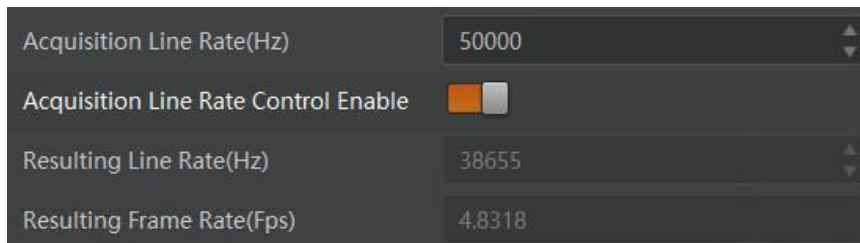

Figure 10-1 Set Line Rate

Note

- If the real-time line rate is smaller than the value you set, the device acquires images by the real-time line rate.
- If the real-time line rate is larger than the value you set, the device acquires images by the value you set.

10.1.2 Adjust Line Rate

Image compression and image stretching may occur when the captured line rate does not match with the moving speed of the target object.

- **Normal:** Captured line rate = moving speed of the target object
- **Image stretching:** Captured line rate > moving speed of the target object
- **Image compression:** Captured line rate < moving speed of the target object

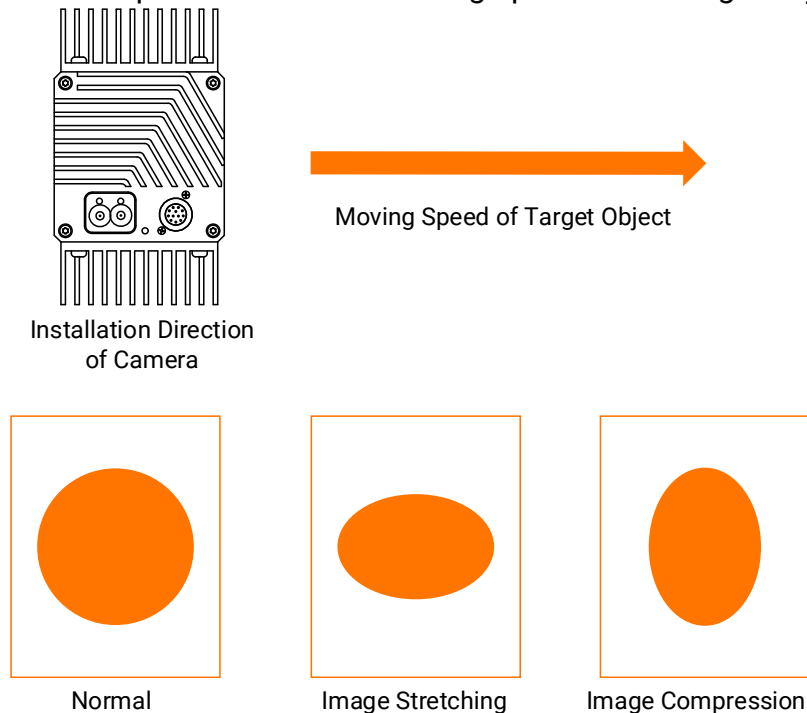

Figure 10-2 Adjust Line Rate

You can adjust the pixel ratio in both the length and width directions of a circular or square object to 1:1. Image compression or image stretching can be adjusted by increasing and decreasing the line rate, respectively.

The method of adjusting the line rate varies depending on the moving speed of the target object.

- When the target object is moving at a uniform speed, set the **Acquisition Line Rate(Hz)** to the line rate calculated from the object's moving speed.

The calculation formula of line rate is shown below. The Pixel is the lateral resolution of the camera, V is the moving speed of the target object, and L is the lateral length of the object.

$$\text{Hz (Line Rate)} = \frac{\text{Pixel} \times V}{L}$$

- When the target object is moving at a non-uniform speed, you can change to line trigger mode, and adjust the line rate by setting the pre-divider, multiplier and post-divider. Refer to section [Set Trigger Mode](#) and section [Set and Execute Frequency Converter Control](#).

10.2 Set Scan Mode

Note

The scan mode function may differ by device models.

The device supports selecting different methods of reading image data, including frame scan and line scan. Go to **Acquisition and Transfer Control** → **Scan Mode** to select it according to actual demands.

- **Frame Scan**: The device outputs a frame of image after its output line quantity reaches configured image height.
- **Line Scan**: The device outputs one line of image after each exposure.

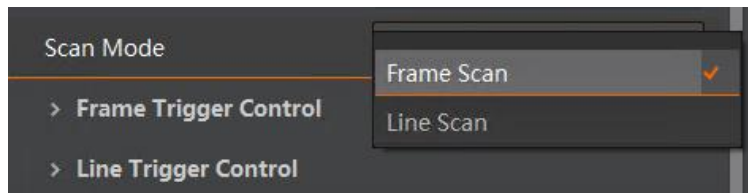

Figure 10-3 Set Scan Mode

Note

- If the **Scan Mode** selects **Line Scan**, the **Line Trigger Control** can be set only.
- The scan mode of the camera should be the same as that of the frame grabber. Refer to *CoaXPress Frame Grabber User Manual* for details.

10.3 Set Scan Direction

Note

- The scan direction function may differ by device models.
- Make sure that the scan direction and the moving direction of objects are matched. Otherwise, acquired images may be abnormal.
- The scan direction can be set only when **2/4-TDI** is selected as **TDI Mode**. Refer to [Set TDI Function](#) for details.

The scan direction function is used to change the scan direction of the sensor used on measured objects. The figures below are the actual effects.

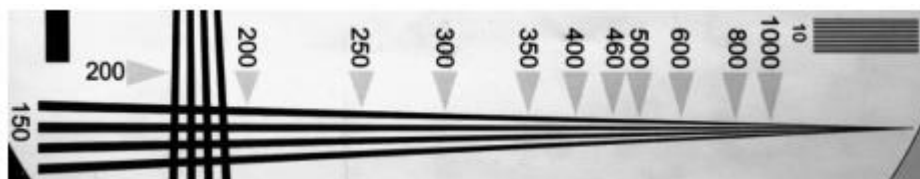

Figure 10-4 Image when Direction Matched of Mono Device

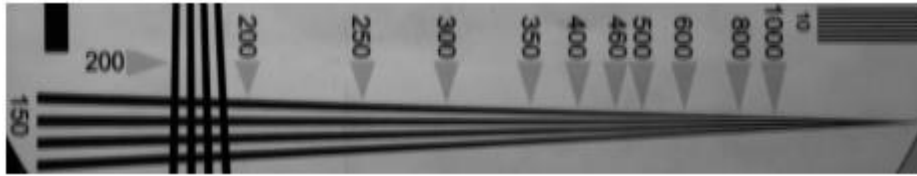

Figure 10-5 Image when Direction Mismatched of Mono Device

Steps

1. Go to **Image Format Control** → **Direction Source**.
2. Set **Internal** as **Direction Source**. The device will change the scan direction via internal signal.
3. Enable **Reverse Scan Direction** according to the moving direction.

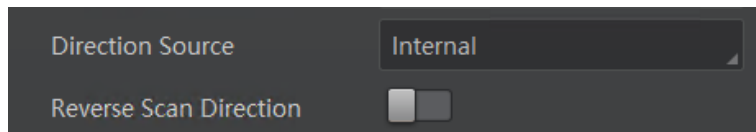

Figure 10-6 Internal Direction Source

10.4 Set Frame Timeout

The device supports frame timeout function that affects the device’s acquisition and image output mechanism.

Go to **Acquisition and Transfer Control**, enable **Frame Timeout Enable**, and select **Partial Image Output Mode** according to actual demands.

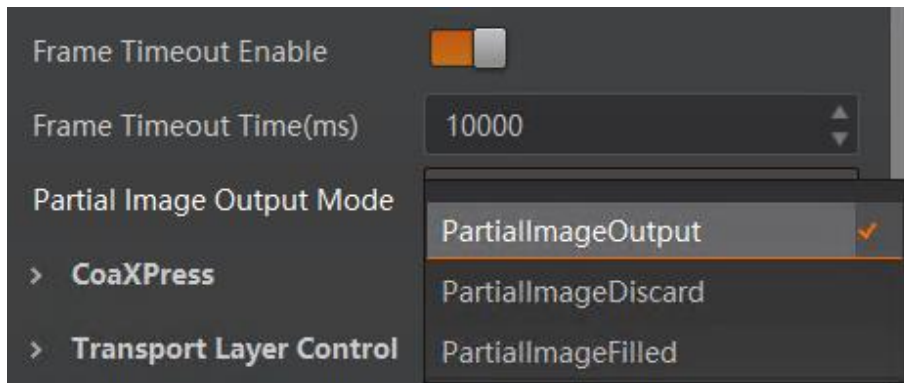

Figure 10-7 Set Frame Timeout

Table 10-1 Partial Image Output Mode Description

Parameter	Description
Image Pending	After the number of lines output by the device reaches the configured image height (height parameter), one frame of the image will be outputted. If the number of output lines does not reach the image height (height parameter), the SDK will not

Parameter	Description
	output the image, and the SDK will wait for the line data until it reaches the image height before outputting the image.
PartialImageOutput	When the number of lines output by the device reaches the configured image height (height parameter) within the frame timeout period, and one frame of image will be output. If the number of lines output by the device does not reach the configured image height (height parameter) within the frame timeout period, the SDK will output the image according to the actual height.
PartialImageDiscard	When the number of lines output by the device reaches the configured image height (height parameter) within the frame timeout period, and one frame of image will be output. If the number of lines output by the device does not reach the configured image height (height parameter) within the frame timeout period, the SDK discards the image.
PartialImageFilled	When the number of lines output by the device reaches the configured image height (height parameter) within the frame timeout period, and one frame of image will be output. If the number of lines output by the device does not reach the configured image height (height parameter) within the frame timeout period, SDK will output the image after filling the black according to the height parameter for the remaining part.

 **Note**

- If **Frame Timeout Enable** is enabled, you can select **PartialImageOutput**, **PartialImageDiscard**, and **PartialImageFilled**.
- If **Frame Timeout Enable** is not enabled, the image output is related with configured trigger mode.
 - When the **FrameTrigger Mode** and **LineTrigger Mode** are **Off**, or when **LineTrigger Mode** is **On**, only **Image Pending** is supported.
 - When the **FrameTrigger Mode** and **LineTrigger Mode** are **On**, and **FrameTrigger Activation** and **LineTrigger Activation** are **Level High** or **Level Low**, or when **FrameTrigger Mode** is **On**, and **FrameTrigger Activation** is **Level High** or **Level Low**, all image output modes are supported, and the device outputs last frame of image in accordance with configured image output mode.
- The **Frame Trigger Control** can be set only if the **Frame Scan** is selected as **Scan Mode**.

10.5 Set Line Discard Function

Note

- The line discard function may differ by device models.
 - The line discard function can be set only when **2/4-TDI** is selected as **TDI Mode**. Refer to section [Set TDI Function](#) for details.
-

Due to the inherent functional features of the sensor or the device itself, the first few lines of image acquisition may have abnormal images and need to be discarded. The device provides line discard function, which can adjust and control the number of external line trigger signals to ensure that the image acquisition meets the usage requirements. You can go to **Image Format Control**, and enable **Abnormal Line Enable** according to actual demands.

- When this function is enabled, the external device needs to send N more trigger signals to meet the line height of image acquisition, and the first N lines of abnormal images are discarded.
 - When this function is not enabled, the quantity of external trigger signal is equal to that of the device's line height, and any abnormal lines that may exist are not discarded.
-

Note

The lines of abnormal images that are discarded is determined by internal logic of the camera.

Chapter 11 Image Parameter

11.1 Set Resolution and ROI

Note

The device displays the image with max. resolution by default.

Go to **Image Format Control**, and you can view resolution by reading **Width Max** and **Height Max**.

Width Max stands for the max. pixels per inch in width direction, and **Height Max** stands for the max. pixels per inch in height direction.

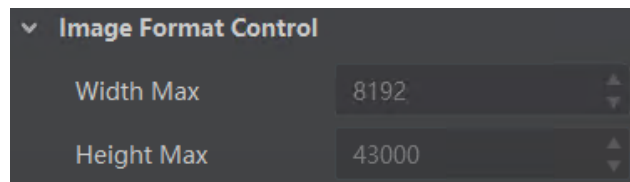

Figure 11-1 View Resolution

If you are only interested in a certain region of the image, you can set a Region of Interest (ROI) for the device.

Note

- The device supports one ROI only, and you can select **Region 0** as **Region Selector**.
 - Region of interest can be set only when you stop real-time acquisition.
-

Go to **Image Format Control** → **Region Selector**, and enter **Width**, **Height**, and **Offset X**.

Note

- The **Width** plus **Offset X** should not be larger than **Width Max**, and **Height** should not be larger than **Height Max**.
 - The step size of the **Width**, **Height**, and **Offset X** may vary. Please refer to the actual one.
 - **Width**: It stands for horizontal resolution in ROI area.
 - **Height**: It stands for vertical resolution in ROI area.
 - **Offset X**: It refers to the horizontal coordinate of the upper left corner of the ROI.
-

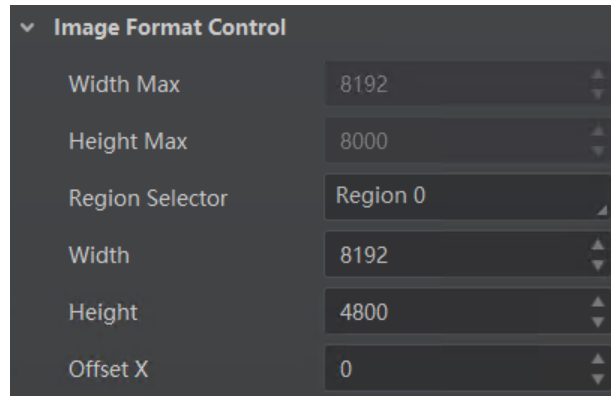

Figure 11-2 Set ROI

11.2 Set Image Reverse

The device supports reversing images in a horizontal way. Go to **Image Format Control**, and enable **Reverse X** according to actual demands.

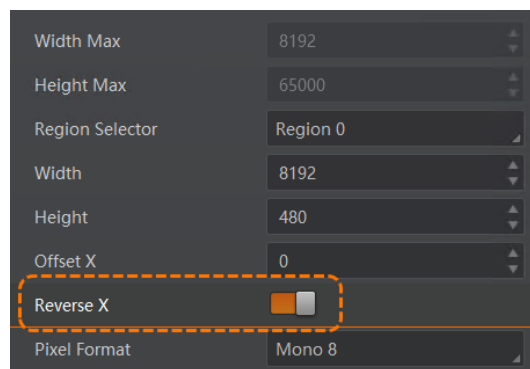

Figure 11-3 Set Image Reverse

11.3 Set Pixel Format

This function allows you to set the pixel format of the image data transmitted by the device. Go to **Image Format Control** → **Pixel Format**, and set **Pixel Format** according to actual demands.

Note

The specific pixel formats may differ by device models.

Table 11-1 Pixel Format and Pixel Size

Pixel Format	Pixel Size (Bits/Pixel)
Mono 8	8

Pixel Format	Pixel Size (Bits/Pixel)
Mono 10	10
Mono 12	12



Figure 11-4 Set Pixel Format

11.4 Set Test Pattern

Note

The test pattern may differ by device models.

The device supports test pattern function. When there is exception in real-time image, you can check whether image of test mode have similar problem to determine the reason. This function is disabled by default, and at this point, the output image by the device is real-time image. If this function is enabled, the output image by the device is test image.

Go to **Image Format Control** → **Test Pattern**, and set **Test Pattern** according to actual demands.

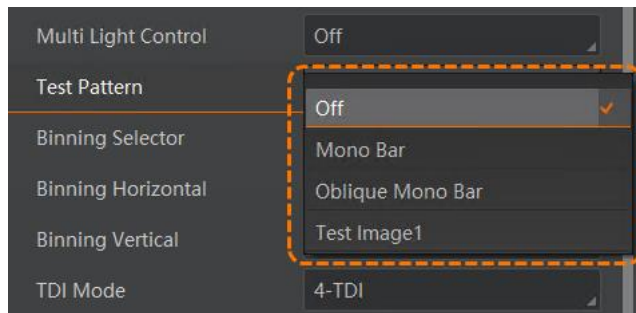

Figure 11-5 Set Test Pattern

The mono device offers 3 test patterns, including **Mono Bar**, **Oblique Mono Bar**, and **Test Image 1**.



Figure 11-6 Mono Bar Test Pattern

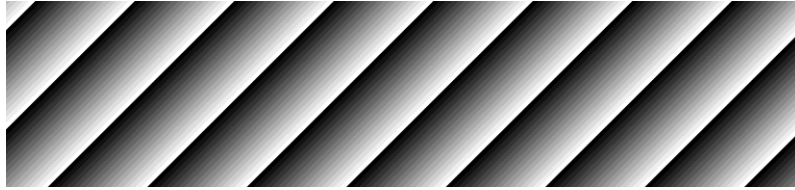

Figure 11-7 Oblique Mono Bar Test Pattern



Figure 11-8 Test Image 1

Note

The pattern of the test image 1 may differ by device models.

11.5 Set Binning

The purpose of setting binning is to enhance sensibility. With binning, multiple sensor pixels are combined as a single pixel to reduce resolution and improve image brightness. Click **Binning Selector**, and set **Binning Horizontal** and **Binning Vertical** according to actual demands.

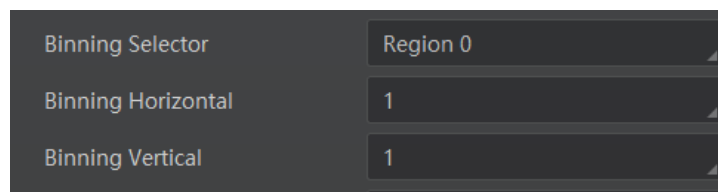

Figure 11-9 Set Binning

Note

- **Binning Horizontal** is the image's width, and **Binning Vertical** is the image's height.
 - The binning function may differ by device models.
-

11.6 Set Exposure Mode

The exposure mode supports **Timed** and **Trigger Width**. When selecting **Timed**, you can set **Exposure Auto** and **Exposure Time**. When you select **Trigger Width**, the exposure time and level signal time are the same, and **Exposure Auto** and **Exposure Time** are invalid.

Note

The **Trigger Width** can be selected as the **Exposure Mode** when the requirements below

are met:

- **LineTrigger Mode** in **Line Trigger Control** is enabled.
 - **Line *** is selected as the **LineTrigger Source**.
 - **Level High** or **Level Low** is selected as **LineTrigger Activation**.
-

The **Exposure Auto** supports 3 types, including **Off**, **Once** and **Continuous**. Go to **Acquisition and Transfer Control** → **Exposure Auto**, and select **Exposure Auto** according to actual demands.

- **Off**: The device exposures according to the value set in **Exposure Time (μs)**.
- **Once**: The device adjusts the exposure time automatically according to the image brightness. After adjusting, it will switch to **Off** mode.
- **Continuous**: The device adjusts the exposure time continuously according to the image brightness.

When the exposure mode is set as **Once** or **Continuous**, the exposure time should be within the range of **Auto Exposure Time Lower Limit (μs)** and **Auto Exposure Time Upper Limit (μs)**.

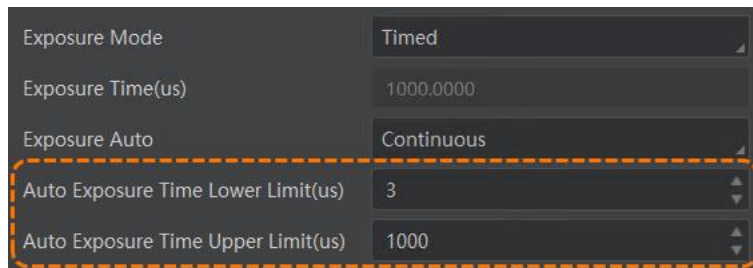

Figure 11-10 Set Exposure Time under Once or Continuous Mode

Note

The exposure auto function may differ by device models.

11.7 Set Brightness

The device brightness refers to the brightness when the device adjusts image under **Once** or **Continuous** exposure mode.

Note

- You should enable **Once** or **Continuous** exposure mode first before setting brightness.
 - After setting brightness, the device will automatically adjust exposure time to let image brightness reach target one. Under **Once** or **Continuous** exposure mode, the higher the brightness value, the brighter the image will be.
 - The range of brightness is between 0 and 255.
-

Table 11-2 Brightness Example

Brightness Value	Image
Brightness=25	
Brightness=75	
Brightness=120	

Go to **Advanced Processing** → **Brightness**, and enter **Brightness** according to actual demand.

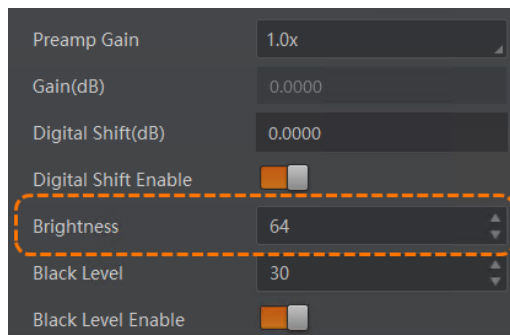

Figure 11-11 Set Brightness

11.8 Set Black Level

Note

The black level may differ by device models.

The device supports black level function that allows you to change the overall brightness of an image by changing the gray values of the pixels by a specified amount.

Go to **Advanced Processing** → **Black Level Enable**, enable **Black Level Enable**, and enter **Black Level** according to actual demands.

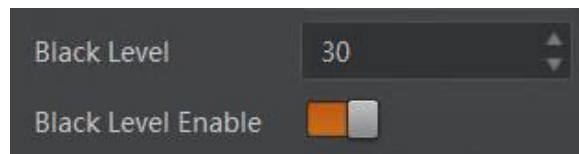

Figure 11-12 Set Black Level

11.9 Set Gamma Correction

Note

The Gamma correction function may differ by device models.

The device supports Gamma correction function. Generally, the output of the device's sensor is linear with the photons that are illuminated on the photosensitive surface of the sensor. Gamma correction provides a non-linear mapping mechanism as shown below.

- Gamma value between 0.5 and 1: image brightness increases, dark area becomes brighter.
- Gamma value between 1 and 4: image brightness decreases, dark area becomes darker.

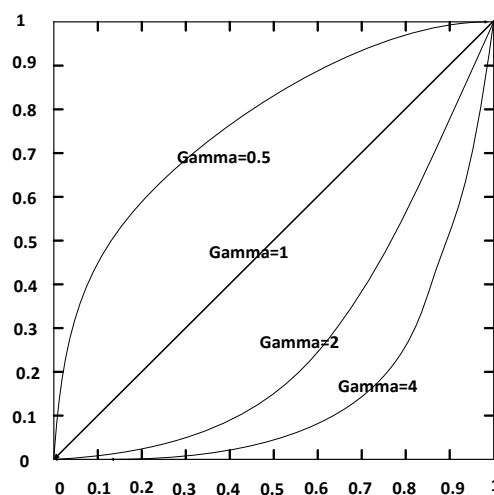

Figure 11-13 Set Gamma Correction

Table 11-3 Gamma Correction Example

Gamma Value	Image
Gamma=0.5	
Gamma=1.5	
Gamma=2	

There are 2 types of Gamma correction, including **User** mode and **sRGB** mode. Settings method is different as shown below.

User Mode

Steps

1. Go to **Advanced Processing** → **Gamma Selector**.
2. Select **User** as **Gamma Selector**.
3. Enable **Gamma Enable** to enable it.
4. Enter **Gamma** according to actual demands, and its range is from 0 to 4.

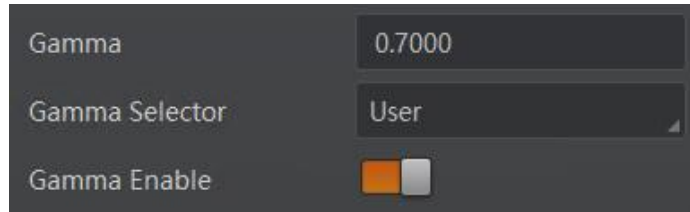

Figure 11-14 Set User Mode

sRGB Mode

Steps

1. Go to **Advanced Processing** → **Gamma Selector**.
2. Select **sRGB** as **Gamma Selector**.
3. Enable **Gamma Enable** to enable it.

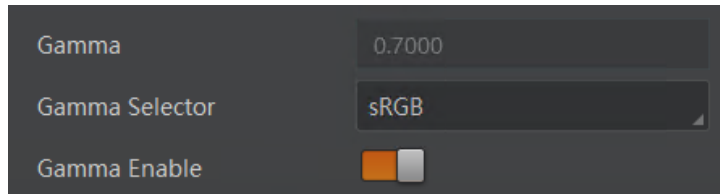

Figure 11-15 Set sRGB Mode

11.10 Set Gain

The device has 2 types of gain, including the analog gain and digital gain. The analog gain is applied before the signal from the device sensor is converted into digital values, while digital gain is applied after the conversion.

When increasing gain, the image noise will increase too, which will influence image quality. If you want to increase image brightness, it is recommended to increase the device's exposure time first. If the exposure time reaches its upper limit, and at this point, you can increase gain. It is recommended to use analog gain first, and then to adjust digital gain if the analog gain cannot meet demands.

11.10.1 Set Analog Gain

Go to **Advanced Processing** → **Preamp Gain**, and set **Preamp Gain** according to actual demands.

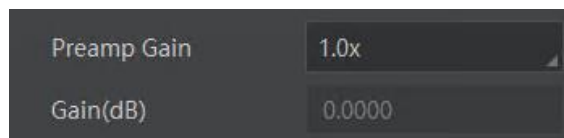

Figure 11-16 Set Analog Gain

11.10.2 Set Digital Gain

Apart from analog gain, the device supports digital gain function. When analog gain reaching its upper limit and the image is still too dark, it is recommended to improve image brightness via digital gain.

Click **Advanced Processing**, enable **Digital Shift Enable**, and enter **Digital Shift** according to actual demands.

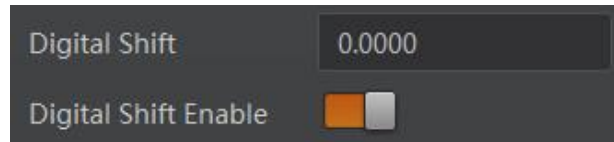

Figure 11-17 Set Digital Gain

Note

The digital gain function is disabled by default, and its value range is from -24.082399 to 23.999836 .

11.11 Set Sharpness

Note

The sharpness function may differ by device models, and is disabled by default.

The device supports sharpness function that can adjust the sharpness level of the image edge. You can set sharpness as shown below.

Go to **Advanced Processing** → **Sharpness Enable**, enable **Sharpness Enable**, and enter **Sharpness** according to actual demands.

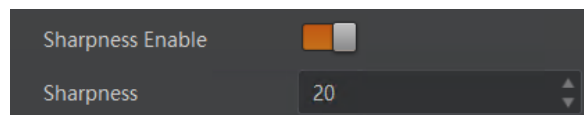

Figure 11-18 Set Sharpness

11.12 Set Digital Noise Reduction

Note

The function of digital noise reduction may differ by device models.

The function of digital noise reduction can increase the image's SNR and improve its quality.

Steps

1. Go to **Advanced Processing** → **Digital Noise Reduction Mode**.
2. Select **Expert** as **Digital Noise Reduction Mode**. **Off** means that this function is disabled.
3. Enter **Denoise Strength** and **Noise Correct** according to actual demands.
 - **Denoise Strength** refers to the noise reduction intensity, and you can increase it to have a better effect.
 - **Noise Correct** refers to the noise correction value, and it is used to adjust the standard deviation of the noise curve to match the real image, enhancing the ability to distinguish between noise and image texture. You can set this value according to the real scenarios.

11.13 Set AOI

Note

- The AOI function may differ by device models.
 - AOI 1 is used when the device is in once or continuous exposure mode.
-

The device supports AOI function that can adjust the brightness of the entire image based on the area you selected.

Steps

1. Click **Advanced Processing** → **AutoFunctionAOI Control** → **Auto Function AOI Selector**, and select **AOI 1**.
2. Enter **Auto Function AOI Width**, **Auto Function AOI Height**, **Auto Function AOI Offset X**, and **Auto Function AOI Offset Y** according to actual demands.
3. Enable **Auto Function AOI Usage Intensity**.

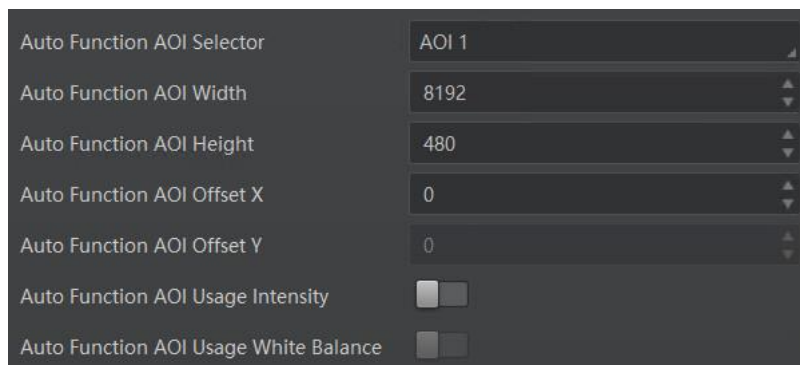

Figure 11-19 Set AOI

11.14 Set Sensor Mode

Note

- The sensor mode function may differ by device models.
 - The sensor mode can be set only when **2/4-TDI** is selected as **TDI Mode**. Refer to [Set TDI Function](#) for details.
-

The device provides two types of sensor mode, including high full well mode and high sensitivity.

- **High Full Well Mode:** It greatly improves SNR.
- **High Sensitivity:** It improves the overall brightness of images and is applicable to low-light environment.

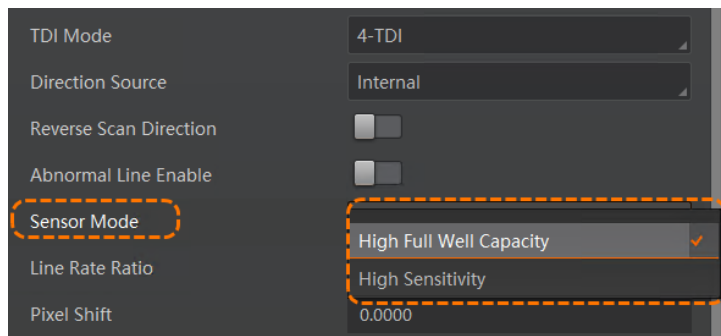

Figure 11-20 Set Sensor Mode

11.15 Set Sequence

If the device supports sequencer, you can configure multiple groups of parameters including exposure time and digital gain. The principle of the sequencer is shown below.

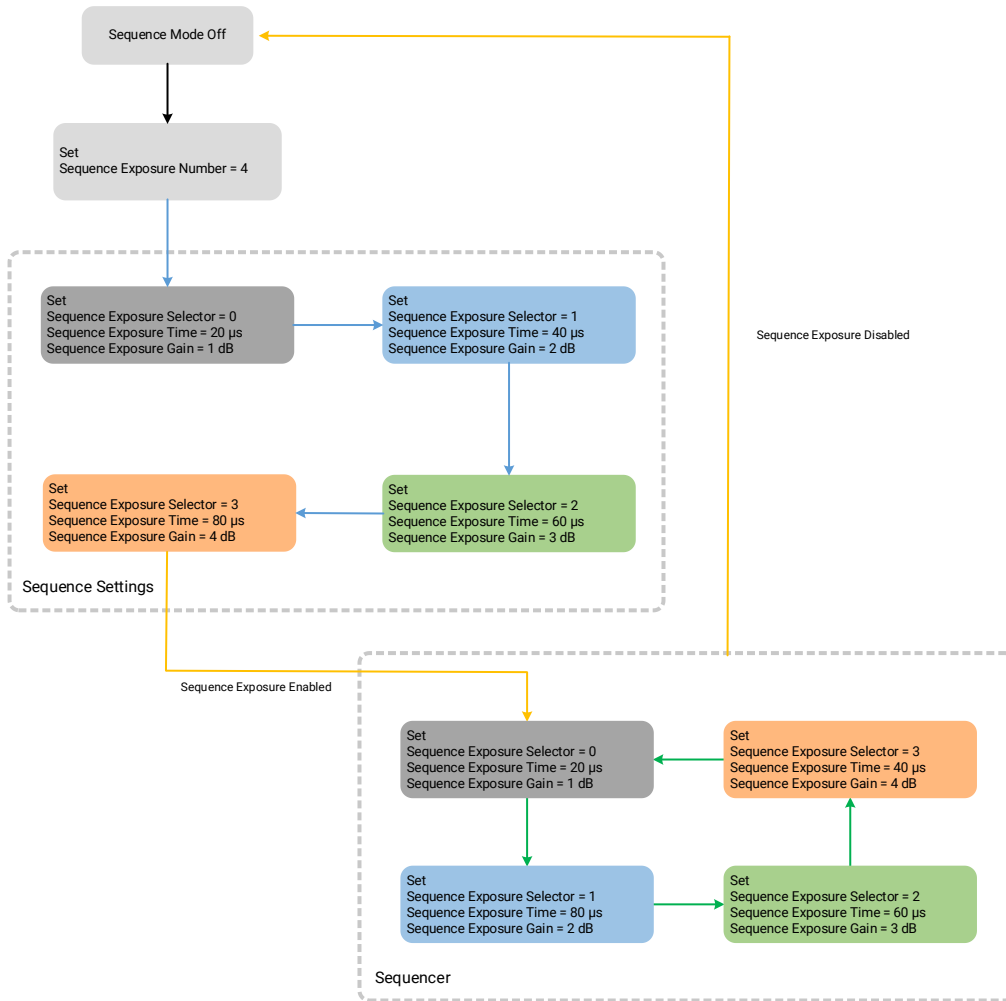

Figure 11-21 Principle of Sequencer

Steps

1. Go to **Image Format Control**, and set **Sequence Exposure Number** to configure how many groups to join sequencer according to actual demands.

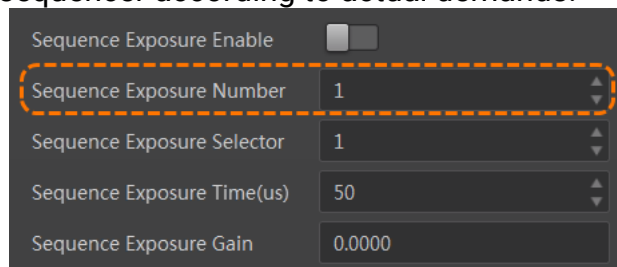

Figure 11-22 Set Sequence Exposure Number

2. Set **Sequence Exposure Selector** to select one group of parameters.
3. Set the exposure time and digital gain of the selected parameter in **Sequence Exposure Time** and **Sequence Exposure Gain**.

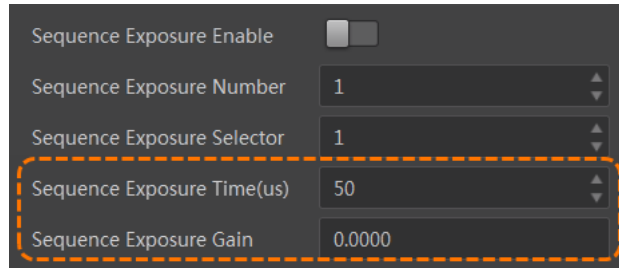

Figure 11-23 Set Sequence Exposure Time and Gain

4. Repeat step 2 to step 3 to configure other group of parameters.
5. Enable **Sequence Exposure Enable** to start sequencer after configuration.

Note

When the sequence mode function is enabled, the device will automatically adjust the related parameters. Please refer to the actual one you got.

11.16 Set TDI Function

Note

The TDI function may differ by device models.

TDI refers to Time Delay Integration, and it is a method of line scanning which provides dramatically increased responsivity compared to other video scanning methods. It permits much greater scanning speeds in low light, or allows reduced lighting levels (and costs) at conventional speeds. In general, there are 3 TDI modes, including 1 line, 2-TDI, and 4-TDI.

- 1 line refers to single line mode, and the device selects 1 line data as output result.
- 2-TDI means that the device overlaps 2 adjacent line data, and outputs 1 line data as final result.
- 4-TDI means that the device overlaps 4 adjacent line data, and outputs 1 line data as final result.

Go to **Image Format Control** → **TDI Mode**, and set **TDI Mode** according to actual demands.

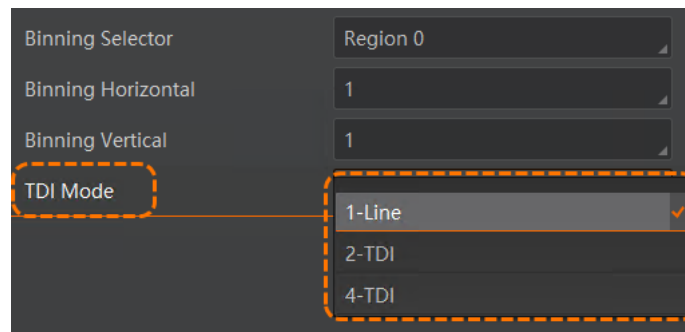

Figure 11-24 Set TDI Mode

11.17 Set Multiple Lights Control

Some devices support function of multiple lights control, which the device can control up to four lights installed at different angles to light up in accordance with configured strobe logic. Then the device can get multiple images of the same target illuminated from different angles.

Note

Settings for level inverter and strobe signal will be invalid when the function of multiple lights control is enabled.

Click **Image Format Control** → **Multi Light Control**, and select **Multi Light Control** according to actual demands.

- **Off**: The function of multiple lights control is disabled if **Off** is selected as **Multi Light Control**. At this time, the device does not output the light source synchronized control signal.
- **1 Light**: Light 1 is turned on if **1 Light** is selected as **Multi Light Control**.
- **2 Lights**: Light 1 and light 2 are turned on if **2 Lights** is selected as **Multi Light Control**.
- **3 Lights**: Light 1, light 2 and light 3 are turned on if **3 Lights** is selected as **Multi Light Control**.
- **4 Lights**: Light 1, light 2, light 3 and light 4 are turned on if **4 Lights** is selected as **Multi Light Control**.
- **MultiExposure**: The function of multiple lights control is disabled and multiple exposure mode is enabled. At this time, the device supports configuring two sets of exposure time and gain, namely, **Multi Exposure0 (us)**, **MultiGain0 (dB)**, **Multi Exposure1 (us)**, and **Multi Gain1 (dB)**.

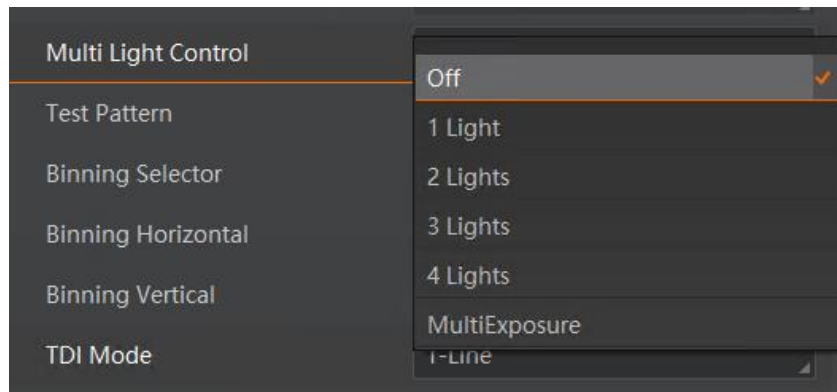

Figure 11-25 Set Multiple Lights Control

Note

- When **TDI Mode** is **1-Line**, **Multi Light Control** supports setting **Off**, **1/2/3/4 Lights**, and **MultiExposure**.
- When **TDI Mode** is **2-TDI**, **Multi Light Control** only supports setting **Off** and **1/2 Lights**.
- When **TDI Mode** is **4-TDI**, **Multi Light Control** only supports setting **Off** and **1 Light**.

The device uses four I/Os (Line 0/1/3/4) to output trigger signals, and light 1 to light 4 are turned on correspondingly. The output pulse diagram of four I/Os is shown below.

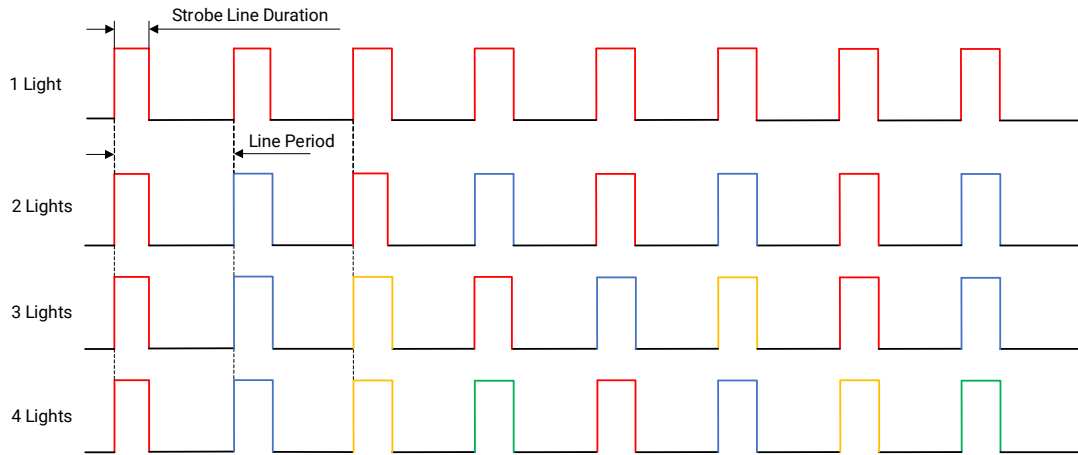

Figure 11-26 Pulse Diagram

Note

- Red, blue, yellow, and green colors represent output pluses by Line 0, Line 1, Line 3, and Line 4 correspondingly.
- You can set **Strobe Line Duration** and **Strobe Line Delay** of **I/O Control** when function of multiple lights control is enabled. The unit of **Strobe Line Duration** and **Strobe Line Delay** is μs .
- The sum of **Strobe Line Duration** and **Strobe Line Delay** should be smaller than or equal to line period time due to the device's limitation. If the sum is larger than line period time, the device will use max. value instead.

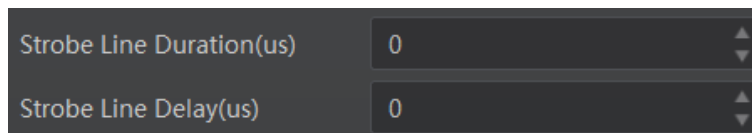

Figure 11-27 Strobe Line Duration and Strobe Line Delay

11.18 Set LUT

A Look-Up Table (LUT) is a customizable grayscale-mapping table. You can stretch and amplify the grayscale range. The mapping can be linear or customized curve.

Note

- You cannot use Gamma correction function and LUT function at the same time.
- The range of the LUT index is from 0 to 1023.
- The range of the LUT value is from 0 to 4095. The value of LUT value is four times the value of LUT index by default.

Steps:

1. Click **LUT Control**, and enable **LUT Enable**.
2. Enter **LUT Index** and **LUT Value** according to actual demands.
3. Click **Execute** in **LUT Save** to save it.

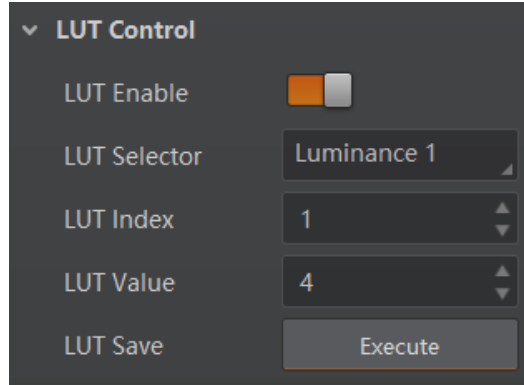

Figure 11-28 Set LUT

11.19 Set Shading Correction

The flat field correction (FFC) includes PRNUC correction and FPNC correction, and they are used to improve the image uniformity that may be impacted by the sensor, light sources, external conditions, etc.

11.19.1 Set FPNC Correction

Steps

1. Click **Shading Correction**, and **User Flat Field Correction** is disabled by default.

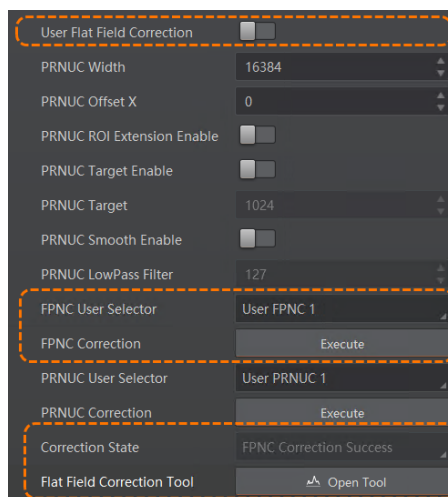

Figure 11-29 Set FPNC Correction

2. Select one **User FPNC** from **FPNC User Selector**.

Note

Up to three groups of User FPNC can be selected.

3. Click **Open Tool** in **Flat Field Correction Tool** and click **Perform FPN Calibration**.

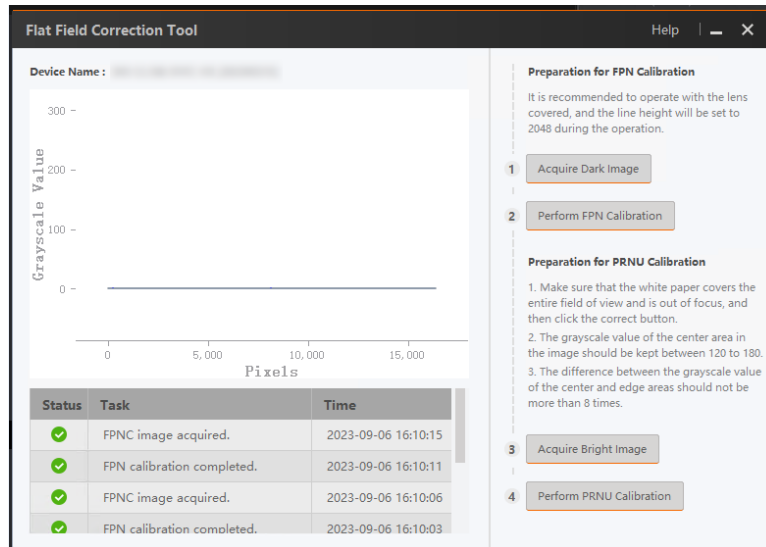

Figure 11-30 Flat Field Correction Tool

Note

- Refer to **Flat Field Correction Tool User Manual** for details.
- When the device supports **FPNC Correction**, you can click **Execute** in **FPNC Correction** to calculate correction data.

4. Enable **User Flat Field Correction**.

Note

After **User Flat Field Correction** is enabled, you can enable FPNC correction and PRNUC correction at the same time.

The status of FPNC correction process can be viewed via **Correction State**. There are five statuses in total:

- **All Finished**: It means that the correction is done.
- **Doing Correction**: It means that the correction is executing.
- **Saving Data**: It means that the correction data is saving.
- **Transferring Data**: It means that the correction data is sending.
- **Error**: It means that the correction fails.

Note

The status of PRNUC correction process can also be viewed via **Correction State**.

11.19.2 Set PRNUC Correction

The device supports PRNUC (Photo-Response Non-Uniformity Correction) function that eliminates vertical line on the images. Two correction methods are available, including global correction and ROI correction. The effect of PRNUC correction is shown blow.

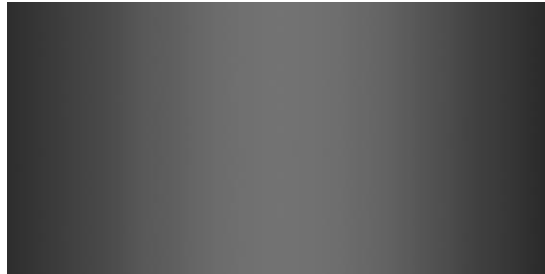

Figure 11-31 Before PRNUC Correction



Figure 11-32 After PRNUC Correction

Global PRNUC Correction

Steps

1. Click **Shading Correction**, and **User Flat Field Correction** is disabled by default.

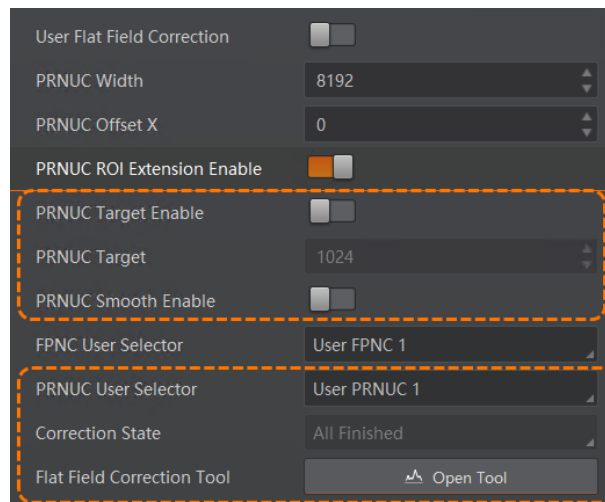

Figure 11-33 Set Shading Correction

2. Select one **User PRNUC** from **PRNUC User Selector**.
3. Set PRNUC target related parameters according to actual demands.
 - Disable **PRNUC Target Enable** if you want to use the device's auto correction standard. At this time, the device compares and corrects the average gray value of each column with the average gray value of the entire image.
 - Enable **PRNUC Target Enable** if you want to manually correct. For mono devices, set **PRNUC Target**. At this time, the device compares and corrects the average gray value of each column with the configured gray value.
4. Click **Open Tool** in **Flat Field Correction Tool** and click **Perform PRNUC Calibration**.

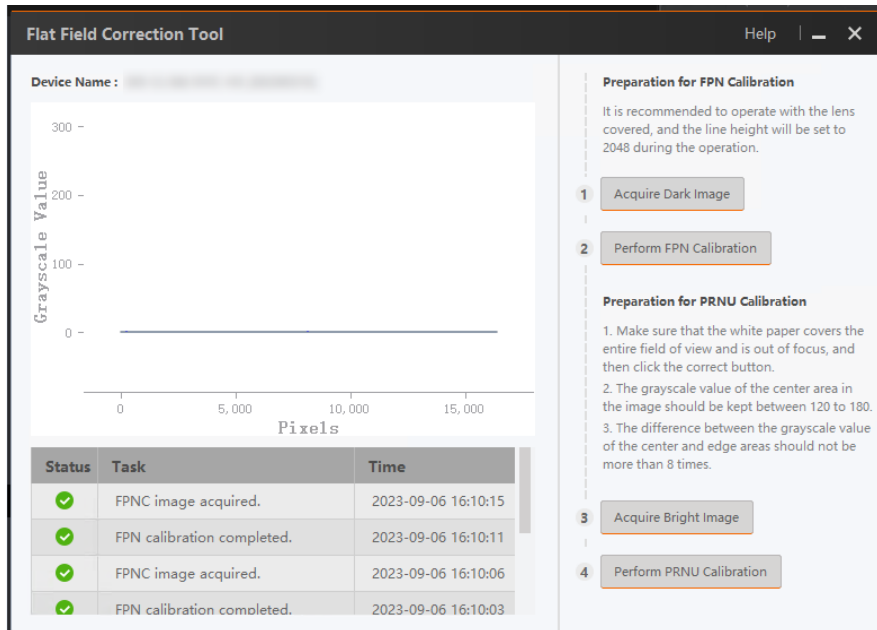

Figure 11-34 Flat Field Correction Tool

Note

- Refer to **Flat Field Correction Tool User Manual** for details.
- When the device supports **FPNC Correction**, you can click **Execute** in **FPNC Correction** to calculate correction data.

5. Enable **User Flat Field Correction**.

Note

After **User Flat Field Correction** is enabled, you can enable FPNC correction and PRNUC correction at the same time.

6. (Optional) Enable **PRNUC Smooth Enable** to reduce the dust impact during calibration process.

7. (Optional) After **PRNUC Smooth Enable** is enabled, you can set **PRNUC LowPass Filter** to adjust vertical line in image. Higher values reduce dust interference during calibration and enhance clarity of vertical line in the image. Lower values weaken the smoothing effect, resulting in more blurred line features. When the value is set as 0, it has the same effect as **PRNUC Smooth Enable** disabling.

ROI PRNUC Correction

If you want to execute PRNUC correction for specific areas, set **PRNUC Width** and **PRNUC Offset X** to set ROI, and enable **PRNUC ROI Extension Enable** to execute PRNUC Correction out of the ROI.

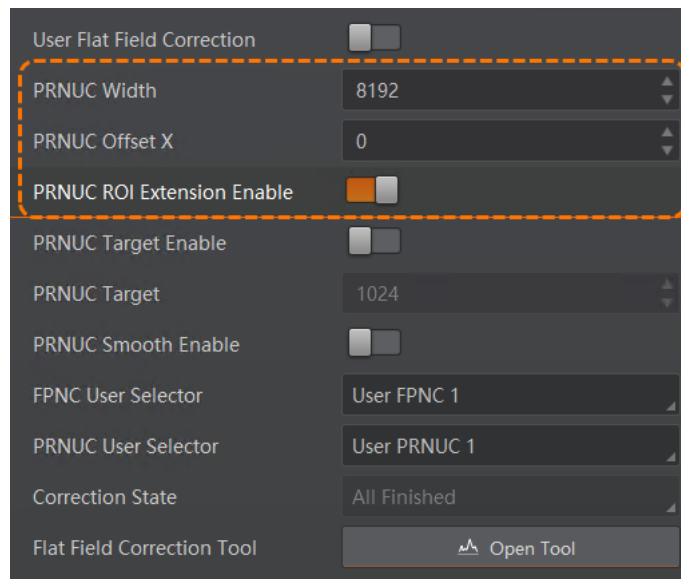

Figure 11-35 ROI PRNUC Correction

Note

Refer to section [Global PRNUC Correction](#) and *Flat Field Correction Tool User Manual* for details of flat field correction tool.

11.20 Set Space Correction

Note



- The space correction function may differ by device models.
 - The space correction function can be set only when **2/4-TDI** is selected as **TDI Mode**. Refer to [Set TDI Function](#) for details.
-

The space correction (SC) includes line rate deviation correction and parallax deviation correction, and they are used to reduce image details deviation caused by line rate deviation or pixel deviation.

11.20.1 Set Line Rate Ratio

You can go to **Image Format Control**, and set **Line Rate Ratio** according to actual demands. Line rate ratio is used to adjust the ratio between the device's line rate and that of the actual object to adjust the pixel deviation between upper line and lower line in images. Refer to the table below for effect contrast.

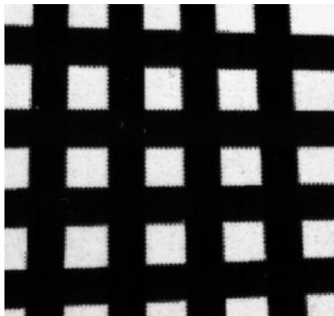
Table 11-4 Effect Contrast of Line Rate Ratio

Device Type	Normal Image	Abnormal Image
Mono Device		

- It is recommended to set line rate ratio larger than 1 when the device's line rate is larger than that of the object.
- It is recommended to set line rate ratio smaller than 1 when the device's line rate is smaller than that of the object.
- It is recommended to set line rate ratio as 1 when the device's line rate is equal to that of the object.

11.20.2 Set Pixel Shift and Parallax Direction

When pixel deviation occurs, images of mono devices are vague. If you find the image's edge has pixel deviation via observation, follow steps below to alleviate it. Refer to the table below for effect contrast.

Note

If the overall image has the phenomenon below, it may be caused by lens optical structure deviation.

Table 11-5 Effect Contrast of Pixel Shift

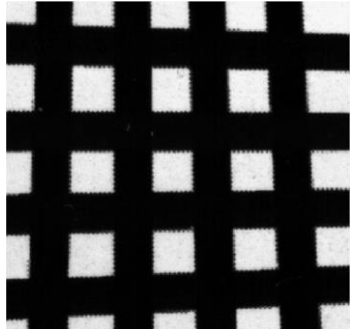
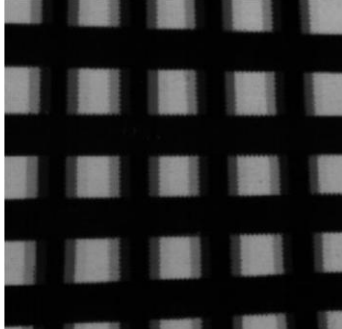
Device Type	Normal Image	Abnormal Image
Mono Device		

Steps

1. Set **Off** as **Parallax Direction** if the image's edge does not have pixel deviation.
2. Set **Parallax Direction** according to actual conditions if the image's edge has pixel deviation. For the mono device, if its upper sensor is closer to the measured objects, and select **Start Line** as **Parallax Direction**. Otherwise, select **End Line** instead.
3. Set **Pixel Shift** to have a best effect.

Chapter 12 Other Functions

12.1 Device Control

Note

The specific device control parameters may differ by device models.

In **Device Control**, you can view device information, edit device name, reset device, etc. The specific parameters in **Device Control** are shown below.

Table 12-1 Parameter Description

Parameter	Read/Write	Description
Device Scan Type	Read Only	It is the scan type of the device's sensor. LineScan refers to the line scan camera.
Device Vendor Name	Read Only	It is the name of the vendor.
Device Model Name	Read Only	It is the model of the device.
Device Manufacturer Info	Read Only	It is the information of the manufacturer.
Device Firmware Version	Read Only	It is the firmware version of the device.
Device Serial Number	Read Only	It is device's serial number.
Device User ID	Read & Write	It is the device name and is empty by default. You can set according to your preference. <ul style="list-style-type: none"> • If User ID is empty, the client software displays the device model (device serial number). • If you set it, the client software displays the User ID you set (device serial number).
Device Revision	Read Only	It is the version of CoaXPress protocol.
Device Manifest Size	Read Only	It is the GenICam XML quantity.
Device Manifest Selector	Read & Write	It is the ID of the selected GenICam XML.
Device Xml Version	Read Only	It is the version No. of GenICam XML.
Device Schema Version	Read Only	It is the version No. of GenICam structure.
Device Uptime (s)	Read Only	It is the device's operation time.

Parameter	Read/Write	Description
Board Device Type	Read Only	It is the device type.
Device Reset	Write	Click Execute to reset the device.
Device Temperature Selector	Read & Write	You can view sensor's temperature.
Device Temperature	Read Only	It displays the temperature of selected components in Device Temperature Selector .
Find Me	Read & Write	Click Execute to find the currently operating device, and the device red indicator flashes once.
Device PJ Number	Read Only	It is the project No.

12.2 Transport Layer Control

You can go to **Transport Layer Control** to view the device's payload size and image stream.

Note

The specific parameters of transport layer control may differ by device models.

Table 12-2 Parameters of Transport Layer Control

Parameter	Read/Write	Description
Payload Size	Read Only	It is the device's load size.
Device Tap Geometry	Read & Write	It is the tap configuration mode.
Image1 Stream ID	Read Only	It is the ID of image 1.

12.3 CoaXPress Interface Parameters

You can go to **CoaXPress** to view and set the parameters of CoaXPress interface.

Note

The specific **CoaXPress** parameters may differ by device models.

Table 12-3 CoaXPress Interface Parameters

Parameter	Read/Write	Description
Device Connection ID	Read Only	It is the device's connection ID.

CoaXPress Line Scan Camera User Manual

Parameter	Read/Write	Description
Master Host Connection ID	Read, and Write if not Acquisition	It is connected main host ID.
Control Packet Max Size	Read Only	It is the max. size of single control packet.
Device Steam Max Size	Read, and Write if not Acquisition	It is the max. size of single stream packet.
LinkConfiguration	Read, and Write if not Acquisition	It sets link configuration mode.
LinkConfigurationPreferred	Read Only	It is recommended link configuration mode. You can click Execute in User Set Save after configuring LinkConfiguration to save it. At this time, LinkConfigurationPreferred is related with LinkConfiguration .
ConnectionTestMode	Read & Write	It checks test data sent between the device and frame grabber.
TestErrorCountSelector	Read & Write	It selects link that needs checking test results.
TestErrorCount	Read & Write	It is error count of current link.
TestPacketCountTx	Read & Write	It is transmitted test data quantity of current link.
TestPacketCountRx	Read & Write	It is received test data quantity of current link.
TestPacketModeTx	Read & Write	You can select the mode of sending test data via current Link. <ul style="list-style-type: none"> ● When Mode 1 is selected, the test data is incremented byte by byte from 0 to 255 in cycles. ● When Mode 2 is selected, the test data is the specified value and the value set in TestPackedValue.
TestPacketModeRx	Read & Write	It is the groups of the test data sent by the current Link.
TestPackedValue	Read & Write	It is the value of the test data sent by the current Link.

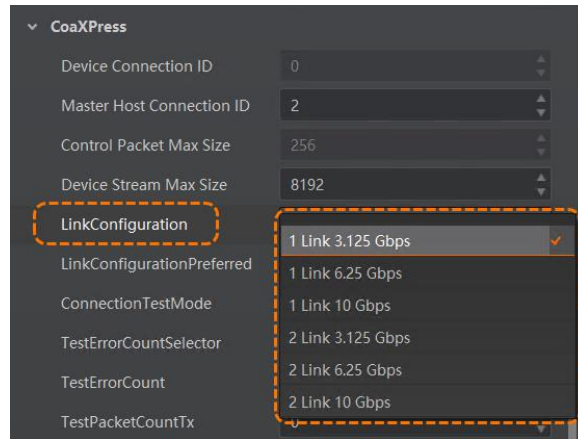

Figure 12-1 Link Configuration

12.4 Event Control

The event control can record events happen to the device and allow you to view them.

Steps

1. Go to **Event Control** → **Event Selector**, and select **Event Selector** according to actual demands.

Note

The specific events may differ by device models.

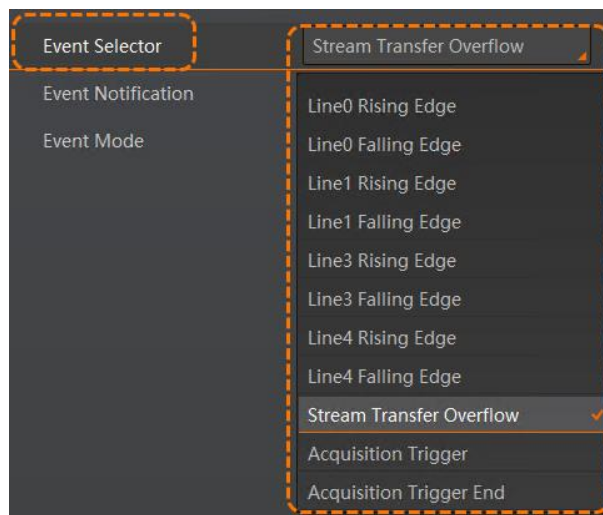

Figure 12-2 Event Selector

2. Select **Notification On** as **Event Notification** to output event.

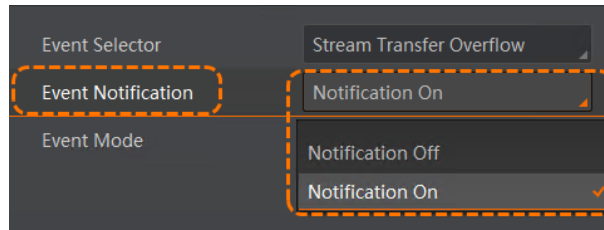

Figure 12-3 Set Event Control

3. Set event processing mode in **Event Mode**.
 - **Low Latency:** In this mode, the device processes event data sequentially, ensuring that each event achieves the minimum response time.
 - **High Through Put:** In this mode, the camera performs batch processing of multiple events, maximizing event throughput per unit time.
4. Right click the connected device and click **Event Monitor**.
5. Check **Messaging Channel Event**, and view specific event after device starts live view.

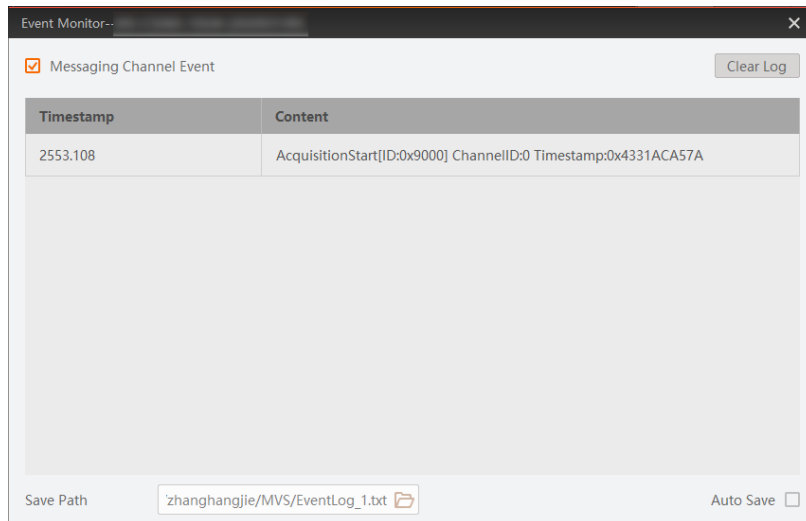

Figure 12-4 Event Monitor Window

12.5 File Access Control

Note

- The file access control function may differ by device model.
 - Importing and exporting the device feature, user PRNUC, and LUT among the same model and same firmware of devices are supported.
-

The file access function can import or export the device's feature files and save them in mfa format. The supported feature files include User Set 1/2/3, LUT Luminance 1/2/3, USER PRNUC 1/2/3, USER FPNC 1/2/3, and License Notice.

Steps

1. Select a device in the device list, and click  to open the file access dialogue box.



Figure 12-5 File Access

2. Select **Device Feature** and click **Import** or **Export**.

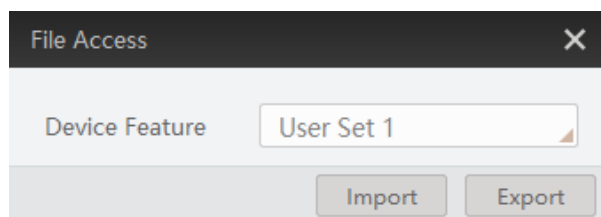

Figure 12-6 Import or Export

3. Select a file in MFA format from local PC to import, or select a saving path and enter file name to save and export.

Note

- If **User Set 1/2/3** is selected as device feature, you need to load the corresponding user set you selected to take effect.
 - If **LUT Luminance 1/2/3** is selected as device feature, it will take effect only when you select the same parameters in LUT Selector.
 - The **USER PRNUC 1/2/3** has the same mechanism with **LUT Luminance 1/2/3** mentioned above.
 - If **USER FPNC 1/2/3** is selected as device feature, it will take effect immediately when **FPNC User Enable** is enabled.
 - If **License Notice** is selected as device feature, it will take effect immediately when it is imported.
-

12.6 Update Firmware

You can use the **Firmware Upgrade Tool** to update the device's firmware.

Note

The MVS Tool Kit is installed by default when you install the MVS client software.

Steps

1. Go to **Tool** → **Toolkit** to open MVS Tool Kit.
2. Go to **All** → **Configuration Tool** → **Firmware Upgrade Tool** after running MVS Tool Kit.
3. Select **Camera** from **Select Type**.
4. The tool automatically refreshes and enumerates all the devices searched by the frame grabber.
5. Click  to select firmware upgrade package (dav file).
6. Click **Update** to start updating.

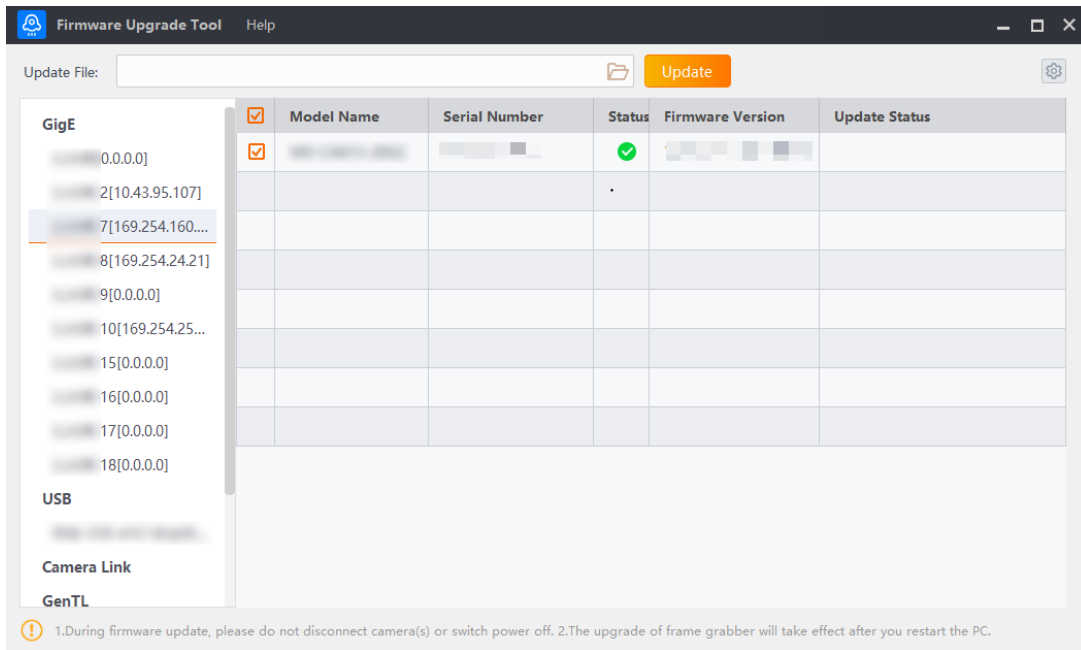

Figure 12-7 Update Firmware

Note

- The device will restart automatically after updating the firmware.
- The firmware updating process may take a few minutes. Please wait patiently.
- During firmware updating, do not disconnect the device or switch power off.

12.7 User Set Customization

This function allows you to save or load device settings. The device supports four sets of parameters, including one default set and three user sets, and the relation among four sets of parameters is shown below.

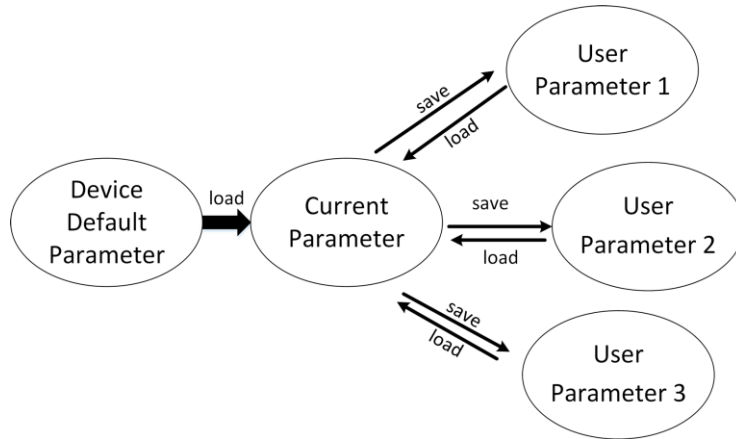

Figure 12-8 Parameter Relation

Note

After setting user parameters, it is recommended to save user parameters and select them as the default parameters.

12.7.1 Save User Set

Steps

1. Go to **User Set Control**, and select a user set in **User Set Selector**.

Note

Here we take selecting **User Set 1** as an example.

2. Click **Execute** in **User Set Save** to save parameter.

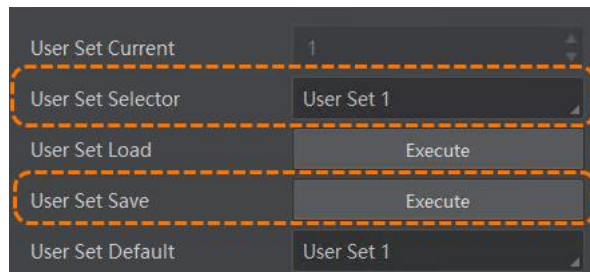

Figure 12-9 Save User Set

12.7.2 Load User Set

Note

Loading user set is available only when the device is connected but without live view.

Steps

1. Go to **User Set Control**, and select a user set in **User Set Selector**.
-

Note

Here we take selecting **User Set 1** as an example.

2. Click **Execute** in **User Set Load** to load parameter.

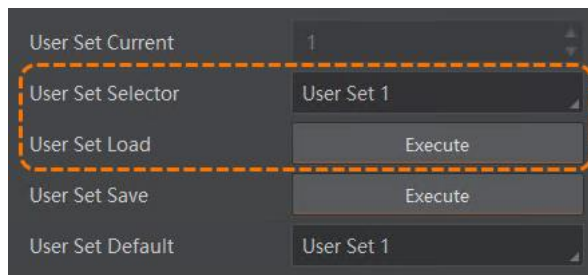

Figure 12-10 Load User Set

12.7.3 Set User Default

You can also set default parameter by going to **User Set Control** and selecting a user set in **User Set Default**.

Note

Here we take selecting **User Set 1** as an example.

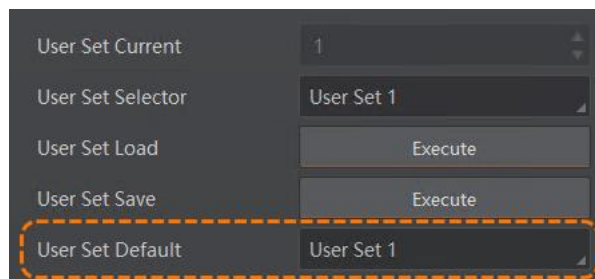

Figure 12-11 Set User Default

Chapter 13 FAQ (Frequently Asked Question)

13.1 Why the client software cannot list devices?

Table 13-1 Question 1

Possible Cause	Solution
The device is not powered on.	Check the device's power supply by observing the device LED indicator.
Incorrect CoaXPress cable connection.	Check connection of CoaXPress cable.

13.2 Why the live view is black?

Table 13-2 Question 2

Possible Cause	Solution
The device's lens aperture is not removed.	Remove the device's lens aperture.

13.3 Why the device cannot be triggered although the live view is normal?

Table 13-3 Question 3

Possible Cause	Solution
The trigger mode is not enabled.	Enable the trigger mode and make sure that the selected trigger source matches with the corresponding I/O signal.
Incorrect trigger wiring.	Check if the input of trigger signal and wiring are correct or not.

13.4 Why images required by algorithm cannot get although the live view and trigger signal are normal?

Table 13-4 Question 4

Possible Cause	Solution
The image's output format is not matched with the algorithm.	Check the image format required by the algorithm, and configure the device's image output format in the client software.

Chapter 14 Revision History

Table 14-1 Revision History

Version	Revision Date	Revision Details
V1.0.1	Dec. 25, 2025	<ul style="list-style-type: none"> ● Edit Section Appearance. ● Add Section Set Sharpness. ● Add Section Set Digital Noise Reduction. ● Add Section Set Sequence. ● Edit Section Set Shading Correction. ● Edit Section Device Control. ● Edit Section Transport Layer Control. ● Add Section Event Control.
V1.0.0	Oct. 9, 2024	Original version.

Appendix A Device Parameter Index

A.1 Device Control

Table A-1 Device Control

Parameters	Section
Device Scan Type	Section Device Control
Device Vendor Name	
Device Model Name	
Device Manufacturer Info	
Device Firmware Version	
Device Serial Number	
Device User ID	
Device Revsion	
Device Manifest Size	
Device Manifest Selector	
Device Xml Version	
Device Schema Version	
Device Uptime(s)	
Board Device Type	
Device Reset	
Device Temperature Selector	
Device Temperature	
Find Me	
Device PJ Number	

A.2 Image Format Control

Table A-2 Image Format Control

Parameters	Section
Width Max	Section Set Resolution and ROI
Height Max	
Region Selector	
Width	
Height	
Offset X	
Reverse X	Section Set Image Reverse
Pixel Format	Section Set Pixel Format
Pixel Size	
Multi Light Control	Section Set Multiple Lights Control
Multi Exposure0 (us)	
Multi Gain0 (dB)	
Multi Exposure1 (us)	
Multi Gain1 (dB)	
Sequence Exposure Enable	Section Set Sequence
Sequence Exposure Number	
Sequence Exposure Selector	
Sequence Exposure Time(us)	
Sequence Exposure Gain	
Test Pattern	Section Set Test Pattern
Binning Selector	Section Set Binning
Binning Horizontal	
Binning Vertical	
TDI Mode	Section Set TDI Function
Direction Source	Section Set Scan Direction
Reverse Scan Direction	
Sensor Mode	Section Set Sensor Mode

Abnormal Line Enable	Section Set Line Discard Function
Line Rate Ratio	Section Set Space Correction
Pixel Shift	
Parallax Direction	

A.3 Acquisition and Transfer Control

Table A-3 Acquisition and Transfer Control

Parameters	Section
Acquisition Mode	Section Set Line Rate
Acquisition Start	
Acquisition Stop	
Acquisition Burst Frame Count	Section Set Acquisition Burst Frame Count
Acquisition Line Rate (Hz)	Section Set Line Rate
Acquisition Line Rate Control Enable	
Resulting Line Rate (Hz)	
Resulting Frame Rate (Fps)	
Scan Mode	Section Set Scan Mode
FrameTrigger Mode	Section Trigger Input
FrameTrigger Source	
FrameTrigger Activation	
Line Delay Enable	
FrameTrigger Delay	
FrameTrigger Cache Enable	
LineTrigger Mode	
LineTrigger Source	
LineTrigger Activation	
LineTrigger Delay	
LineTrigger Cache Enable	

Exposure Mode	Section Set Exposure Mode
Exposure Time (μ s)	
Exposure Auto	
Auto Exposure Time Lower Limit (μ s)	
Auto Exposure Time Upper Limit (μ s)	
Frame Timeout Enable	Section Set Frame Timeout
Frame Timeout Time (μ s)	
Partial Image Output Mode	
Device Connection ID	Section CoaXPress Interface Parameters
Master Host Connection ID	
Control Packet Max Size	
Device Stream Max Size	
LinkConfiguration	
LinkConfigurationPreferred	
ConnectionTestMode	
TestErrorCountSelector	
TestErrorCount	
TestPacketCountTx	
TestPacketCountRx	
TestPacketModeTx	
TestPacketModeRx	
TestPackedValue	
Payload Size	
Device Tap Geometry	
Image1StreamID	

A.4 Advanced Processing

Table A-4 Advanced Processing

Parameters	Section
Preamp Gain	Section Set Analog Gain

Gain (dB)	
Digital Shift	Section Set Digital Gain
Digital Shift Enable	
Brightness	Section Set Brightness
Black Level	Section Set Black Level
Black Level Enable	
Gamma	Section Set Gamma Correction
Gamma Selector	
Gamma Enable	
Sharpness Enable	Section Set Sharpness
Sharpness	
Digital Noise Reduction Mode	Section Set Digital Noise Reduction
Denoise Strength	
Noise Correct	
Auto Function AOI Selector	Section Set AOI
Auto Function AOI Width	
Auto Function AOI Height	
Auto Function AOI Offset X	
Auto Function AOI Offset Y	
Auto Function AOI Usage Intensity	
LUT Selector	Section Set LUT
LUT Enable	
LUT Index	
LUT Value	
LUT Save	

A.5 Shading Correction

Table A-5 Shading Correction

Parameters	Section
User Flat Field Correction	Section Set Shading Correction

PRNUC Width
PRNUC Offset X
PRNUC ROI Extension Enable
PRNUC Target Enable
PRNUC Target
PRNUC Smooth Enable
PRNUC LowPass Filter
FPNC User Selector
PRNUC User Selector
FPNC Correction
PRNUC Correction
Correction State
Flat Field Correction Tool

A.6 I/O Control

Table A-6 I/O Control

Parameters	Section
Line Selector	
Line Mode	
Line Format	
Line Inverter	
Line Status	
Line Status All	
Line Debouncer Time (ns)	
Line Source	
Line Trigger Software	
Hardware Trigger Source	
Hardware Trigger Activation	
Strobe Enable	
Strobe Source Selector	

Section [Trigger Output](#)

Strobe Line Duration (μs)	
Strobe Line Delay (μs)	
Strobe Line Pre Delay (μs)	
Encoder Selector	Section Set and Execute Shaft Encoder Control
Encoder Source A	
Encoder Source B	
Encoder Trigger Mode	
Encoder Counter Mode	
Encoder Counter	
Encoder Counter Max	
Encoder Counter Reset	
Encoder Max Reverse Counter	
Encoder Reverse Counter Reset	
Input Source	
Signal Alignment	
Trigger Line Rate(Hz)	
PreDivider	
Multiplier	
PostDivider	
Resulting Trigger Line Rate(Hz)	
Counter Selector	Section Enable Strobe Signal
Counter Event Source	
Counter Event Activation	
Counter Reset Source	
Counter Reset	
Counter Value	
Counter Current Value	

A.7 Event Control

Table A-7 Event Control

Parameters	Section
Event Selector	Section Event Control
Event Notification	
Event Mode	

A.8 User Set Control

Table A-8 User Set Control

Parameters	Section
User Set Current	Section User Set Customization
User Set Selector	
User Set Load	
User Set Save	
User Set Default	



HIKROBOT

SHAPE OUR FUTURE INTELLIGENTLY

Hikrobot Co., Ltd.

Tel: 400-989-7998

Website: <https://en.hikrobotics.com/>

UD45231B