

# MV-CL083-91F2C

## 8192 P XoF Color Line Scan Camera

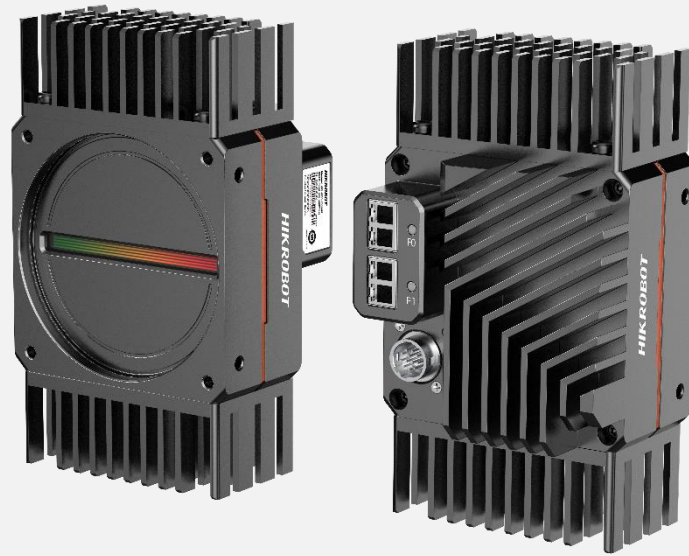

### Introduction

MV-CL083-91F2C camera adopts RGB true color CMOS sensor and supports transmission over its 20G fiber port, and its max. line rate reaches 66.6 kHz. It adopts multiple ISP image processing technologies, and is featured with high speed, high accuracy, and high performance.

### Key Feature

- Adopts multiple ISP like Gamma, flat field correction, LUT, black level offset, etc.
- Provides 20G fiber port to transmit data with max. line rate of 66.6 kHz.
- Supports RGB true color, multiple exposure and acquisition methods.
- Adopts bi-directional configurable I/O hardware design.
- Compact design and flexible installation.

### Dimension

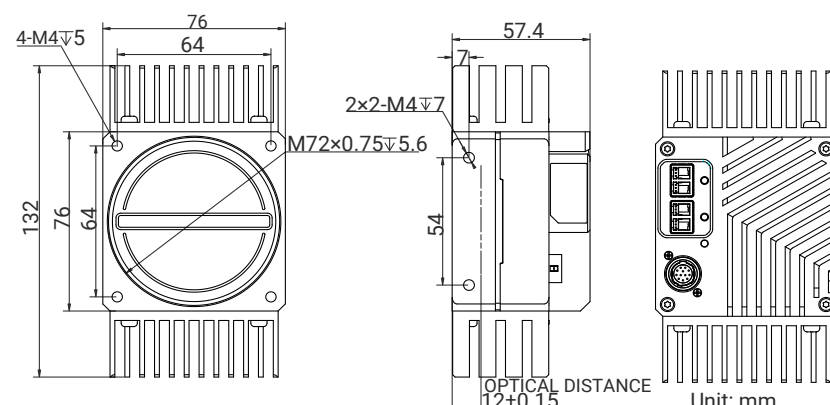

### Available Model

MV-CL083-91F2C

### Applicable Industry

New energy, screen detection, consumer electronics, PCB, etc.

### Sensor Quantum Efficiency

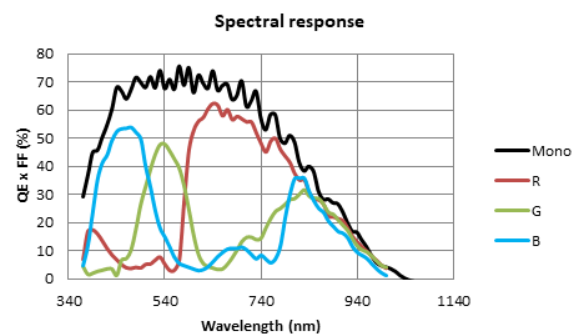

### Accessories

- Frame Grabber: MV-GS1002F
- SFP+ Module: MV-AC10G-SFP
- Fiber Patch Cable: MV-AC10G-2LC-2LC-ST

## Specification

<b>Model</b>	<b>MV-CL083-91F2C</b>
<b>Performance</b>	
<b>Sensor type</b>	CMOS
<b>Pixel size</b>	7 $\mu\text{m}$ $\times$ 7 $\mu\text{m}$
<b>Resolution</b>	8192 $\times$ 3
<b>Image mode</b>	Supports 1-Line
<b>Max. line rate</b>	66.6 kHz
<b>Transmission mode</b>	1 Link, 2 Link
<b>Dynamic range</b>	63.4 dB
<b>SNR</b>	40.8 dB
<b>Gain</b>	1.0 $\times$
<b>Exposure time</b>	3 $\mu\text{s}$ to 10 ms
<b>Exposure mode</b>	Off/Once/Continuous exposure mode, and supports trigger-width exposure
<b>Mono/color</b>	Color
<b>Pixel format</b>	Mono 8/12, RGB 8, BGR 8
<b>Binning</b>	Supports 1 $\times$ 1, 1 $\times$ 2, 1 $\times$ 4, 2 $\times$ 1, 2 $\times$ 2, 2 $\times$ 4, 4 $\times$ 1, 4 $\times$ 2, 4 $\times$ 4
<b>Reverse image</b>	Supports horizontal reverse image output
<b>Trigger mode</b>	External trigger, internal trigger
<b>External trigger mode</b>	Line trigger, frame trigger, line + frame trigger
<b>Electrical feature</b>	
<b>Data interface</b>	2LC fiber connector
<b>Digital I/O</b>	12-pin P10 connector provides power and I/O: Configurable input/output $\times$ 4 (Line 0/1/3/4) and single-ended/differential is supported.
<b>Power supply</b>	12 VDC to 24 VDC
<b>Power consumption</b>	Typ. 14 W @ 24VDC
<b>Mechanical</b>	
<b>Lens mount</b>	M72*0.75, flange back length 12 mm, applicable to F-mount via lens adapter
<b>Dimension</b>	132 mm $\times$ 76 mm $\times$ 57.4 mm (5.2" $\times$ 3.0" $\times$ 2.3")
<b>Weight</b>	Approx. 600 g (1.3 lb.)
<b>Ingress protection</b>	IP40 (under proper lens installation and wiring)
<b>Temperature</b>	Working temperature: -20 $^{\circ}\text{C}$ to 50 $^{\circ}\text{C}$ (-4 $^{\circ}\text{F}$ to 122 $^{\circ}\text{F}$ ) Storage temperature: -30 $^{\circ}\text{C}$ to 80 $^{\circ}\text{C}$ (-22 $^{\circ}\text{F}$ to 176 $^{\circ}\text{F}$ )
<b>Humidity</b>	5% RH to 90% RH (no condensation)
<b>General</b>	
<b>Client software</b>	MVS
<b>Operating system</b>	32/64-bit Windows 7/10, 64-bit Windows 11
<b>Compatibility</b>	Self-developed protocol, GenICam
<b>Certification</b>	CE, RoHS, KC