

MV-CL082-92GM

8192 P CMOS GigE Line Scan Camera



GEN<i>i>CAM

GIG<i>E</i>
VISION

Introduction

MV-CL082-92GM camera adopts 8192 × 2 line CMOS sensor with pixel size of 7 μm × 7 μm, integrates multiple latest ISP image algorithms and functions, and supports external trigger modes like line trigger, frame trigger, and trigger-width exposure. It uses GigE interface to transmit images in real time, and supports high bandwidth function to increase max. line rate.

Key Feature

- Supports high bandwidth image compression mode, TDI, trigger-width exposure, etc.
- Rich ISP image algorithms and supports manual adjustment for Gamma correction, flat field correction, LUT, black level, etc.
- Adopts bi-directional I/O hardware design.
- Compact design and flexible installation.
- Compatible with GigE Vision V2.0 and GenICam standard.

Available Model

MV-CL082-92GM

Applicable Industry

New energy, screen detection, consumer electronics, PCB, food & pharmaceuticals, material sorting, etc.

Sensor Quantum Efficiency

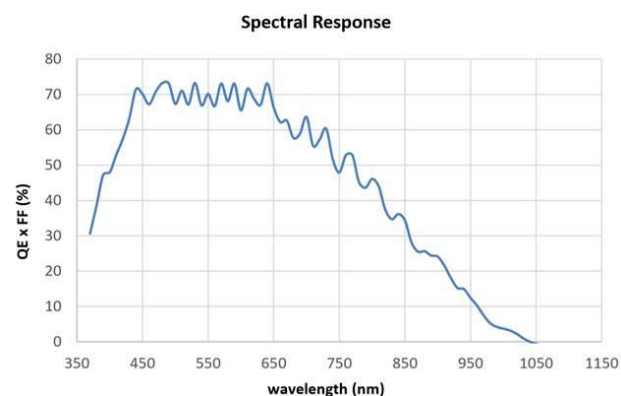

Dimension

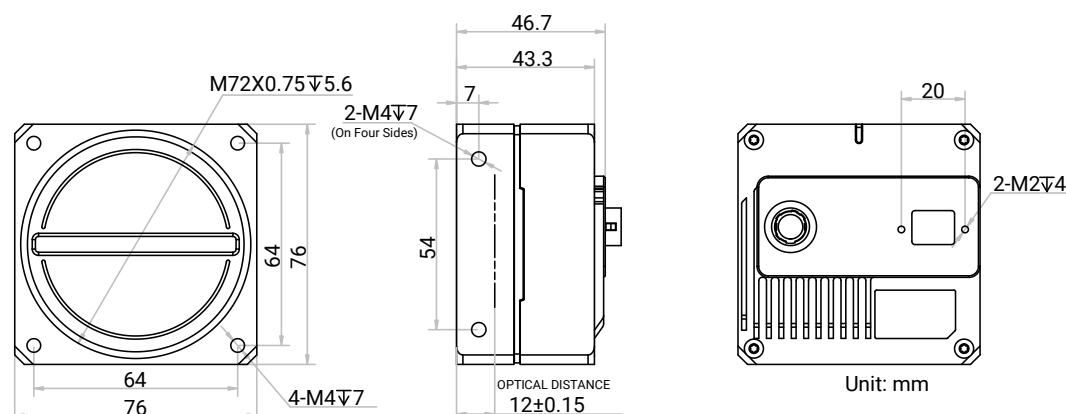

Specification

Model	MV-CL082-92GM
Performance	
Sensor type	CMOS
Pixel size	7 μm × 7 μm
Resolution	8192 × 2
Image mode	Supports 1-line, 2-TDI
Max. line rate	Standard mode: 14 kHz @ Mono 8, 7 kHz @ Mono 10/12 High-bandwidth mode: 50 kHz @ Mono 8/10/12
Dynamic range	63.4 dB
SNR	40.8 dB
Gain	1.0 ×
Exposure time	3 μs to 10 ms
Exposure mode	Off/ Once/ Continuous exposure mode, and supports trigger-width exposure
Mono/color	Mono
Pixel format	Mono 8/10/12
Binning	Supports 1 × 1, 1 × 2, 1 × 4, 2 × 1, 2 × 2, 2 × 4, 4 × 1, 4 × 2, 4 × 4
Reverse image	Supports horizontal reverse image output
Trigger mode	External trigger, internal trigger
External trigger mode	Line trigger, frame trigger, line + frame trigger
Electrical feature	
Data interface	Gigabit Ethernet, compatible with Fast Ethernet
Digital I/O	12-pin P10 connector provides power and I/O: configurable input or output × 4 (Line 0/1/3/4) and supports single-ended/differential
Power supply	12 VDC to 24 VDC
Power consumption	Typ. 6.8 W @ 12 VDC
Mechanical	
Lens mount	M72*0.75, flange back length 12 mm, applicable to F-mount, C-mount and others via adapter
Dimension	76 mm × 76 mm × 46.7 mm (3.0" × 3.0" × 1.8")
Weight	Approx. 400 g (0.9 lb.)
Ingress protection	IP40 (under proper lens installation and wiring)
Temperature	Working temperature: -20 °C to 50 °C (-4 °F to 122 °F) Storage temperature: -30 °C to 80 °C (-22 °F to 176 °F)
Humidity	5% RH to 90% RH (no condensation)
General	
Client software	MVS or the third-party software meeting with GigE Vision protocol
Operating system	32/64-bit Windows 7/10, 64-bit Linux
Compatibility	GigE Vision V2.0, GenICam
Certification	CE, RoHS, KC