

# MV-CL042-91FM

## 4096 P XoF Mono Line Scan Camera



### Introduction

MV-CL042-91FM camera adopts 4096 × 2 mono CMOS sensor and supports transmission protocol of XoFLink, and its max. line rate reaches 195 kHz. It adopts multiple ISP image processing technologies, and is featured with high speed, high accuracy, and high performance.

### Key Feature

- Adopts multiple ISP like Gamma correction, flat field correction, LUT, black level offset, etc.
- Provides one XoF fiber port, and supports multiple exposure and acquisition methods with max. line rate of 195 kHz.
- Adopts bi-directional configurable I/O hardware design.
- Compact design and flexible installation.
- Supports removable heat sink for compact installation in non-high-temperature environments.

### Dimension

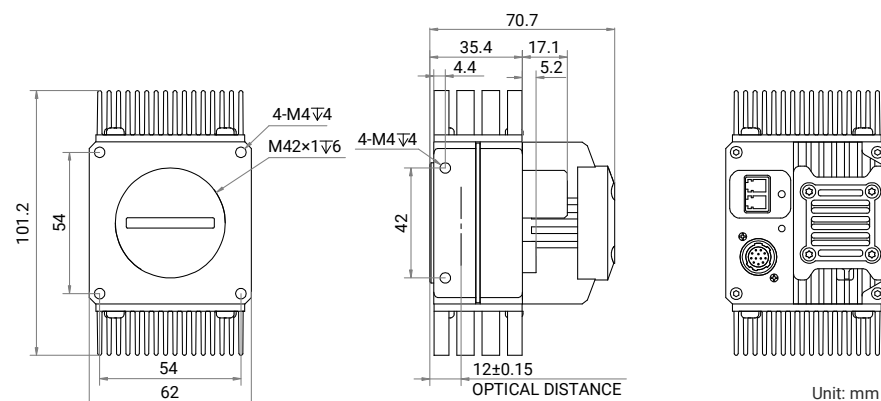

### Available Model

MV-CL042-91FM

### Applicable Industry

New energy, consumer electronics, textile, railway, etc.

### Sensor Quantum Efficiency

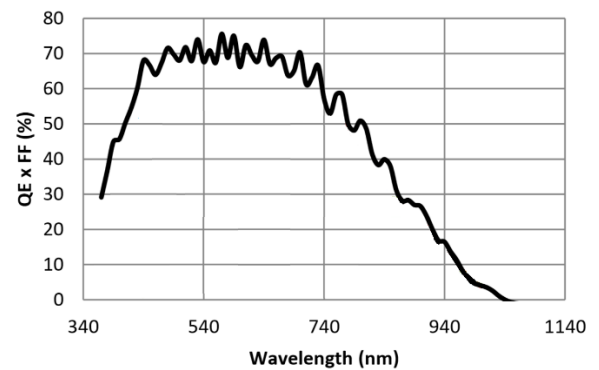

### Accessories

- Frame Grabber: MV-GS1002F, MV-GS1004F (optical module excluded)
- Optical Module: MV-AC10G-SFP
- Fiber Patch Cable: MV-AC10G-2LC-2LC-ST

## Specification

<b>Model</b>	<b>MV-CL042-91FM</b>
<b>Performance</b>	
<b>Sensor type</b>	CMOS
<b>Pixel size</b>	7 μm × 7 μm
<b>Resolution</b>	4096 × 2
<b>Image mode</b>	Supports 1-Line, 2-TDI
<b>Max. line rate</b>	195 kHz (1-Line), 100 kHz (2-TDI)
<b>Transmission mode</b>	1 Link
<b>Dynamic range</b>	67.6 dB
<b>SNR</b>	40.1 dB
<b>Gain</b>	1.0 ×, 1.4 ×, 1.6 ×, 2.4 ×, 3.2 ×
<b>Exposure time</b>	3 μs to 10 ms
<b>Exposure mode</b>	Off/ Once/ Continuous exposure mode
<b>Mono/color</b>	Mono
<b>Pixel format</b>	Mono 8/10/12
<b>Binning</b>	Supports 1 × 1, 1 × 2, 1 × 4, 2 × 1, 2 × 2, 2 × 4, 4 × 1, 4 × 2, 4 × 4
<b>Reverse image</b>	Supports horizontal reverse image output
<b>Trigger mode</b>	External trigger, internal trigger
<b>External trigger mode</b>	Line trigger, frame trigger, line + frame trigger
<b>Electrical feature</b>	
<b>Data interface</b>	LC fiber connector
<b>Digital I/O</b>	12-pin P10 connector provides power and I/O: Configurable input/output × 4 (Line 0/1/3/4) and single-ended/differential is supported.
<b>Power supply</b>	12 VDC to 24 VDC
<b>Power consumption</b>	Typ. 8.8 W @ 12 VDC
<b>Mechanical</b>	
<b>Lens mount</b>	M42*1.0, flange focal length 12 mm, applicable to F-mount via lens adapter
<b>Dimension</b>	101.2 mm × 62 mm × 70.7 mm (4.0" × 2.4" × 2.8")
<b>Weight</b>	Approx. 300 g (0.7 lb.)
<b>Ingress protection</b>	IP40 (under proper lens installation and wiring)
<b>Temperature</b>	Working temperature: -20 °C to 55 °C (-4 °F to 131 °F) Storage temperature: -30 °C to 80 °C (-22 °F to 176 °F)
<b>Humidity</b>	5% RH to 90% RH (no condensation)
<b>General</b>	
<b>Client software</b>	MVS
<b>Operating system</b>	32/64-bit Windows 7/10, 64-bit Windows 11
<b>Compatibility</b>	XoFLink, GenICam
<b>Certification</b>	CE, RoHS, KC