

# MV-CL024-91GM

## 2048 P CMOS GigE Line Scan Camera



GEN*i*CAM

GigE  
VISION

### Introduction

MV-CL024-91GM camera adopts CMOS sensor to provide high-quality images and integrates multiple ISP image algorithms and functions. It supports line trigger, frame trigger, line + frame trigger, etc. It uses GigE interface to transmit images in real time and its max. line rate can reach 86 kHz in high-bandwidth mode.

### Key Feature

- Supports TDI and image high-bandwidth function.
- Supports Gamma correction, FFC correction, LUT, black level, etc.
- Adopts bi-directional I/O and flexible configuration for input/output signals.
- Supports flexible installation from different sides.
- Compatible with GigE Vision V2.0 protocol and GenICam standard.

### Available Model

MV-CL024-91GM

### Applicable Industry

Photovoltaics, lithium battery, railway, textiles, logistics, metallurgy, material sorting, etc.

### Sensor Quantum Efficiency

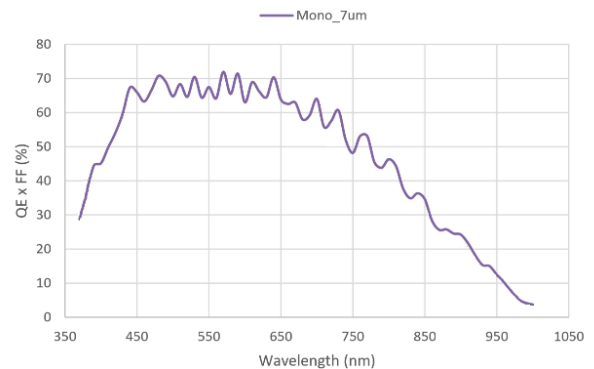

### Dimension

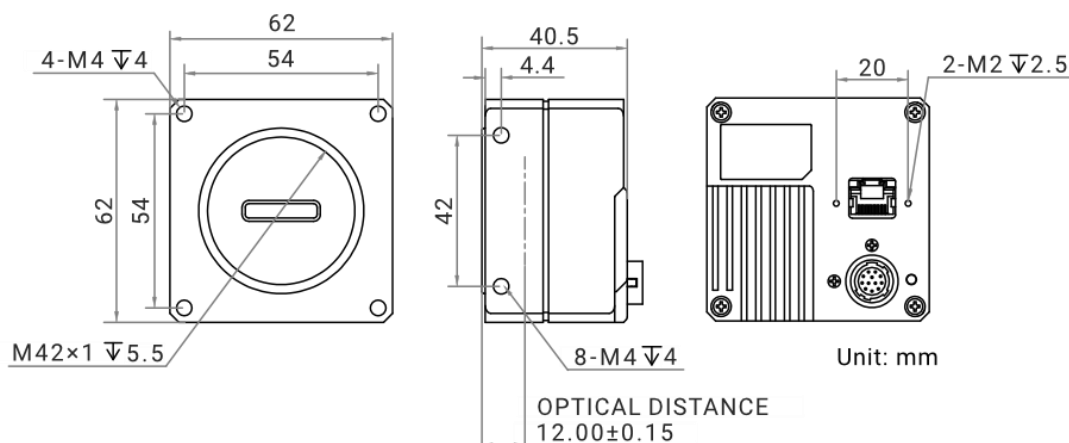

## Specification

<b>Model</b>	<b>MV-CL024-91GM</b>
<b>Camera</b>	
<b>Sensor type</b>	CMOS
<b>Pixel size</b>	7 μm × 7 μm
<b>Resolution</b>	2048 × 2
<b>Image mode</b>	Supports 1-line, 2-TDI
<b>Max. line rate*</b>	Standard mode: 58 kHz @ Mono 8, 29 kHz @ Mono 10/12 High-bandwidth mode: 86 kHz @ Mono 8, 58 kHz @ Mono 10/12
<b>Dynamic range</b>	68 dB
<b>SNR</b>	44.7 dB
<b>Gain</b>	1.0 ×
<b>Exposure time</b>	3 μs to 10 ms
<b>Exposure mode</b>	Off/Once/Continuous exposure mode, and supports trigger-width exposure
<b>Mono/color</b>	Mono
<b>Pixel format</b>	Mono 8/10/12
<b>Binning</b>	Supports 1 × 1, 2 × 2, 4 × 4
<b>Reverse image</b>	Supports horizontal reverse image output
<b>Trigger mode</b>	External trigger, internal trigger
<b>External trigger mode</b>	Line trigger, frame trigger, line + frame trigger
<b>Electrical feature</b>	
<b>Data interface</b>	Gigabit Ethernet (1000 Mbit/s), compatible with Fast Ethernet (100 Mbit/s)
<b>Digital I/O</b>	12-pin P10 connector provides power and I/O: Configurable input/output × 4 (Line 0/1/3/4) and single-ended/differential is supported.
<b>Power supply</b>	12 VDC to 24 VDC, supports PoE
<b>Power consumption</b>	Typ. 5.2 W @ 12 VDC
<b>Mechanical</b>	
<b>Lens mount</b>	M42*1.0, flange back length 12 mm, applicable to F-mount, C-mount and others via lens adapter
<b>Dimension</b>	62 mm × 62 mm × 40.5 mm (2.4" × 2.4" × 1.6")
<b>Weight</b>	Approx. 256 g (0.6 lb.)
<b>Ingress protection</b>	IP40 (under proper lens installation and wiring)
<b>Temperature</b>	Working temperature: -20 °C to 55 °C (-4 °F to 131 °F) Storage temperature: -30 °C to 80 °C (-22 °F to 176 °F)
<b>Humidity</b>	5% RH to 90% RH (no condensation)
<b>General</b>	
<b>Client software</b>	MVS or the third-party software meeting with GigE Vision protocol
<b>Operating system</b>	32/64-bit Windows 7/10, 64-bit Windows 11, 32/64-bit Linux
<b>Compatibility</b>	GigE Vision V2.0, GenICam
<b>Certification</b>	CE, RoHS, KC

\*The actual line rate after enabling high-bandwidth mode depends on images of objects, and max. line rate in high-bandwidth mode is for reference only.