

MV-CH610-10TM/TC

61 MP 10 GigE Area Scan Camera



GEN*i*CAM

10GigE
VISION

Introduction

MV-CH610-10TM/TC camera adopts Sony® IMX455 CMOS sensor to provide high-quality image. It uses 10 GigE interface to transmit non-compressed image in real time, and its max. frame rate can reach 17.9 fps in full resolution.

Available Model

- Mono camera: MV-CH610-10TM-F-TF
- Color camera: MV-CH610-10TC-F-TF

Applicable Industry

PCB AOI, FPD, railway-related applications, PV, etc.

Sensor Quantum Efficiency

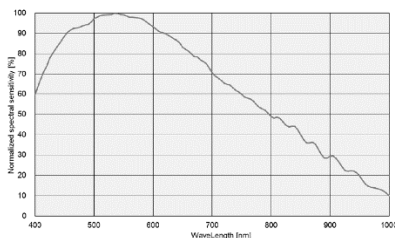

MV-CH610-10TM

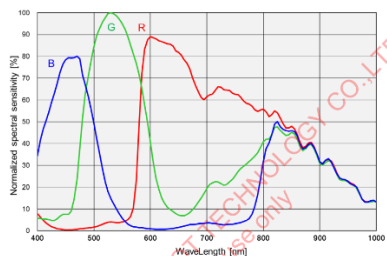

MV-CH610-10TC

Key Feature

- Provides highly-integrated hardware platform, and supports low power consumption and high cooling efficiency.
- Adopts a new design with a detachable lens mount.
- Adopts 10 GigE interface providing max. transmission distance of 100 meters without relay.
- Adopts TEC to reduce sensor temperature and ensure high-quality images under long-time exposure condition.
- Supports 16-bit ADC output with high-precision sampling and high dynamic range.
- Compatible with GigE Vision Protocol V2.0, GenICam Standard, and third-party software based on protocols.

Dimension

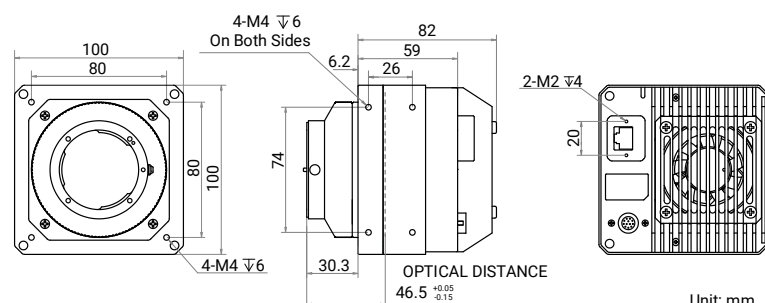

Specification

Model	MV-CH610-10TM	MV-CH610-10TC
Performance		
Sensor type	CMOS, rolling shutter	
Sensor model	Sony® IMX455	
Pixel size	3.76 μm × 3.76 μm	
Sensor size	36 mm × 24 mm	
Resolution	9568 × 6380	
Max. frame rate	17.9 fps @ 9568 × 6380 Mono 8	17.9 fps @ 9568 × 6380 Bayer RG 8
Dynamic range	75.3 dB	
SNR	46.8 dB	
Gain	0 dB to 36 dB	
Exposure time	9 μs to 10 sec	
Exposure mode	Off/Once/Continuous exposure mode, supports Global Reset	
Mono/color	Mono	Color
Pixel format	Mono 8/10/10Packed/12/12Packed/16	Mono 8/10/12/16 Bayer RG 8/10/10Packed/12/12Packed/16 YUV422_8, YUV422_8_YUYV RGB 8, BGR 8
Binning	Supports 1 × 1, 1 × 2, 1 × 4, 2 × 1, 2 × 2, 2 × 4, 4 × 1, 4 × 2, 4 × 4	
Decimation	Supports 1 × 1, 1 × 2, 1 × 4, 2 × 1, 2 × 2, 2 × 4, 4 × 1, 4 × 2, 4 × 4	
Reverse image	Supports horizontal reverse image output	
Electrical feature		
Data interface	10 Gigabit Ethernet (10000 Mbit/s), compatible with Gigabit Ethernet (1000 Mbit/s)	
Digital I/O	12-pin P10 connector provides power and I/O, including opto-isolated input × 1 (Line 0), opto-isolated output × 1 (Line 1), bi-directional non-isolated I/O × 1 (Line 2), and RS-232 × 1.	
Power supply	24 VDC	
Power consumption	Typ. 14.4 W @ 24 VDC (non-TEC mode) Typ. 27.6 W @ 24 VDC (TEC mode)	
Mechanical		
Lens mount	F-mount, flange back length 46.5 mm	
Dimension	100 mm × 100 mm × 82 mm (3.9" × 3.9" × 3.2")	
Weight	Approx. 1090 g (2.4 lb.)	
Ingress protection	IP40 (under proper lens installation and wiring)	
Temperature	Working temperature: 0 °C to 50 °C (32 °F to 122 °F) Storage temperature: -30 °C to 80 °C (-22 °F to 176 °F)	
Humidity	20% RH to 95% RH (no condensation)	
General		
Client software	MVS or third-party software meeting with GigE Vision Protocol	
Operating system	32/64-bit Windows 7/10, 64-bit Windows 11, 32/64-bit Linux	
Compatibility	GigE Vision V2.0, GenICam	
Certification	CE, RoHS, KC	