

# MV-CH500-90TM/TC V2

50 MP CMOS 10 GigE Area Scan Camera



GEN<i>CAM

10GiGE  
VISION

## Introduction

MV-CH500-90TM/TC V2 camera adopts GMAX sensor to provide high-quality images with high resolution and low noise. It uses 10 GigE interface to transmit non-compressed data in real time, and its max. frame rate can reach 23.3 fps in full resolution.

## Key Features

- Resolution of 7008 × 7000, pixel size of 3.2 μm × 3.2 μm.
- Supports auto or manual adjustment of white balance, exposure time, and manual adjustment of gain, Gamma correction, LUT, etc.
- Adopts 10 GigE interface, compatible with GigE.
- Compact design with mounting holes on panels for flexible mounting.
- Compatible with GigE Vision V2.0 Protocol, GenICam Standard, and third-party software based on the protocol and standard.

## Available Model

- M58-mount with fan, mono camera: MV-CH500-90TM-M58S-NF V2
- M58-mount with fan, color camera: MV-CH500-90TC-M58S-NF V2
- F-mount with fan, mono camera: MV-CH500-90TM-F-NF V2

## Applicable Industry

PCB AOI, FPD detection, photovoltaics, railway related application, etc.

## Sensor Quantum Efficiency

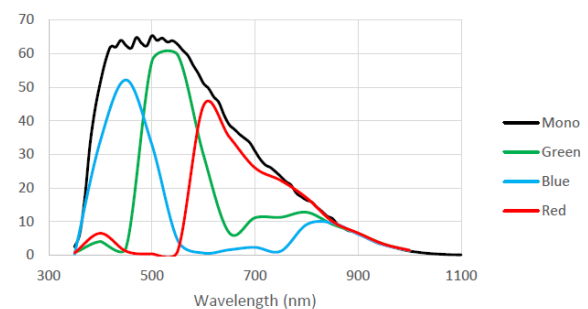

## Specification

Model	MV-CH500-90TM V2	MV-CH500-90TC V2
<b>Performance</b>		
Sensor type	CMOS, global shutter	
Sensor model	Gpixel GMAX	
Pixel size	3.2 $\mu\text{m}$ $\times$ 3.2 $\mu\text{m}$	
Sensor size	22.4 mm $\times$ 22.4 mm	
Resolution	7008 $\times$ 7000	
Max. frame rate	23.3 fps @ 7008 $\times$ 7000 Mono 8	23.3 fps @ 7008 $\times$ 7000 Bayer BG 8
Dynamic range	65 dB	
SNR	40 dB	
Gain	1.25 $\times$ to 6 $\times$	
Exposure time	18 $\mu\text{s}$ to 10 sec	
Exposure mode	Off/Once/Continuous exposure mode	
Mono/Color	Mono	Color
Pixel format	Mono 8/10/10Packed/12/12Packed	Mono 8/10/12, Bayer BG 8/10/10Packed/12/12Packed, YUV422Packed, YUV422_YUYV_Packed, RGB 8, BGR 8
Binning	Supports 1 $\times$ 1, 1 $\times$ 2, 1 $\times$ 4, 2 $\times$ 1, 2 $\times$ 2, 2 $\times$ 4, 4 $\times$ 1, 4 $\times$ 2, 4 $\times$ 4	
Decimation	Supports 1 $\times$ 1, 1 $\times$ 2, 1 $\times$ 4, 2 $\times$ 1, 2 $\times$ 2, 2 $\times$ 4, 4 $\times$ 1, 4 $\times$ 2, 4 $\times$ 4	
Reverse image	Supports horizontal and vertical reverse image output	
<b>Electrical feature</b>		
Data interface	10 Gigabit Ethernet (10000 Mbit/s), compatible with Gigabit Ethernet (1000 Mbit/s)	
Digital I/O	12-pin P10 connector provides power and I/O, including opto-isolated input $\times$ 1 (Line 0), opto-isolated output $\times$ 1 (Line 1), bi-directional non-isolated I/O $\times$ 1 (Line 2), RS-232 $\times$ 1.	
Power supply	9 VDC to 24 VDC	
Power consumption	Typ. 11.8 W @ 12 VDC	Typ. 13.2 W @ 12 VDC
<b>Mechanical</b>		
Lens mount	M58*0.75, flange back length 11.48 mm F-mount, flange back length 46.5 mm	
Dimension	M58-mount with fan: 74 mm $\times$ 74 mm $\times$ 78.8 mm (2.9" $\times$ 2.9" $\times$ 3.1") F-mount with fan: 74 mm $\times$ 74 mm $\times$ 84.8 mm (2.9" $\times$ 2.9" $\times$ 3.3")	
Weight	M58-mount with fan: Approx. 550 g (1.2 lb.) F-mount with fan: Approx. 600 g (1.3 lb.)	
Ingress protection	IP40 (under proper lens installation and wiring)	
Temperature	Working temperature: 0 $^{\circ}\text{C}$ to 50 $^{\circ}\text{C}$ (32 $^{\circ}\text{F}$ to 122 $^{\circ}\text{F}$ ) Storage temperature: -30 $^{\circ}\text{C}$ to 80 $^{\circ}\text{C}$ (-22 $^{\circ}\text{F}$ to 176 $^{\circ}\text{F}$ )	
Humidity	20% RH to 95% RH (no condensation)	
<b>General</b>		
Client software	MVS or third-party software meeting with GigE Vision Protocol	
Operating system	32/64-bit Windows 7/10, 64-bit Windows 11, and 32/64-bit Linux	
Compatibility	GigE Vision V2.0, GenICam	
Certification	CE, RoHS, KC	

## Dimension

**HIKROBOT**

M58-mount with fan:

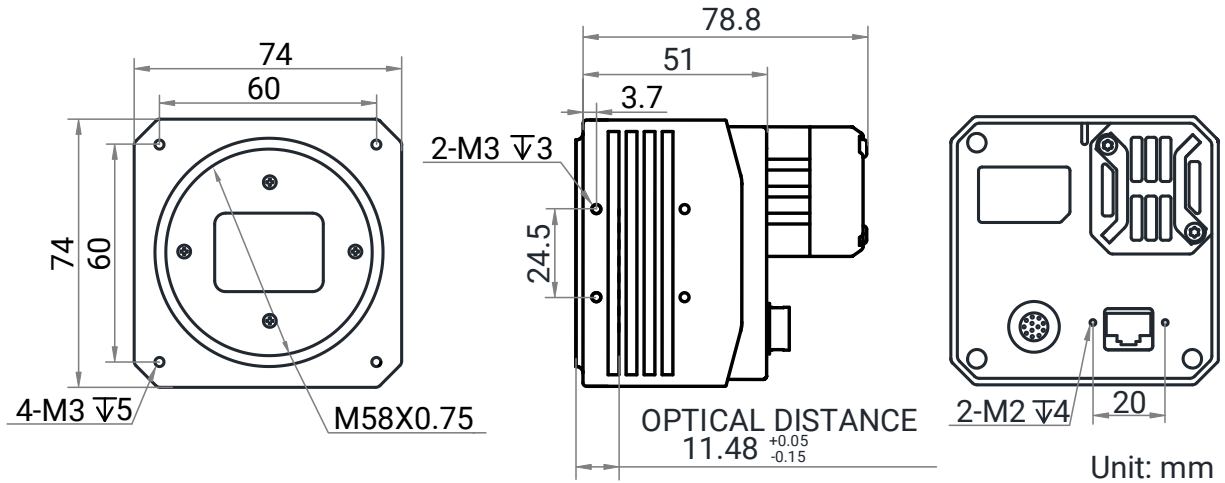

F-mount with fan:

