

MV-CH1510-10(11)XM/XC

151 MP CMOS CoaXPress Area Scan Camera



GEN*i*CAM

Introduction

MV-CH1510-10(11)XM/XC adopts Sony® IMX411 sensor to provide high-quality images. It uses CXP-6 interface to transmit non-compressed images in real time, and its max. frame rate can reach 6.2 fps in full resolution.

Key Feature

- Resolution of 14208 × 10640, pixel size of 3.76 μm × 3.76 μm.
- Adopts rolling shutter CMOS to provide high dynamic range, SNR, and high-quality images.
- Supports the flat field correction.
- Supports TEC mode, and exposure time of up to 10 seconds.
- Supports 16-bit ADC output with high-precision sampling and high dynamic range.
- Adopts CXP-6 interface to transmit data.

Available Model

- Mono camera with fan: MV-CH1510-10XM-M72-NF
- Color camera with fan: MV-CH1510-10XC-M72-NF
- Mono camera with TEC: MV-CH1510-11XM-M72-TF
- Color camera with TEC: MV-CH1510-11XC-M72-TF

Applicable Industry

PCB AOI, FPD, aerial photography, file scan, etc.

Sensor Quantum Efficiency

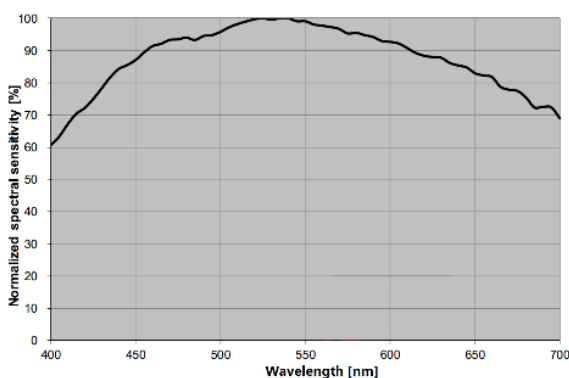

MV-CH1510-10(11)XM

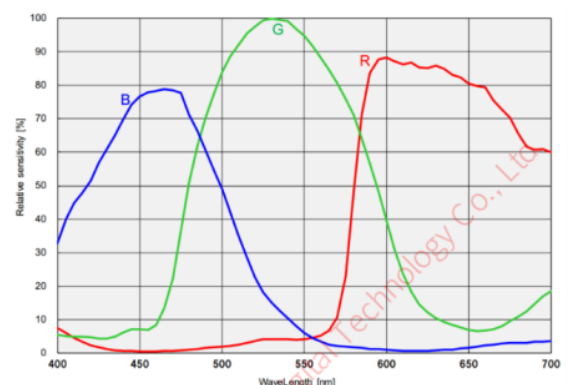

MV-CH1510-10(11)XC

Specification

Model	MV-CH1510-10(11)XM	MV-CH1510-10(11)XC
Camera		
Sensor type	CMOS, rolling shutter	
Sensor model	Sony® IMX411	
Pixel size	3.76 μm × 3.76 μm	
Sensor size	66.7 mm	
Resolution	14208 × 10640	
Max. frame rate	6.2 fps @ 14208 × 10640	
Dynamic range	78.7 dB	
SNR	46.4 dB	
Gain	0 dB to 30 dB	0 dB to 36 dB
Exposure time	15 μs to 10 sec	
Exposure mode	Off/Once/Continuous exposure mode, supports Global Reset, Rolling	
Mono/color	Mono	Color
Pixel format	Mono 8/10/12/16	Mono 8/10/12/16, Bayer RG 8/10/12/16, RGB 8
Binning	Supports 1 × 1, 1 × 2, 1 × 4, 2 × 1, 2 × 2, 2 × 4, 4 × 1, 4 × 2, 4 × 4	
Decimation	Not supported	
Reverse image	Supports horizontal reverse image output	
Electrical feature		
Data interface	CoaXPress with DIN interface	
Digital I/O	12-pin P10 connector provides power and I/O, including opto-isolated input × 1 (Line 0), opto-isolated output × 1 (Line 1), bi-directional non-isolated I/O × 1 (Line 2), and RS-232 × 1	
Power supply	Camera with fan: 12 VDC to 24 VDC Camera with TEC: 24 VDC	
Power consumption	Camera with fan: Typ. 18 W @ 24 VDC Camera with TEC non-cooling: Typ. 21 W @ 24 VDC Camera with TEC cooling: Typ. 55 W @ 24 VDC	Camera with fan: Typ. 21 W @ 24 VDC Camera with TEC non-cooling: Typ. 22 W @ 24 VDC Camera with TEC cooling: Typ. 60 W @ 24 VDC
Mechanical		
Lens mount	M72*0.75, flange back length 19.55 mm	
Dimension	Camera with fan: 100 mm × 100 mm × 74.3 mm (3.9" × 3.9" × 2.9") Camera with TEC: 120 mm × 120 mm × 84.6 mm (4.7" × 4.7" × 3.3")	
Weight	Camera with fan: Approx. 1.0 kg (2.2 lb.) Camera with TEC: Approx. 1.9 kg (4.2 lb.)	
Ingress protection	IP40 (under proper lens installation and wiring)	
Temperature	Working temperature: 0 °C to 50 °C (32 °F to 122 °F) Storage temperature: -30 °C to 70 °C (-22 °F to 158 °F)	
Humidity	20% RH to 95% RH (no condensation)	
General		
Client software	Frame grabber software meeting with CoaXPress Protocol	
Operating system	32/64-bit Windows 7/10, 64-bit Windows 11 with 8 GB memory or above	
Compatibility	CoaXPress, GenICam	
Certification	CE, RoHS, KC	

Dimension

Camera with fan:

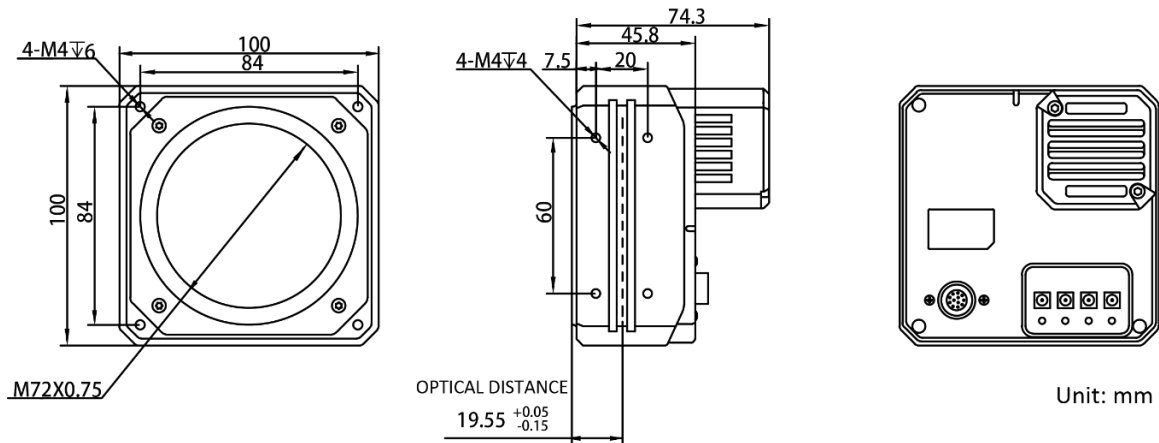

Camera with TEC:

