

MV-CH089-10GM/GC V4

8.9 MP 1" CMOS GigE Area Scan Camera



GEN*i*CAM

GigE
VISION

Introduction

MV-CH089-10GM/GC V4 camera adopts Sony® IMX267 sensor to provide high-quality image. It uses GigE interface to transmit non-compressed images in real time with max. frame rate reaching 13.7 fps.

Key Feature

- Supports LSC, Sequencer, passive transmission, etc.
- Color camera supports Super Bayer, Super Palette, etc.
- Compact design with mounting holes on panels for flexible mounting from 4 sides.
- Adopts GigE interface and max. transmission distance of 100 meters without relay.
- Supports hardware trigger, software trigger, free run, etc.
- Compatible with GigE Vision Protocol V2.0, GenICam Standard, and third-party software based on these protocol and standard.

Dimension

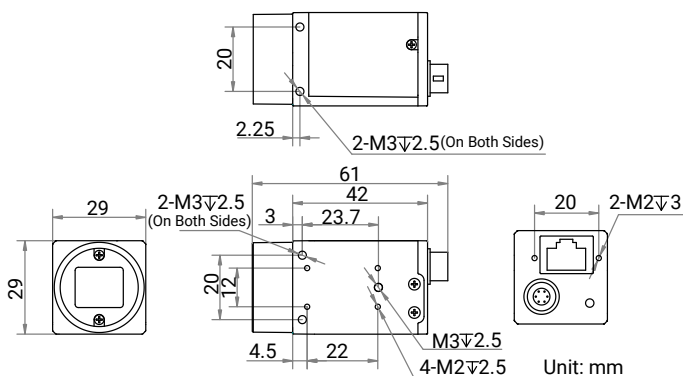

Available Model

- Mono camera: MV-CH089-10GM
- Color camera: MV-CH089-10GC

Applicable Industry

Electronic semiconductor, factory automation, logistics code reading, medicine packaging, etc.

Sensor Quantum Efficiency

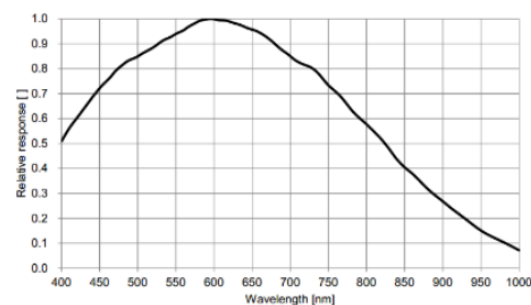

MV-CH089-10GM V4

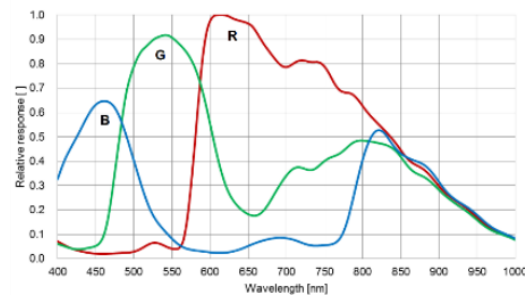

MV-CH089-10GC V4

Specification

Model	MV-CH089-10GM V4	MV-CH089-10GC V4
Performance		
Sensor type	CMOS, global shutter	
Sensor model	Sony® IMX267	
Pixel size	3.45 μm × 3.45 μm	
Sensor size	1"	
Resolution	4096 × 2160	
Max. frame rate	13.7 fps @ 4096 × 2160 Mono 8	13.7 fps @ 4096 × 2160 Bayer RG 8
Dynamic range	70.8 dB	
SNR	39.8 dB	
Gain	0 dB to 24 dB	
Exposure time	UltraShort exposure mode: 1 μs to 14 μs	
	Standard exposure mode: 15 μs to 10 sec	
Exposure mode	Off/Once/Continuous exposure mode	
Mono/color	Mono	Color
Pixel format	Mono 8/10/10Packed/12/12Packed	Mono 8/10/12, Bayer RG 8/10/10Packed/12/12Packed, YUV422Packed, YUV422_YUYV_Packed, RGB 8, BGR 8
Binning	Supports 1 × 1, 2 × 2, 4 × 4	
Decimation	Supports 1 × 1, 2 × 2, 4 × 4	
Reverse image	Supports horizontal and vertical reverse image output	
Electrical features		
Data interface	Gigabit Ethernet (1000 Mbit/s), compatible with Fast Ethernet (100 Mbit/s)	
Digital I/O	6-pin P7 connector provides power and I/O, including opto-isolated input × 1 (Line 0), opto-isolated output × 1 (Line 1), and bi-directional non-isolated I/O × 1 (Line 2).	
Power supply	9 VDC to 24 VDC, supports PoE	
Power consumption	Typ. 2.3 W @ 12 VDC	Typ. 2.4 W @ 12 VDC
Mechanical		
Lens mount	C-mount	
Dimension	29 mm × 29 mm × 42 mm (1.1" × 1.1" × 1.7")	
Weight	Approx. 100 g (0.2 lb.)	
Ingress protection	IP40 (under proper lens installation and wiring)	
Temperature	Working temperature: -10 °C to 50 °C (14 °F to 122 °F)	
	Storage temperature: -30 °C to 80 °C (-22 °F to 176 °F)	
Humidity	20% RH to 95% RH (no condensation)	
General		
Client software	MVS or third-party software meeting with GigE Vision Protocol	
Operating system	32/64-bit Windows 7/10, 64-bit Windows 11, and 32/64-bit Linux	
Compatibility	GigE Vision V2.0, GenICam	
Certification	CE, RoHS, KC	