

MV-CB016-10UM/UC

1.6 MP 1/2.9" CMOS USB3.0 Board Level Camera

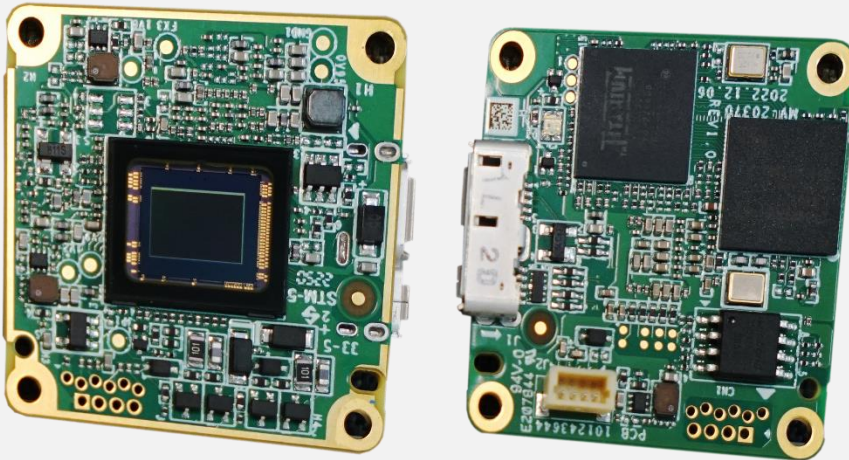

GEN*i*CAM

USBTM
VISION

Introduction

MV-CB016-10UM/UC camera adopts Sony® IMX273 sensor to provide high-quality image. With single board design, it is small in size, which can meet different spatial requirements.

Key Feature

- Supports auto and manual adjustment for gain, exposure control, white balance, LUT, etc.
- Adopts image interpolation algorithm for color camera to have better color correction.
- Power supply and data transmission via USB3.0 interface.
- Compatible with USB3 Vision Protocol, GenICam standard, and the third-party software based on these protocol and standard.

Available Model

- Single board mono camera: MV-CB016-10UM-B
- Single board color camera: MV-CB016-10UC-B
- C-mount mono camera: MV-CB016-10UM-C
- C-mount color camera: MV-CB016-10UC-C
- M12-mount mono camera: MV-CB016-10UM-S
- M12-mount color camera: MV-CB016-10UC-S

Applicable Industry

Electronic semiconductor, factory automation, logistics, liquor and beverage, medicine packing, etc.

Sensor Quantum Efficiency

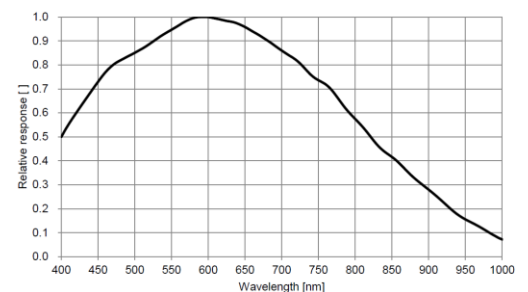

MV-CB016-10UM

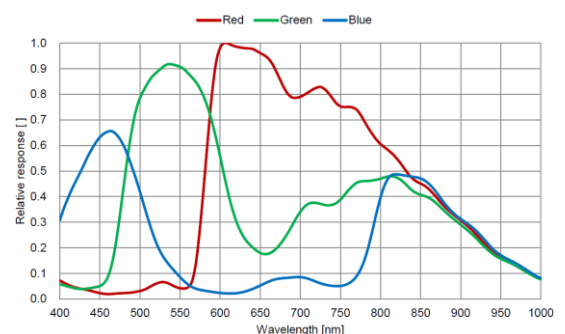

MV-CB016-10UC

Model	MV-CB016-10UM	MV-CB016-10UC
Performance		
Sensor type	CMOS, global shutter	
Sensor model	Sony [®] IMX273	
Pixel size	3.45 μm × 3.45 μm	
Sensor size	1/2.9"	
Resolution	1440 × 1080	
Max. frame rate	165.4 fps @ 1440 × 1080 Mono 8 (ADC 12)	165.4 fps @ 1440 × 1080 Bayer RG 8 (ADC 12)
	249.1 fps @ 1440 × 1080 Mono 8 (ADC 8)	249.1 fps @ 1440 × 1080 Bayer RG 8 (ADC 8)
Dynamic range	71.5 dB	
SNR	39.9 dB	
Gain	0 dB to 17 dB	
Exposure time	UltraShort exposure mode: 1 μs to 14 μs	
	Standard exposure mode: 15 μs to 10 sec	
Exposure mode	Off/ Once/ Continuous exposure mode	
Mono/color	Mono	Color
Pixel format	Mono 8/10/10Packed/12/12Packed	Mono 8/10/12 Bayer RG 8/10/10Packed/12/12Packed, YUV422Packed, YUV422_YUYV_Packed, RGB 8, BGR 8
Binning	Supports 1 × 1, 2 × 2	
Decimation	Supports 1 × 1, 2 × 2	
Reverse image	Supports horizontal and vertical reverse image output	
Electrical feature		
Data interface	USB 3.0	
Digital I/O	Bi-directional non-isolated I/O × 2 (Line 2, Line 5)	
Power supply	USB 3.0 power supply	
Power consumption	Typ. 1.5 W @ 5 VDC	Typ. 1.9 W @ 5 VDC
Mechanical		
Lens mount	Single board camera: None C-mount camera: C-mount M12-mount camera: M12-mount	
Dimension (without lens)	Single board camera: 32.5 mm × 32.5 mm × 1.6 mm (1.3" × 1.3" × 0.1") C-mount camera: 35 mm × 35 mm × 8.6 mm (1.4" × 1.4" × 0.3") M12-mount camera: 35 mm × 35 mm × 8.6 mm (1.4" × 1.4" × 0.3")	
Weight	Single board camera: Approx. 10 g (0.02 lb.) C-mount camera: Approx. 30 g (0.07 lb.) M12-mount camera: Approx. 43.5 g (0.1 lb.)	
Temperature	Working temperature: 0 °C to 50 °C (32 °F to 122 °F) Storage temperature: -30 °C to 70 °C (-22 °F to 158 °F)	
Humidity	20% RH to 80% RH (no condensation)	
General		
Client software	MVS or third-party software with USB3 Vision Protocol	
Operating system	32/64-bit Windows 7/10, 64-bit Windows 11, and 32/64-bit Linux	
Compatibility	USB3 Vision, GenICam	
Certification	CE, RoHS, KC	

Dimension

Single board camera:

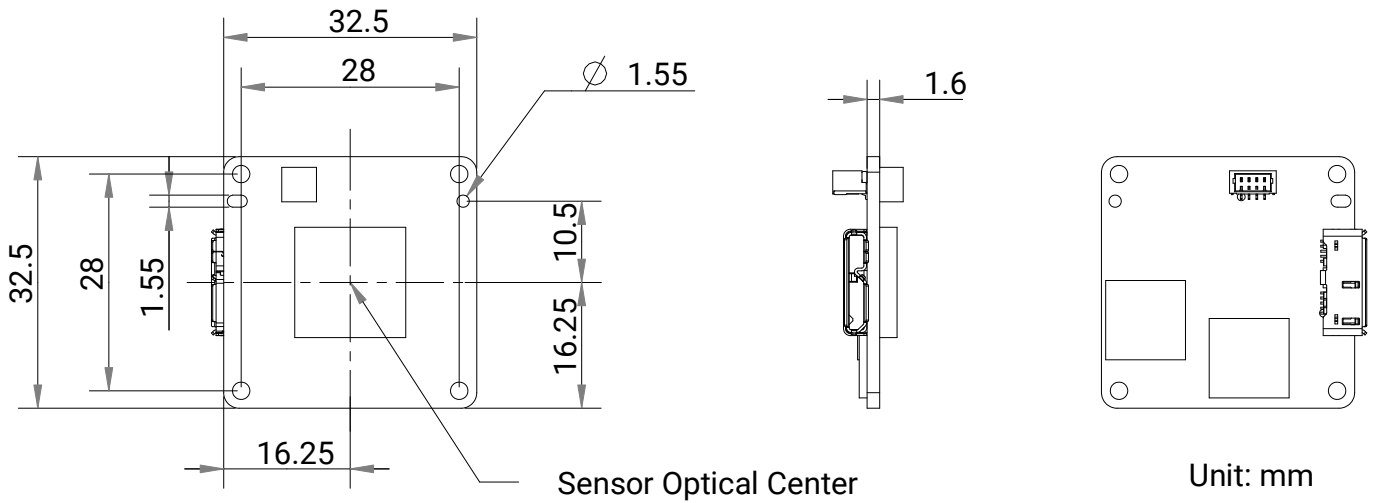

C-mount camera:

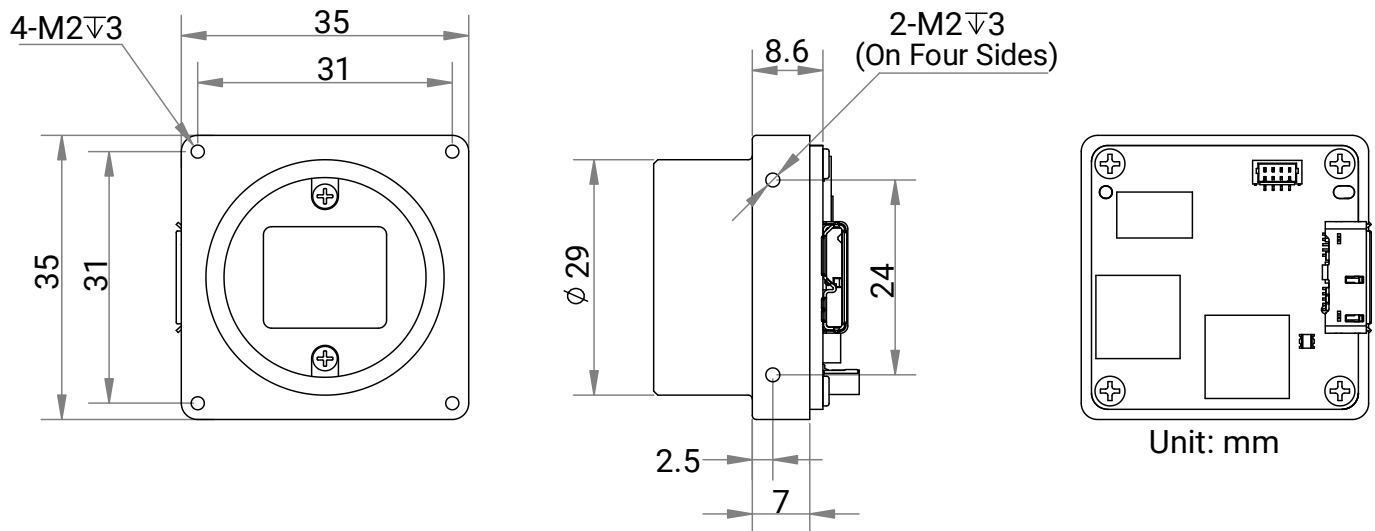

M12-mount camera:

